

## **TEST REPORT FIRES-FR-044-21-AUNE**

---

**Single leaf timber flush door with timber frame, type Vline Secure 30**

This is an electronic version of the test report, which is equivalent to the printed version. The electronic version is always issued, the printed version is issued only at the request of the sponsor. The document does not contain visual signatures of the responsible persons. The validity of the document is conditional upon a valid certified digital seal. The original file containing this document can be downloaded from the secure cloud FIRES, s.r.o., after getting the link from the sponsor. Any information listed in this document is the property of the sponsor and shall not be used or published without written permission. This file may only be modified by the editor i.e. Testing laboratory FIRES, s.r.o. Sponsor is allowed to publish this document in parts only with written permission of the editor.

## TEST REPORT

### FIRES-FR-044-21-AUNE

**Tested property:** Fire resistance  
**Test method:** EN 1634-1:2014+A1:2018  
**Test type:** Accredited  
**Date of issue:** 09. 04. 2021

**Name of the product:** Single leaf timber flush door with timber frame, type Vline Secure 30

**Manufacturer:** RAM Extrusion Limited, Unit 203, Stonebridge Cross Business Park, Pointon Way, Droitwich Spa, WR9 0LW, UK  
**Sponsor:** RAM Extrusion Limited, Unit 203, Stonebridge Cross Business Park, Pointon Way, Droitwich Spa, WR9 0LW, UK

**Test carried out by:** FIRES, s.r.o., Testing laboratory  
**Task No.:** PR-20-0413  
**Specimens received:** 01. 03. 2021  
**Date of the test:** 09. 03. 2021

**Technician responsible for the technical side of this report:** Bc. Matúš Korenko

Number of pages: 51  
Test reports: 4

Copy No.: 2

#### Distribution list:

Copy No. 1 FIRES, s. r. o., Osloboditeľov 282, 059 35 Batizovce, Slovak Republic  
Copy No. 2 RAM Extrusion Limited, Unit 203, Stonebridge Cross Business Park, Pointon Way, Droitwich Spa, WR9 0LW, UK  
Copy No. 3 Exitex Ltd, Mountpleasant, Dundalk, Louth A91HK29, Ireland  
Copy No. 4 Intext Ltd, Mladost 4, Building Lilia, bl. 485, Floor 1, Shop 1, Bulgaria

This report includes accreditation mark SNAS with additional mark ILAC-MRA. SNAS is signatory of ILAC-MRA, Mutual recognition agreement (of accreditation), which is focused on promoting of international acceptance of accredited laboratory data and reducing technical barriers to trade, such as the retesting of products on markets of signatories. More information about ILAC-MRA is on [www.ilac.org](http://www.ilac.org). Signatories of ILAC-MRA are e.g. SNAS (Slovakia), CAI (Czech Republic), PCA (Poland), DakKS (Germany) or BMWA (Austria). Up to date list of ILAC-MRA signatories is on <http://ilac.org/ilac-mra-and-signatories/>. FIRES, s.r.o. Batizovce is full member of EGOLF also, more information [www.egolf.org.uk](http://www.egolf.org.uk). Test reports issued by FIRES, s.r.o. are valid in United Arab Emirates based on list of laboratories approved by United Arab Emirates Ministry of Interior Civil Defence (up-to-date list is available on: [www.dcd.gov.ae/eng/](http://www.dcd.gov.ae/eng/)) and are valid in Qatar based on list of laboratories approved by Ministry of Interior General Directorate Civil Defence of Qatar (up-to-date list is available on: <https://fires.sk/wp-content/themes/fires/img/files/QATAR.pdf>).



## 1. INTRODUCTION

This test report contains the results of a test carried out by FIRES, s.r.o., Osloboditeľov 282, Batizovce, Testing laboratory accredited for testing by SNAS. Certificate of accreditation No.: S-159. The purpose of the test was to gain information for product classification.

Sponsor's representatives witnessing the test:

Ing. Juraj Akuratný                      AKURATNY FIRE CONSULTING, s.r.o.

test carried out by                      Bc. Matúš Korenko  
operator                                      Ing. Marek Gorlický

## 2. MEASURING EQUIPMENT

Identification number	Measuring equipment	Note
F 90 001	Vertical test furnace for fire resistance testing	-
F 69 010	PLC system for data acquisition and control TECOMAT TC 700	-
F 40 019	Visual and calculating software to PLC TECOMAT TC 700	-
F 40 017	Control and communication software to PLC TECOMAT TC 700	-
F 40 018	SW Reliance	-
F 40 020	Driver Tecomat - Reliance (SW)	-
F 71 041, F 71 042	Transducer of differential pressure (-50 to + 150) Pa	pressure inside the test furnace
F 54 078	Digital calliper (0 to 150) mm	-
F 54 043	Racking meter	-
F 53 004	Suspension load-cell scale	finding out of humidity equilibrium state
F 69 009	PLC system for data acquisition and climate control TECOMAT TC 604	-
F 60 001 - F 60 009	Sensors of temperature and relative air humidity	climatic conditions measuring
F 18 501 - F 18 508	Plate thermometers	temperature inside the test furnace, according to EN 1363-1
F 18 002 - F 18 200	Unsheathed thermocouples type K 2 x Ø 0,5 mm	temperatures on the unexposed surface of the specimens
F 18 701	Sheathed thermocouple type K Ø 3 mm	ambient temperature
F 18 001	Roving thermocouple	-
F 74 007 - F 74 014	Cable position transducers (0 to 1250) mm	measuring of deflection
F 54 024	Ruler for measuring of deflection (by laser)	measuring of deflection
F 90 005	Gap gauge for fire resistance testing Ø 25 mm	-
F 90 006	Gap gauge for fire resistance testing Ø 6 mm	-
F 90 007	Frame for supporting the cotton pad (100 x 100) mm for fire resistance tests	-
F 57 005	Digital stop-watch	-



### 3. PREPARATION OF THE SPECIMENS

Testing laboratory noted down production data of the specimens from a certified production. Test specimen data are listed in following table:

Place of production	Intext Ltd, 4400 Pazardjik, Glavinitza district Industrial zone, Bulgaria
Production number	Specimen No. 1: 60498_1_2-02 (V 39 261) Specimen No. 2: 60498_1_2-01 (V 39 260)
Date of production	12/2020
Check-out date	04. 01. 2021
Number of certificate ISO 9001	031212
Issuing Body	Intertek Certification Limited, UK
Date of issuing	15. 04. 2019

Certification body has carried out specimens sampling. Sampling data are specified in Sampling report No.: FIRES-SR-010-21.

Specimens were delivered to the testing laboratory in assembled state by the test sponsor. Installation of the specimens to the supporting construction was carried out by workers of the sponsor.

### 4. PREPARATION OF THE TEST

#### 4.1 DESCRIPTION OF THE SPECIMENS STRUCTURE

Two specimens of Single leaf timber flush door with timber frame, type Vline Secure 30 were used for fire resistance test.



#### Dimensions

Overall dimensions of door frame:	(996 x 2 081) mm (width x height)
Overall dimensions of door leaf:	(926 x 2 040 x 52) mm (width x height x thickness)
Clear opening of door frame:	(908 x 2 037) mm (width x height)
Weight of door leaf: (measured in the testing laboratory)	Specimen No. 1: 63,25 kg Specimen No. 2: 63,20 kg



**DOOR FRAME**

Door frame (door frame jambs and door frame head) is made of Sapele wood (entandrophragma cylindricum wood) profiles (44 x 80) mm (supplier: JAF Bulgaria), bulk density 640 kg.m<sup>-3</sup> with milled grooves (15 x 4) mm in two rows for intumescent tapes. Door frame jambs and door frame head are joined together with butt joint, fixed by means of screws (Ø 4 x 60) mm and with wood glue, type SOUDAL 67A D3 (manufacturer: SOUDAL NV, Belgium).

Dimension of door frame rebate is (54 x 12) mm (depth x width).

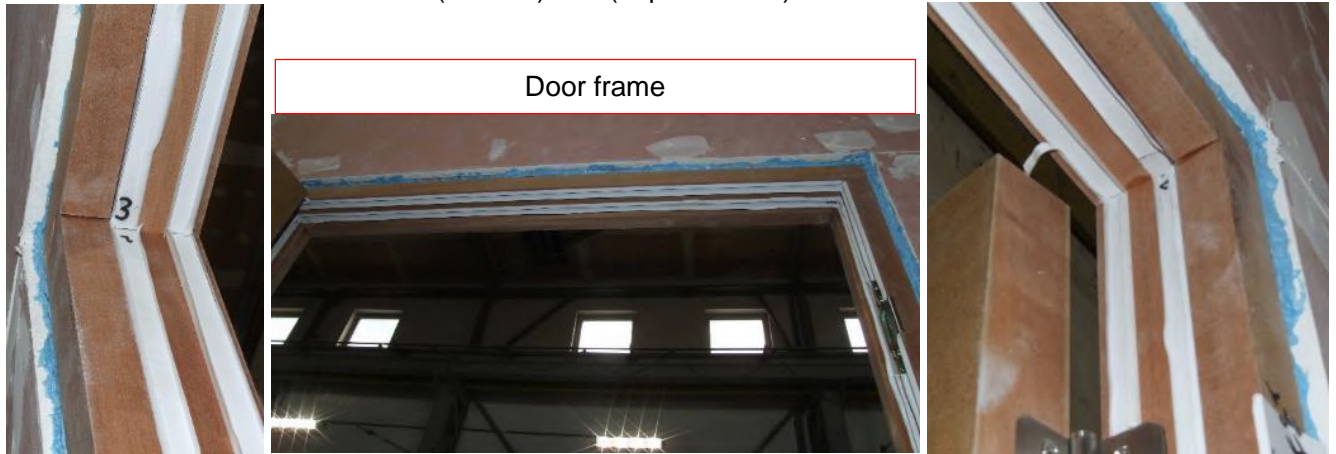

Joint of the individual parts of door frame

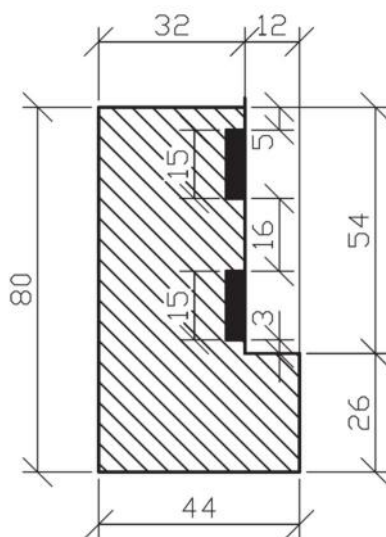
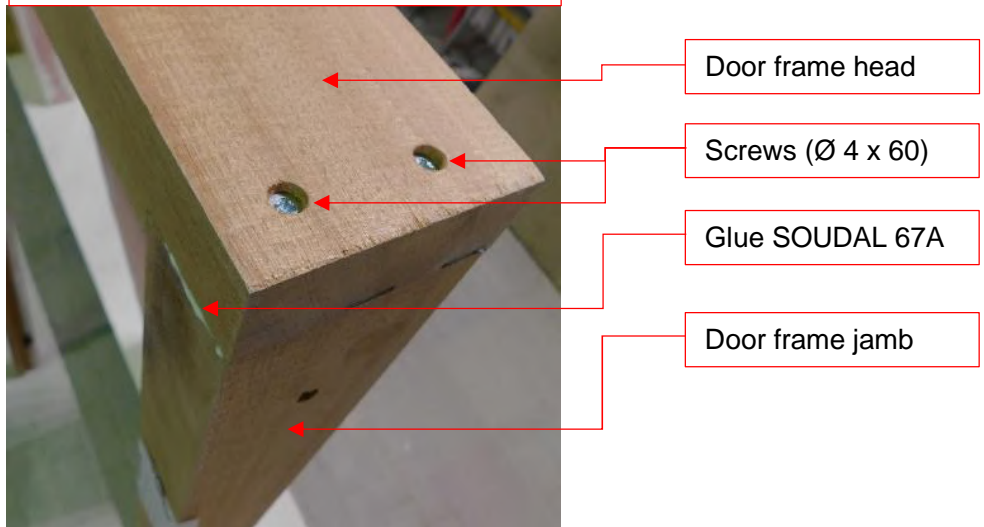





**DOOR LEAF**

The frame of door leaf is made of Sapele wood (*entandrophragma cylindricum* wood) profiles (45 x 44) mm (width x thickness) (supplier: JAF Bulgaria), bulk density 640 kg.m<sup>-3</sup>. Individual profiles are jointed together by means of PVAc glue ORGALOK MA 35, mass 1 g.cm<sup>-2</sup> (manufacturer: ORGANIK KIMYA SANAYI VE TICARET A.S.) and steel staples (14 x 13 x 9) mm in max spacing of 500 mm. Corners are butt jointed and fixed with the steel staples.

**Core of the door leaf**

One-piece of chipboard with thickness of 44 mm, with bulk density 600 kg.m<sup>-3</sup> (supplier: UNILIN, division panels, Belgium). Overall dimensions of chipboard are (1950 x 836) mm. Construction of door leaf incl. core of door leaf is covered with one layer of HDF board, 4 mm thick with bulk density 700 kg.m<sup>-3</sup> (supplier: Pflleiderer Polska Sp z o.o.) from both door faces. The HDF boards are glued to the construction of door leaf with PVAc glue ORGALOK MA 35, mass 1 g.cm<sup>-2</sup> (manufacturer: ORGANIK KIMYA SANAYI VE TICARET A.S.).

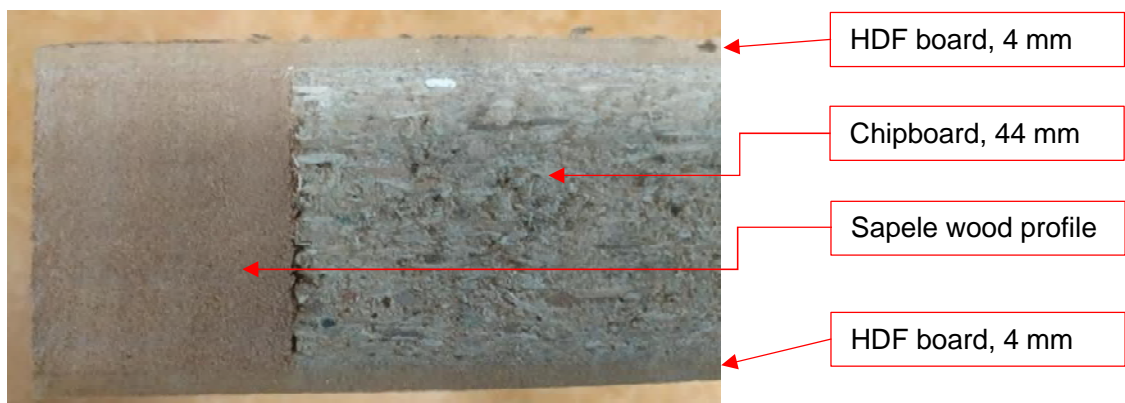

**INTUMESCENT TAPE**

Intumescent tape, type Pyrosist 9010 (15 x 4) mm (manufacturer: RAM Extrusion Ltd) is placed in two rows around the perimeter of door frame in milled groove (15 x 4) mm.



Intumescent graphite pads, type Pyro Hinge Pad, 1 mm thick (manufacturer: RAM Extrusion Ltd.) are placed behind the hinges.





Intumescent graphite lock kit, type Pyrosist Ironmongery Protection, 1 mm thick (manufacturer: RAM Extrusion Ltd.) is placed on the mortise lock.



**HINGES**

3 pieces of hinges, type BRI – 3 CE (manufacturer: Herrayma) fixed to the door leaf and door frame by means of steel screws (Ø 4 x 40) mm. Behind the hinges in joint of sapele profiles (on door frame and door leaf frame) with hinges is placed graphite pads, 1 mm thick (manufacturer: RAM Extrusion Ltd.).

Position of hinges (to the center of hinge):

- 200 mm from the bottom edge of door leaf;
- 1020 mm from the bottom edge of door leaf;
- 200 mm from the upper edge of door leaf.



**LOCK**

Three-point mortise lock, type G-U Secury Automatic VdS, Class A with steel strike plates (manufacturer: Gretsch-Unitas GmbH) operated by stainless steel door handles, order code: DCYVE-SN-DEV (supplier: Darcel) and cylindrical door lock insert, type KINETICA (manufacturer: UAP Limited, UK). Handle is placed 1000 mm and cylindrical insert is placed 900 mm from the bottom edge of door leaf. Lock is fixed to the door leaf by means of steel screws.

Position of latches (to the center of latch):

- bottom latch: 205 mm from the bottom edge of door leaf;
- central latch: 1025 mm from the bottom edge of door leaf;
- top latch: 235 mm from the top edge of door leaf.







**DOOR VIEWER**

Door viewer, type EX 114, Ø 14 mm (supplier: Exitex Ltd., Ireland) is placed in the mid-width of door leaf and 1400 mm from the bottom edge of door leaf. The door viewer body is insulated (wrapped) around the viewer with strip of intumescent tape, type RAM Intumescent Paper, 1 mm thick (manufacturer: RAM Extrusion Ltd.).



**LETTER PLATE**

The door leaf is equipped by letter plate, type The Soterian TS008 white (supplier: UAP Limited, UK) with dimensions (305 x 75) mm fixed in formed opening (206 x 53) mm (width x height) in door leaf by means of steel screws (Ø 5 x 52) mm. The letter plate is placed 660 mm from the bottom edge of door leaf to the bottom edge of letter plate and in the mid-width of door leaf.







### DROP DOWN SEAL

Automatic drop down seal, type Exisound Concealex A8100 (manufacturer: Exitex Ltd., Ireland) is put into the milled groove (20 x 12,5) mm and fixed by screws to the bottom edge of door leaf frame.



### ADDITIONAL DOOR EQUIPMENT

#### Door numerals

The door leaf is equipped by decorative self-adhesive stainless-steel front door numerals (supplier: UAP Limited, UK) placed in mid-width and 210 mm from the top edge of door leaf to the bottom edge of front door numerals.



#### Door data systems tag

The door leaf is also equipped by informative pin, type door data systems tag (manufacturer: DOOR DATA SYSTEMS, UK) placed at the hinges side of door leaf and 1500 mm from the bottom edge of door leaf. *(more detailed information about the door data systems tag is shown in the drawings)*

More detailed information about the construction of the specimens is shown in the drawings which are a part of this test report. Drawings were delivered by the sponsor.

All the information about technical specifications of used materials and semi-products, information about their type sign were delivered by sponsor. This information was not subject to the specimen verification. Parameters which were verified are quoted in paragraph 4.3.



## 4.2 DESCRIPTION OF THE SPECIMENS FIXATION

The test specimens are fixed to the flexible supporting construction 100 mm thick according to EN 1363-1: 2020, Group A for the intended fire resistance EI 60 minutes (Steel profiles CW 50 (50 x 50 x 0,6) mm and UW 50 (50 x 40 x 0,6) mm, covered by two layers of gypsum boards type F 12,5 mm thick on each wall face (manufacturer: Knauf), insulated by mineral wool, 50 mm thick with bulk density 50 kg.m<sup>-3</sup> (manufacturer: Rockwool). Both vertical edges of supporting construction are not fixed to the test frames – free edges, insulated by mineral wool 40 mm – 50 mm thick with bulk density 100 kg.m<sup>-3</sup>.

Steel profiles CW 50 next to the door frame are reinforced with spruce profiles (43 x 45) mm, with bulk density 420 kg.m<sup>-3</sup>.

Frames of the specimens are fixed to the supporting construction by means of steel screws (∅ 7,5 x 112) mm.

Number of fixation points and their location are shown in the drawings.

Gaps (10 mm wide) between the frames of specimens and supporting construction are filled with fire resistance PU foam Blue 60 (manufacturer: BLUE 60 UK Limited).

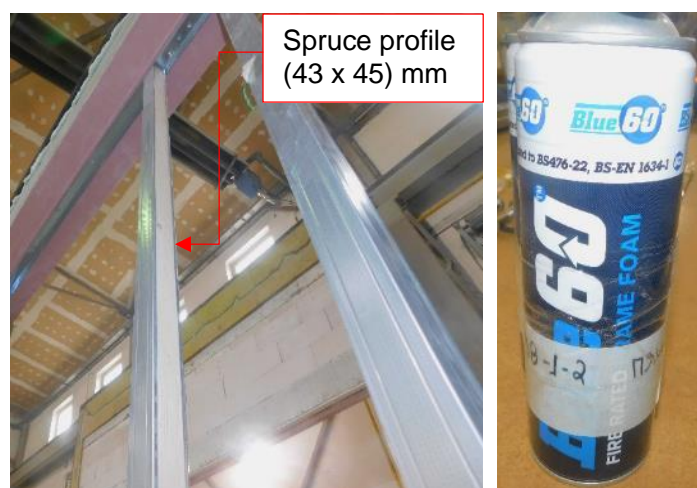

Supporting construction, its thickness, orientation of the specimens and type of specimens' fixing to the supporting construction was chosen by the sponsor of the test.

### Orientation of the specimens during the test

specimen No. 1	Hinges of door leaf placed on the exposed face of the specimen (opening towards the test furnace)
specimen No. 2	Hinges of door leaf placed on the unexposed face of the specimen (opening out of the test furnace)

## 4.3 VERIFICATION OF THE SPECIMENS

The conformity of the drawings and the test specimens was verified before and after the fire resistance test. This verification has been carried out on extra delivered product for this purpose. The specimens corresponded to the drawings which are a part of this test report. The visual review of the test specimens, the used materials as well as the size verification of basic dimensions and the specimens' attachment to the supporting construction were subject to this verification.

## 4.4 CLIMATIC CONDITIONING OF THE SPECIMENS

Test specimens were stored in the hall of the testing laboratory and were conditioned according to EN 1363-1: 2020.

The humidity equilibrium state of test specimens was determined by repetitive balancing of door leaves. The humidity equilibrium state of the test specimens was achieved.



## 4.5 PRE-TEST CONDITIONING OF THE SPECIMENS

The test specimens were submitted to mechanical testing according EN 16034 Annex A before fire resistance test.

Operability test according EN 16034 A.2.2: 25 cycles (opening from fully closed position to maximum possible opening position and closing back to fully closed position).

Gaps measurement: measured gaps around the perimeter of the door leaves are stated on 27<sup>th</sup> page of the test report.

The retention force according to EN 1634-1 cl. 10.1.3 was not measured. The door leaves without automatic closing mechanism.

Final setting according EN 1634-1 cl. 10.1.4 opening to 300 mm and closing manually by the hand. Door leaves without closing mechanism during the test. Door leaves were locked in closed position during the test. Keys were not left in the locks during the test.

## 5. CARRYING OUT OF THE TEST

### 5.1 CONDITIONS OF THE TEST

Conditions during the test in the test furnace (temperature – standard temperature/time curve, pressure, O<sub>2</sub> content) as well as in the testing room (ambient temperature) corresponded to EN 1363-1. Detailed information is a part of this test report, or can be found in the test record.

Values characterizing the testing room environment directly before the test:

Date of the test	Ambient air temperature [°C]
09. 03. 2021	16,8

### 5.2 RESULTS OF THE TEST

Measured values are stated in this test report. Description of the specimens' behavior during the test:

#### Specimen No. 1

Time [min:s]	Face of specimen	Observation
01:00	NS	Smoke release at the hinges side in part of top hinge;
12:00	NS	Smoke release at the lock edge in top part of door leaf;
13:00	NS	Smoke release around the letter plate;
15:00	NS	Intensive smoke release from the letter plate; Darkening of the door leaf surface in placed of smoke release around the letter plate; No further significant changes are visible;
20:30	NS	Smoke release from both top corners of door leaf;
30:00	NS	Darkening of the door leaf surface in placed of smoke release; No further significant changes are visible;
36:00	NS	No further significant changes are visible;
42:00	NS	Flashing flames under the letter plate during approx. 2s.





Time [min:s]	Face of specimen	Observation
43:50	NS	Sustained flaming in placed of the letter plate – <b>integrity failure</b> ; 
44:20	NS	Sealant applicated in placed of flaming (above the letter plate);
45:00	NS	Sealant applicated around the letter plate;
46:50	NS	Letter plate filled with the mineral wool pieces;
49:00	NS	Sustained flaming at the bottom hinges edge of door leaf;
51:00	NS	Mineral wool pieces and sealant applicated in placed of flaming;
57:00	NS	Sustained flaming at the bottom edge and the top hinges edge of door leaf;
58:30	NS	Sustained flaming around the perimeter of door leaf;
60:30		Termination of the test.

**Specimen No. 2**

Time [min:s]	Face of specimen	Observation
01:30	NS	Smoke release around the top hinge; Smoke release at the top lock edge in placed of top latch;
03:30	NS	Smoke release from the letter plate;
10:30	NS	Persistent smoke release from the top latch;
15:00	NS	Smoke release from the lock (in placed of the central latch); No further significant changes are visible;
20:00	NS	Darkening of the door leaf surface in placed of smoke release;
30:00	NS	No further significant changes are visible;
30:30	NS	Releasing of the thermocouple No. 53 placed on the letter plate;
36:00	NS	No further significant changes are visible;
49:30	NS	Sustained flaming on the vertcial edge of letter plate – <b>integrity failure</b> ; 
50:20	NS	Sustained flaming at the bottom edge of door leaf;
52:00	NS	Mineral wool pieces and sealant applicated in placed of flaming;
57:00	NS	Sustained flaming at the bottom edge of door leaf;
60:30		Termination of the test.

ES exposed face of specimen  
 NS unexposed face of specimen



## 6. CLOSING

### Evaluation of the test:

#### SPECIMEN No. 1:

Performance criterion	Time till the performance criterion is achieved
integrity – sustained flaming	43 minutes
integrity – gap gauges Ø 6 mm and Ø 25 mm	43 minutes no failure
integrity – cotton pad	43 minutes
insulation – average temperature (140 K)	43 minutes no failure
insulation – maximal temperature (180 K)	43 minutes no failure
insulation – maximal temperature (supplementary procedure) (180 K)	43 minutes no failure
insulation – maximal temperature (door frame) (180 K / 360 K)	43 minutes / 43 minutes no failure
radiation 15 kW.m <sup>-2</sup>	43 minutes no failure

#### SPECIMEN No. 2:

Performance criterion	Time till the performance criterion is achieved
integrity – sustained flaming	49 minutes
integrity – gap gauges Ø 6 mm and Ø 25 mm	49 minutes no failure
integrity – cotton pad	49 minutes
insulation – average temperature (140 K)	49 minutes no failure
insulation – maximal temperature (180 K)	49 minutes no failure
insulation – maximal temperature (supplementary procedure) (180 K)	49 minutes no failure
insulation – maximal temperature (door frame) (180 K / 360 K)	49 minutes / 49 minutes no failure
radiation 15 kW.m <sup>-2</sup>	49 minutes no failure

The fire test was terminated in the 61<sup>st</sup> minute. The test continued after the specimen No.1 integrity failure in the 44<sup>th</sup> minute and the specimen No. 2 integrity failure in the 50<sup>th</sup> minute at the request of test sponsor.

The performance criteria of insulation are automatically assumed not to be satisfied when the criterion of integrity ceases to be satisfied (acc. to clause 11.4.2 of EN 1363-1).

Regarding to low average temperatures on unexposed specimen surface below 300°C the performance criteria of radiation is to be complied as satisfied.

## 7. DIRECT APPLICATION OF TEST RESULTS

Direct field of application is valid in accordance with clause 13 of EN 1634-1:2014+A1:2018. Validity of individual items of field of direct application shall be determined in the classification process.



**Measured values inside the test furnace**

Time t [min]	Temperature [°C]											Deviation	Pressure [Pa]	
	Td1	Td2	Td3	Td4	Td5	Td6	Td7	Td8	Tave	Tn	To	d <sub>e</sub> [%]	p1	p2
0	18,4	19,2	20,0	20,4	19,5	19,4	20,0	20,3	19,7	20,0	16,8			
5	567,1	549,6	551,7	525,6	584,0	574,6	561,3	536,0	556,2	576,0	17,1	-3,9	17,8	0,8
10	705,4	694,8	682,9	709,1	699,7	673,9	661,3	634,7	682,7	678,0	16,5	-1,3	17,2	0,0
15	750,8	771,3	765,3	758,3	734,7	721,6	754,0	755,1	751,4	739,0	14,2	-0,7	18,0	0,7
20	761,5	786,7	795,0	794,1	744,4	730,8	785,2	802,6	775,0	781,0	13,4	-0,8	18,2	0,5
25	812,2	814,3	808,6	813,5	812,8	801,3	791,1	778,6	804,1	815,0	13,6	-0,6	18,6	0,1
26	819,7	830,3	828,7	828,2	808,6	797,2	809,5	812,0	816,8	820,0	13,6	-0,6	18,8	0,1
27	830,1	837,6	833,0	837,9	822,0	810,6	814,1	814,7	825,0	826,0	13,6	-0,6	18,9	0,4
28	832,1	841,3	835,1	839,7	825,7	813,4	815,3	815,8	827,3	832,0	13,4	-0,6	19,0	0,5
29	828,9	836,9	831,3	838,5	822,4	811,2	812,4	814,7	824,5	837,0	13,6	-0,6	19,0	0,9
30	824,9	831,8	828,1	834,4	818,9	808,2	810,5	807,6	820,6	842,0	13,4	-0,7	18,8	0,5
31	825,9	834,1	833,9	851,9	818,0	808,0	817,9	822,1	826,5	847,0	13,3	-0,7	18,6	0,5
32	863,9	874,3	877,9	896,8	856,8	845,4	857,6	861,4	866,8	851,0	13,2	-0,6	18,8	0,7
33	856,0	860,4	864,5	886,4	855,0	845,6	841,8	837,9	856,0	856,0	13,4	-0,6	18,6	0,8
34	850,0	854,6	859,2	881,1	849,3	839,8	834,0	828,8	849,6	860,0	13,3	-0,6	18,8	0,9
35	842,1	847,3	852,2	873,8	841,4	833,4	828,4	822,1	842,6	865,0	13,4	-0,7	19,0	1,0
36	850,2	855,1	861,4	880,9	848,4	840,2	835,4	831,0	850,3	869,0	13,4	-0,8	19,1	0,7
37	849,8	855,8	863,4	884,1	847,2	839,9	836,6	832,3	851,1	873,0	13,4	-0,8	19,1	0,6
38	863,8	875,9	887,2	898,9	856,3	852,4	859,7	854,2	868,6	877,0	13,6	-0,8	19,3	0,6
39	862,3	873,6	885,0	896,1	854,8	853,1	859,8	851,8	867,1	881,0	13,6	-0,8	19,0	1,0
40	875,8	886,1	897,2	909,4	870,9	869,3	875,7	863,5	881,0	885,0	13,5	-0,8	18,9	0,9
41	888,5	898,1	906,4	916,1	886,0	884,5	885,7	872,5	892,2	888,0	13,5	-0,8	19,2	1,2
42	884,6	893,1	899,3	907,0	884,6	881,7	885,3	866,4	887,8	892,0	13,4	-0,8	19,1	0,6
43	880,9	889,5	895,9	903,4	880,1	878,7	882,1	862,3	884,1	896,0	13,2	-0,8	18,8	0,7
44	877,3	885,2	892,6	900,3	877,5	874,6	879,4	859,8	880,8	899,0	13,4	-0,8	18,6	0,9
45	884,4	894,5	903,2	911,6	881,7	879,1	883,6	870,5	888,6	902,0	13,3	-0,8	18,7	1,0
46	889,9	900,0	907,6	915,7	887,3	884,6	888,0	876,9	893,8	906,0	13,5	-0,9	19,0	0,8
47	893,4	903,7	911,9	920,8	890,9	889,2	892,8	879,2	897,7	909,0	13,6	-0,9	19,1	1,0
48	899,2	908,5	916,7	926,4	897,3	894,5	898,0	883,8	903,1	912,0	13,5	-0,9	19,0	0,7
49	900,2	909,7	918,2	926,0	898,3	895,3	898,6	885,0	903,9	915,0	13,4	-0,9	19,1	0,4
50	903,1	912,5	920,7	929,6	900,4	897,8	900,1	888,7	906,6	918,0	13,4	-0,9	19,3	0,4
51	906,0	915,2	923,2	933,1	904,3	901,5	905,4	888,9	909,7	921,0	13,4	-0,9	19,2	0,6
52	909,2	918,4	926,6	935,7	906,5	903,6	906,1	893,3	912,4	924,0	13,5	-0,9	19,0	0,8
53	911,3	919,9	928,2	937,0	908,1	905,9	910,1	896,2	914,6	927,0	13,4	-0,9	19,0	1,0
54	924,1	934,2	943,9	954,5	919,1	916,8	920,3	914,1	928,4	930,0	13,3	-0,9	18,9	1,3
55	939,0	947,0	954,0	965,0	935,0	931,6	934,7	925,2	941,4	932,0	13,4	-0,9	19,1	1,4
56	941,1	948,6	955,3	968,2	937,1	933,3	934,5	925,4	942,9	935,0	13,3	-0,8	19,1	1,2
57	950,4	958,2	964,3	982,1	945,4	942,2	943,4	935,1	952,6	938,0	13,4	-0,8	19,2	1,3
58	939,7	943,7	947,9	956,8	938,7	936,5	934,2	916,6	939,3	940,0	13,3	-0,8	19,1	1,0
59	942,6	947,5	951,3	957,0	944,3	941,5	939,2	917,2	942,6	943,0	13,2	-0,7	19,0	1,1
60	934,4	940,4	942,8	945,4	942,3	941,3	950,6	923,1	940,0	945,0	13,6	-0,7	18,2	0,4

- Tave** Average temperature in the test furnace calculated from individual thermometers
- Tn** Standard temperature in the test furnace laid down according to test guideline
- d<sub>e</sub>** Deviation of the average temperature from the standard temperature calc. acc. to test guideline
- To** Ambient temperature
- p1** Pressure inside the test furnace measured under the ceiling of test furnace
- p2** Pressure inside the test furnace at the height of neutral pressure level 500 mm above test furnace floor

Layout of measuring points in the test furnace:

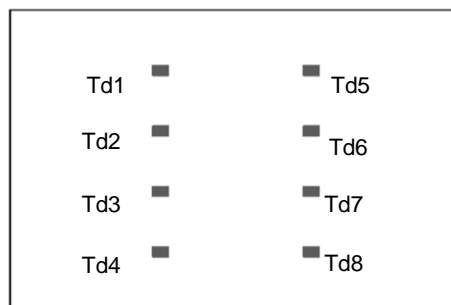





Measured values inside the test furnace / graph

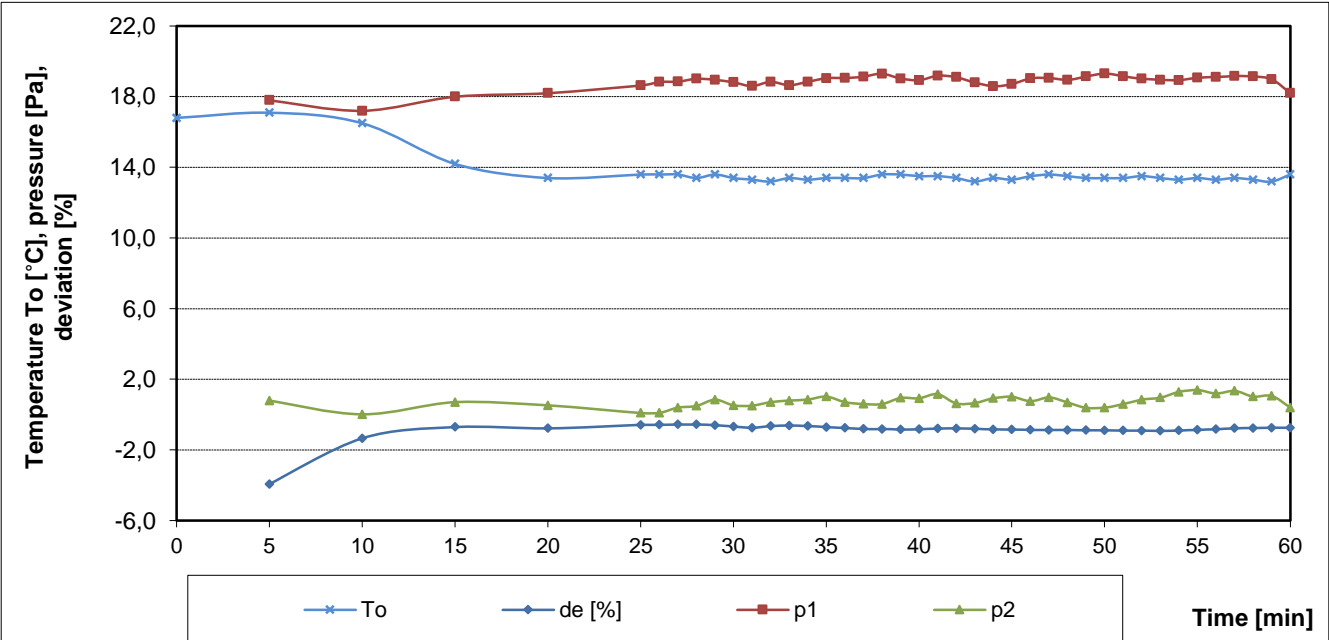
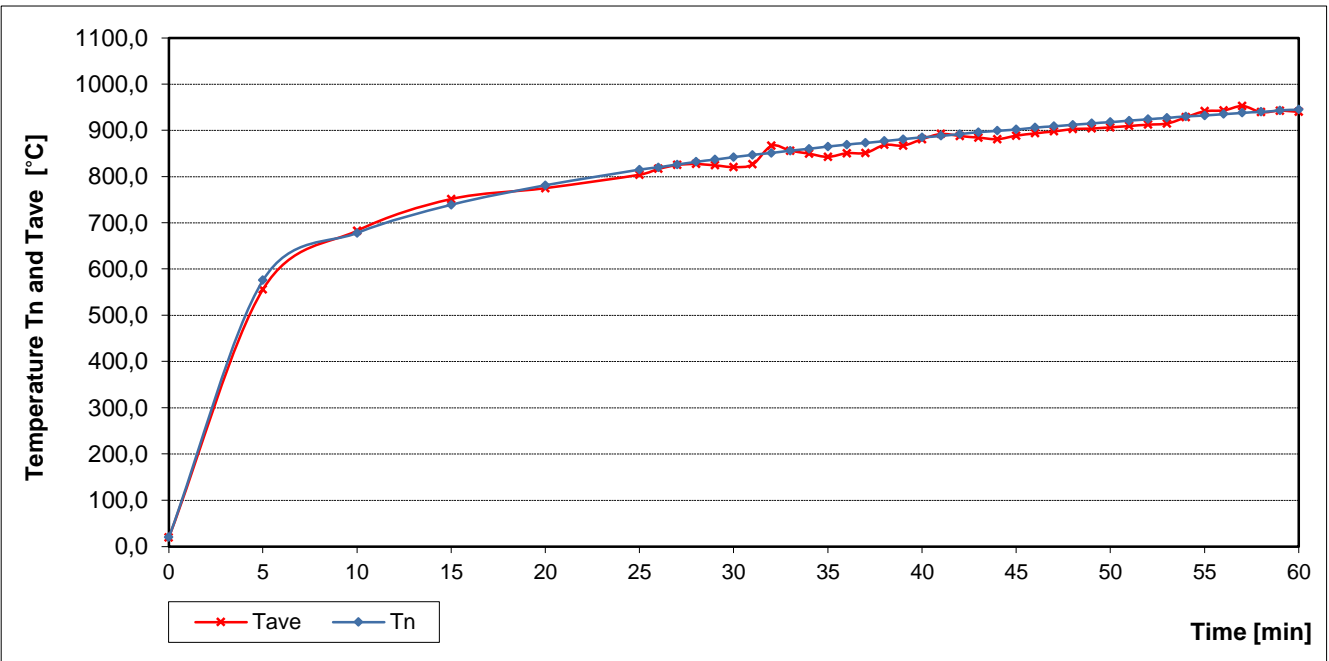
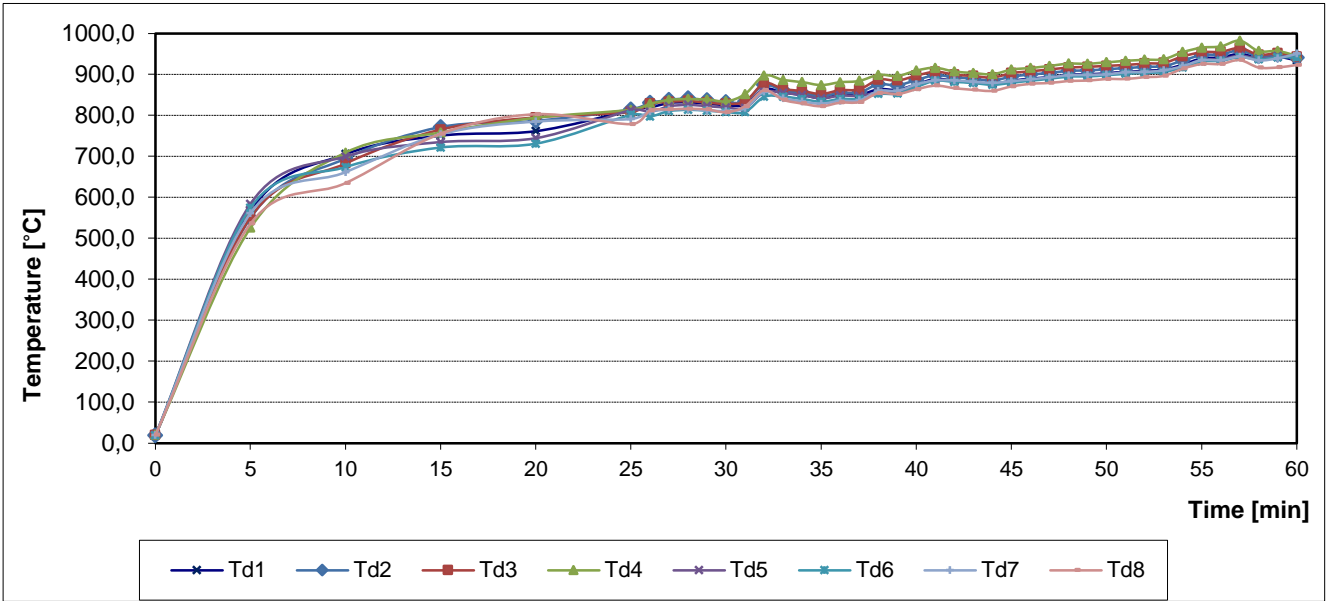



**Measured values on the unexposed surface of the test specimen No. 1**

The initial average temperature of the unexposed specimen surface: 16,7 °C

Time t [min]	Temperature rise [K]																		
	T1	T2	T3	T4	T5	T6	T7	T8	T9	T10	T11	T12	T13	T14	T15	T16	T17	T18	
0	-0,6	-1,6	-0,5	-0,9	-0,2	-0,4	-0,6	-0,1	0,6	0,1	1,0	0,9	1,0	-0,2	-1,4	2,0	1,9	1,2	
5	-0,7	-1,7	-0,8	-1,1	-0,6	-0,5	-0,9	-0,3	0,6	-0,1	0,8	0,8	0,7	1,0	-1,4	1,9	1,7	0,9	
10	-1,0	-1,5	-1,0	-1,4	-0,7	-0,7	-1,2	-0,6	0,1	-0,1	1,1	0,6	3,2	1,2	-1,3	1,7	1,2	0,5	
15	1,6	3,9	7,0	0,3	0,9	2,7	1,0	2,6	3,1	3,3	7,5	14,6	5,0	6,8	0,7	1,4	5,2	0,3	
20	11,5	16,5	14,4	7,2	8,3	15,4	12,5	18,7	18,4	13,7	17,0	24,3	15,1	25,7	7,6	1,6	9,3	1,2	
25	22,7	27,2	21,9	18,0	19,2	29,8	25,8	31,7	33,4	26,5	29,7	30,7	31,1	51,5	18,3	3,3	14,3	4,0	
26	24,9	28,9	24,0	20,3	21,8	31,8	27,9	33,8	35,5	28,6	32,7	34,3	34,1	54,0	20,4	3,9	16,1	5,2	
27	26,9	30,6	25,5	22,2	24,1	34,0	29,9	35,3	37,5	30,9	35,5	35,7	37,0	54,3	22,8	4,4	17,5	6,2	
28	28,7	32,0	27,0	24,0	26,2	35,6	31,3	36,5	39,2	32,9	37,8	37,7	39,9	57,7	25,1	5,2	18,7	7,0	
29	30,4	33,6	28,8	25,9	28,2	37,4	32,5	37,9	40,8	34,7	39,7	40,0	42,7	57,2	26,9	5,8	20,4	7,8	
30	31,9	34,8	30,8	27,7	30,4	38,9	33,8	39,1	42,0	36,4	41,8	40,7	45,4	57,5	29,2	6,5	21,5	9,0	
31	33,7	36,0	32,3	29,4	32,2	40,0	35,2	40,2	43,2	37,7	43,7	42,0	48,1	56,9	31,3	7,4	22,9	10,1	
32	35,0	37,1	34,0	30,9	33,8	41,0	35,7	41,0	44,2	39,1	45,9	43,7	50,8	56,8	33,7	8,0	24,1	11,0	
33	36,6	38,1	35,3	32,3	35,4	42,0	36,7	41,8	45,1	40,2	48,3	46,9	53,4	57,3	35,7	8,7	25,4	12,1	
34	37,6	39,2	36,5	33,6	36,8	42,8	37,3	42,4	45,8	41,2	50,3	49,6	55,8	58,0	37,4	9,8	26,6	13,1	
35	38,8	40,0	37,7	34,7	38,0	43,4	38,1	43,1	46,5	42,2	52,2	49,4	58,0	59,5	39,6	10,3	27,3	14,3	
36	40,0	40,8	38,8	35,7	39,1	44,2	38,5	43,7	47,2	43,2	53,8	49,8	59,9	61,0	41,6	11,0	27,2	15,5	
37	41,0	41,4	39,5	36,8	40,1	45,1	39,0	44,3	47,8	44,0	55,4	51,0	61,3	61,7	43,6	11,7	27,5	16,5	
38	42,1	42,7	40,6	37,7	41,0	45,6	39,3	45,1	48,4	44,8	56,5	52,2	62,9	63,8	45,9	12,5	28,0	17,8	
39	43,3	43,5	41,9	38,8	42,0	46,4	40,1	45,8	49,1	45,7	57,9	53,5	64,4	66,1	48,1	13,3	28,3	19,0	
40	44,3	44,2	42,6	39,7	42,6	47,1	40,6	46,4	49,6	46,6	59,2	54,9	66,2	68,2	50,1	14,1	28,9	20,1	
41	45,5	45,2	43,5	40,5	43,5	47,9	41,0	47,1	50,1	47,5	60,6	57,1	68,7	71,6	52,7	14,9	29,2	21,2	
42	46,7	46,0	44,5	41,3	44,2	48,5	41,5	47,7	50,6	48,4	62,2	59,3	71,8	75,1	55,0	15,7	30,4	22,3	
43	47,9	46,9	45,2	42,4	44,9	49,1	42,0	48,3	51,1	49,2	63,9	61,3	75,6	79,2	57,1	16,7	30,9	23,3	
44	48,9	47,6	45,7	43,0	45,8	49,9	42,7	49,0	51,4	49,8	65,9	63,8	80,2	84,3	59,3	17,7	32,2	24,5	
45	50,1	48,3	47,4	44,2	46,5	50,8	43,3	49,5	52,1	50,4	68,7	65,5	86,6	89,6	61,4	18,7	32,9	25,3	
46	51,2	49,3	48,8	44,8	47,5	51,4	43,9	50,1	52,6	51,3	71,1	68,2	97,7	97,7	63,9	19,5	34,3	26,4	
47	53,0	50,0	48,7	45,8	48,2	52,5	44,3	50,5	53,4	52,4	73,8	72,3	111,7	109,0	66,6	20,3	35,8	27,4	
48	54,1	50,5	48,7	46,5	48,8	53,3	44,9	51,1	53,9	53,2	77,0	75,6	128,1	124,1	69,7	21,2	36,8	28,4	
49	55,1	51,3	48,9	47,7	49,7	54,0	45,5	51,8	54,5	54,1	80,3	78,6	147,0	142,8	73,2	22,1	37,7	29,6	
50	55,7	53,7	49,5	48,1	50,7	54,8	45,8	52,5	55,0	55,3	83,0	81,1	165,9	165,3	78,1	22,6	38,8	30,6	
51	56,7	59,3	50,1	48,7	51,7	55,4	46,2	53,0	55,9	57,8	86,3	85,1	185,6	190,0	84,7	23,3	40,3	31,2	
52	57,4	62,2	50,6	49,7	52,7	56,1	46,8	53,5	56,8	59,4	90,0	91,6	207,9	221,7	92,4	24,0	42,4	32,1	
53	58,4	59,8	51,8	50,6	53,3	57,1	47,7	54,2	57,4	59,5	94,5	100,3	228,9	259,2	99,7	24,7	44,8	33,3	
54	59,7	58,9	53,1	51,5	54,0	58,1	48,1	55,0	58,2	60,1	101,1	110,2	247,8	303,1	110,1	25,7	46,5	34,4	
55	61,0	58,8	54,6	52,6	54,5	58,8	48,8	55,7	59,0	60,5	110,8	122,7	266,0	357,7	123,9	26,5	47,7	35,8	
56	62,4	59,3	55,7	53,3	55,2	59,7	49,3	56,1	60,1	61,4	123,5	136,8	279,3	414,1	141,9	27,6	49,8	37,1	
57	71,9	60,2	58,5	55,5	56,3	61,9	50,7	57,2	61,4	63,2	138,3	153,2	288,8	489,8	163,5	29,9	51,5	39,1	
58	77,3	62,3	61,1	57,2	57,8	64,5	52,5	58,8	68,4	72,8	156,9	173,1	296,3	603,8	226,9	32,2	56,1	57,9	
59					57,8	64,7					80,5	175,2	186,6		651,5	327,4		82,0	68,3
60																			

Negative values are quoted because temperature rises are calculated from the initial average temperature of the specimen surface. Please see figure showing the layout of measuring points on the specimen surface which is a part of this test report.

- Note: releasing of the thermocouples from specimen No. 1 surface. Termination of the temperature measurement.
- Note2: measured values from 44. minutes have only informative character, because of specimen No. 1 integrity failure.



Measured values on the unexposed surface of the test specimen No. 1 / graph

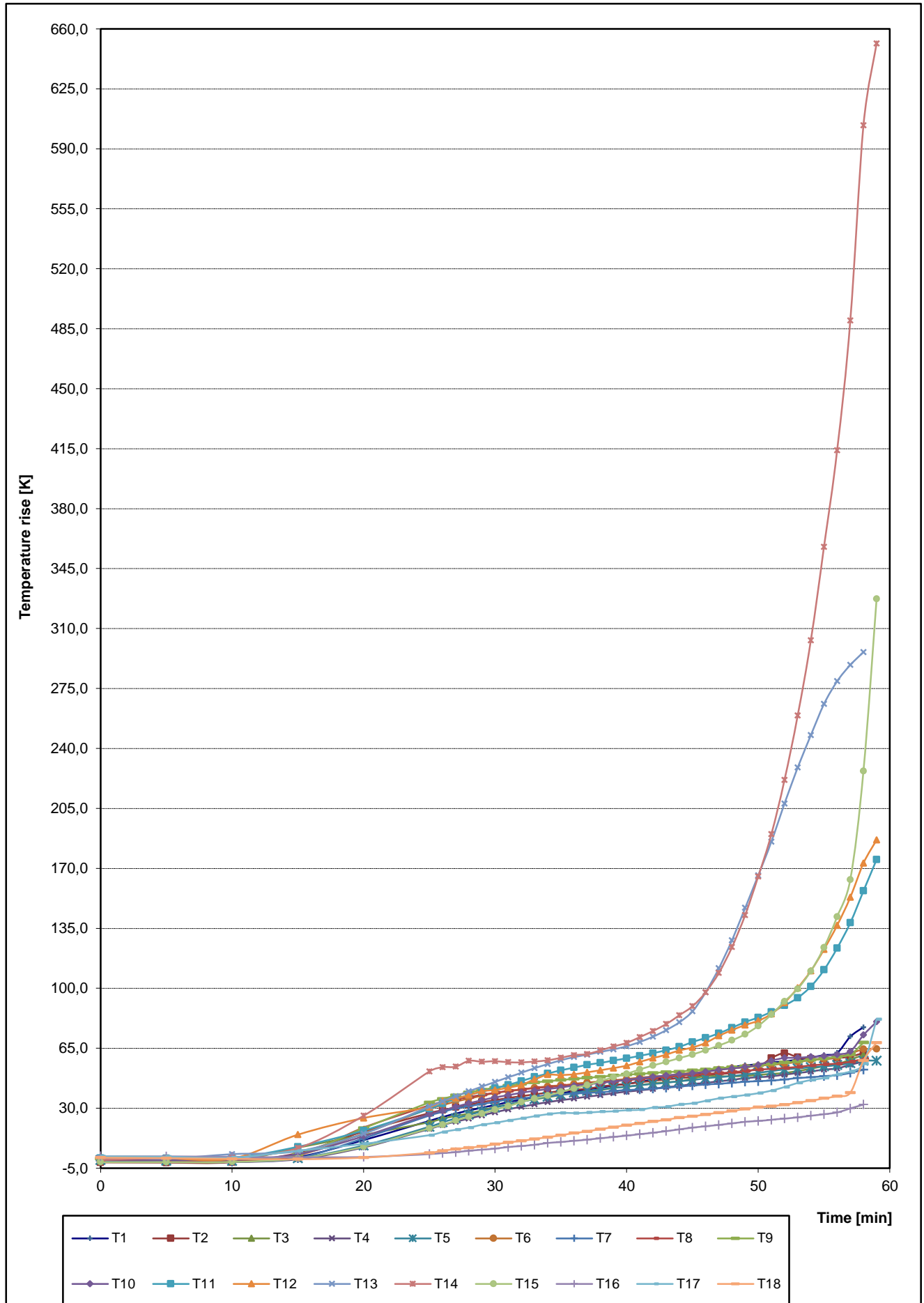







**Measured values on the unexposed surface of the test specimen No. 1**  
**Calculated values from measured values on the specimen No. 1 surface**

The initial average temperature of the unexposed specimen surface: **16,7 °C**

Time t [min]	Temperature rise [K]			
	T19	T20	T21	T22
0	1,4	0,1	0,5	0,8
5	1,3	-0,2	1,0	0,5
10	0,7	-0,5	1,5	0,5
15	3,4	-0,9	5,2	14,9
20	12,2	-0,5	15,4	25,4
25	17,5	1,3	26,0	33,4
26	18,7	1,9	28,3	35,6
27	20,3	2,4	30,2	37,2
28	22,7	3,1	32,0	39,0
29	25,6	3,7	33,9	40,8
30	27,5	4,7	35,7	42,4
31	28,1	5,5	37,1	43,8
32	25,8	6,3	38,6	45,4
33	24,1	7,4	40,0	46,4
34	23,7	8,0	41,0	47,6
35	24,1	9,1	42,3	48,5
36	23,8	10,0	43,3	49,7
37	24,5	10,9	44,2	50,4
38	25,1	12,1	45,1	51,3
39	26,4	13,2	46,1	52,6
40	26,7	14,2	47,0	53,4
41	27,3	15,5	47,8	54,2
42	28,0	16,6	48,7	55,4
43	28,8	18,0	49,5	56,2
44	29,6	19,1	50,5	56,5
45	30,6	20,4	51,3	59,0
46	31,5	21,8	52,0	60,8
47	32,1	23,5	52,7	60,1
48	33,5	24,7	53,5	59,2
49	34,8	26,2	54,5	57,8
50	34,3	27,9	55,7	57,4
51	34,5	30,6	56,0	57,4
52	37,2	32,5	57,0	57,6
53	40,6	33,5	58,2	58,7
54	43,0	34,7	59,2	60,5
55	46,2	35,9	60,3	62,7
56	50,0	37,1	61,0	64,7
57	53,1	39,4	62,5	67,7
58	172,1	53,0	64,5	70,6
59	256,9			
60				

Time t [min]	Temperature rise [K]			
	TRave1	TRmax1	TRmax-S1	TRmax-F1
0	-0,8	0,8	1,0	2,0
5	-1,0	1,0	1,0	1,9
10	-1,1	1,5	3,2	1,7
15	2,7	14,9	14,9	5,2
20	11,6	25,4	25,7	12,2
25	21,8	33,4	51,5	17,5
26	24,0	35,6	54,0	18,7
27	25,9	37,5	54,3	20,3
28	27,6	39,2	57,7	22,7
29	29,4	40,8	57,2	25,6
30	31,1	42,4	57,5	27,5
31	32,7	43,8	56,9	28,1
32	34,2	45,4	56,8	25,8
33	35,5	46,4	57,3	25,4
34	36,7	47,6	58,0	26,6
35	37,8	48,5	59,5	27,3
36	38,9	49,7	61,0	27,2
37	39,8	50,4	61,7	27,5
38	40,8	51,3	63,8	28,0
39	41,9	52,6	66,1	28,3
40	42,7	53,4	68,2	28,9
41	43,6	54,2	71,6	29,2
42	44,5	55,4	75,1	30,4
43	45,5	56,2	79,2	30,9
44	46,2	56,5	84,3	32,2
45	47,3	59,0	89,6	32,9
46	48,3	60,8	97,7	34,3
47	49,1	60,1	111,7	35,8
48	49,7	59,2	128,1	36,8
49	50,5	57,8	147,0	37,7
50	51,5	57,4	165,9	38,8
51	53,3	59,3	<b>190,0</b>	40,3
52	54,5	62,2	221,7	42,4
53	54,8	59,8	259,2	44,8
54	55,4	60,5	303,1	46,5
55	56,3	62,7	357,7	47,7
56	57,2	64,7	414,1	50,0
57	60,5	71,9	489,8	53,1
58	63,1	77,3	603,8	172,1
59	57,8	80,5	651,5	256,9
60				

Negative values are quoted because temperature rises are calculated from the initial average temperature of the specimen surface. Please see figure showing the layout of measuring points on the specimen surface which is a part of this test report.

 Note: releasing of the thermocouples from specimen No. 1 surface. Termination of the temperature measurement.  
 Note2: measured values from 44. minutes have only informative character, because of specimen No. 1 integrity failure.

- TRave1** average temperature rise above initial average temperature calculated from T1-T5
- TRmax1** maximal temperature rise above initial average temperature calculated from T1-T10; T21-T22
- TRmax-S1** maximal temperature rise above initial average temperature calculated from T1-T15; T21-T22 - supplementary procedure
- TRmax-F1** maximal temperature rise above initial average temperature calculated from T16-T20 - door frame



**Measured values on the unexposed surface of the test specimen No. 1 / graph**

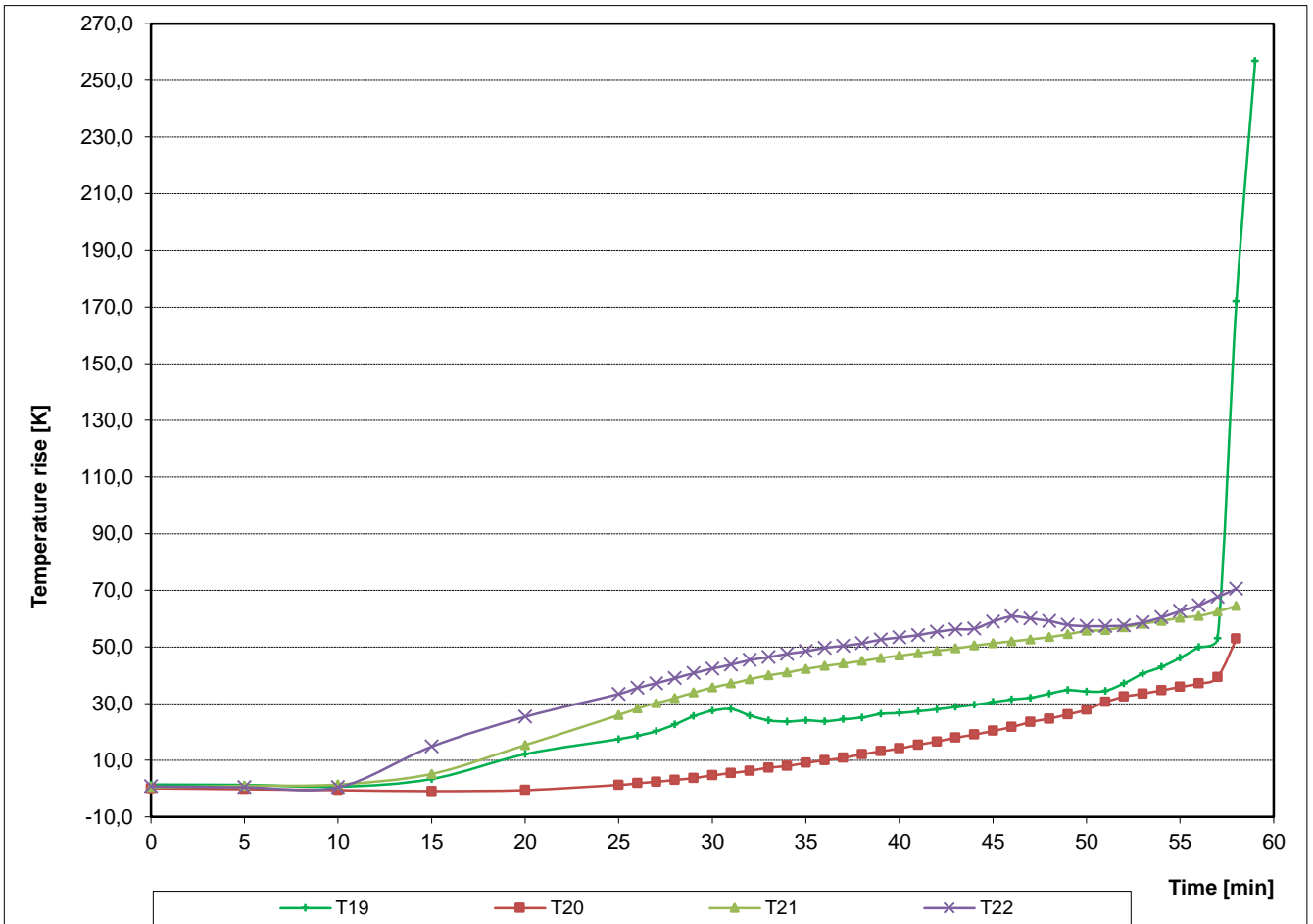

**Calculated values from measured values on the specimen No. 1 surface / graph**

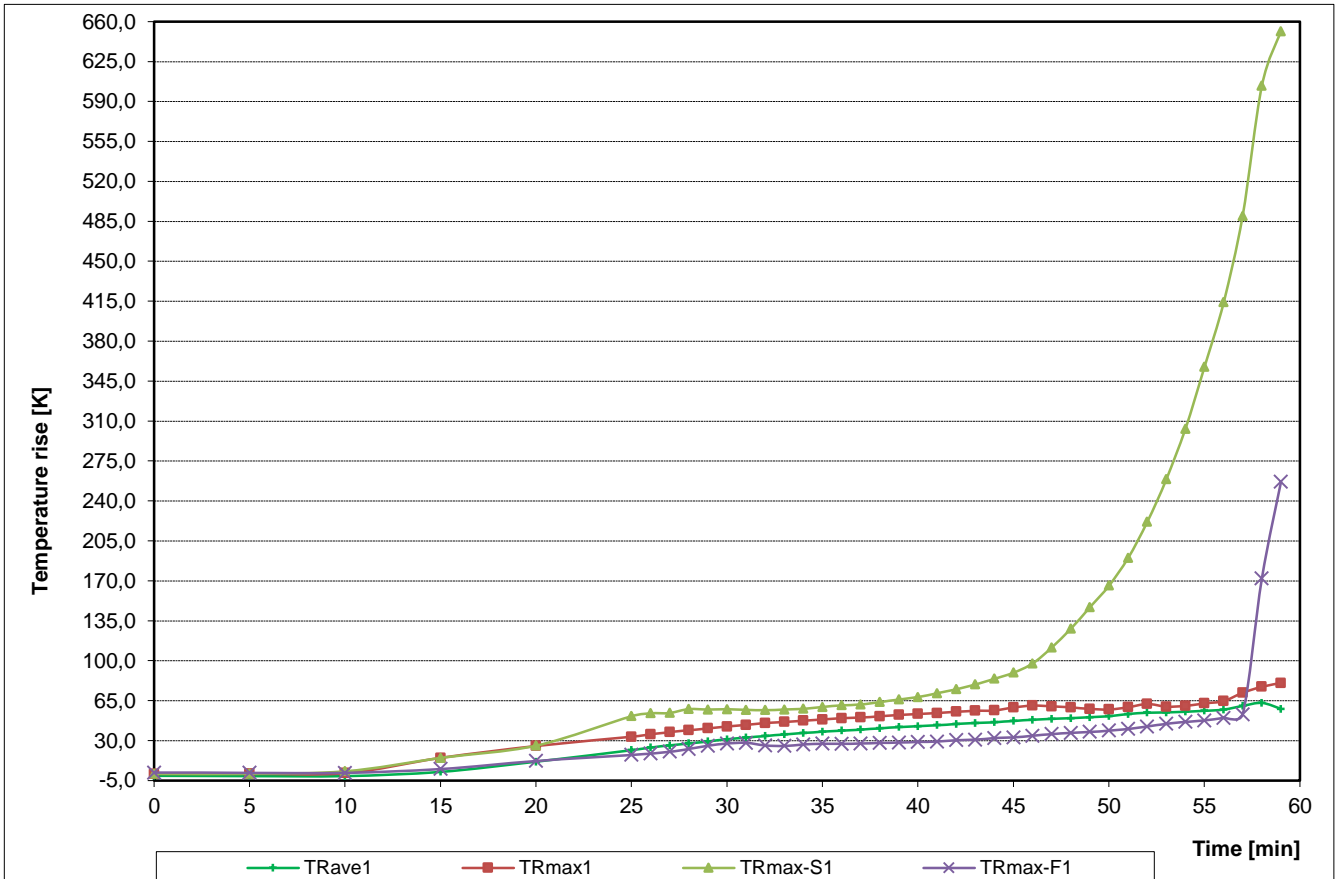



**Measured values on the unexposed surface of the test specimen No. 2**

The initial average temperature of the unexposed specimen surface: 16,4 °C

Time t [min]	Temperature rise [K]																	
	T31	T32	T33	T34	T35	T36	T37	T38	T39	T40	T41	T42	T43	T44	T45	T46	T47	T48
0	0,8	0,8	0,4	0,3	-0,1	-0,8	-0,2	0,7	0,6	0,3	-0,2	-0,5	-0,3	-0,3	-0,8	-0,8	-0,4	0,0
5	0,8	0,6	0,2	-0,1	-0,3	-1,1	-0,5	0,5	0,3	0,0	-0,5	-1,0	-0,6	-0,4	-1,0	-1,0	-0,4	-0,2
10	0,7	0,7	0,0	-0,1	-0,6	-1,3	-0,7	0,3	0,0	0,0	-0,6	-1,3	4,2	-0,4	-0,9	-1,4	-0,8	-0,5
15	2,1	2,3	2,9	2,6	1,5	0,6	1,4	2,6	3,8	3,2	0,4	-0,4	5,6	4,6	10,6	-1,6	-0,4	-0,5
20	6,3	7,7	10,5	8,2	7,2	5,7	8,5	9,7	11,5	9,9	4,1	6,4	8,0	10,9	17,6	-0,5	2,7	1,7
25	12,6	14,3	16,2	14,2	13,7	12,0	16,0	16,8	19,2	17,3	9,6	16,5	12,7	19,2	23,3	3,3	8,3	6,1
26	14,2	15,5	17,2	15,6	15,1	13,2	17,4	18,2	20,7	18,7	10,9	17,0	13,9	21,1	24,6	4,4	9,4	7,0
27	15,5	17,0	18,6	16,9	16,5	14,3	18,7	19,5	22,0	20,1	12,2	18,1	15,0	22,6	26,4	5,9	10,5	8,1
28	17,1	18,3	20,0	18,1	17,9	15,8	20,2	21,0	23,4	21,6	13,5	19,5	16,4	23,9	28,0	7,1	11,7	9,1
29	18,7	19,9	21,1	19,2	19,2	17,1	21,6	22,2	24,7	22,9	14,8	21,1	17,6	24,8	29,8	8,3	13,0	10,3
30	20,3	21,2	22,8	20,6	20,6	18,5	22,8	23,8	26,2	24,4	16,4	21,7	19,3	27,2	31,5	10,2	14,1	11,4
31	21,6	22,6	24,1	21,8	22,1	19,6	24,2	25,1	27,4	25,7	18,1	23,9	20,8	28,5	33,2	12,1	15,5	12,6
32	23,3	24,3	26,8	23,2	23,5	21,3	25,8	26,8	28,8	27,1	19,7	25,6	22,8	30,0	35,4	14,0	16,8	14,1
33	24,9	25,8	28,0	24,6	24,9	22,6	27,0	28,1	30,1	28,5	21,1	26,9	24,6	31,8	37,3	15,9	18,0	15,4
34	26,7	27,2	29,3	25,8	26,3	23,8	28,4	29,6	31,3	30,1	22,5	29,0	26,6	33,1	39,0	18,1	19,5	16,6
35	28,3	28,8	31,2	27,1	27,8	25,4	29,6	31,2	32,7	31,6	24,2	30,7	28,6	35,2	41,0	21,0	20,7	18,0
36	30,2	30,4	33,2	28,7	29,6	27,3	31,0	32,8	34,1	33,2	25,8	33,1	31,0	37,4	43,4	24,9	22,3	19,6
37	31,9	32,4	34,9	30,0	31,3	28,6	32,4	34,3	35,4	34,7	27,1	34,8	33,2	39,6	45,6	28,7	23,9	20,9
38	33,8	33,7	36,5	31,4	32,7	30,1	33,8	35,8	36,9	36,2	28,9	36,1	35,6	41,5	47,3	32,6	25,2	22,4
39	35,6	35,0	38,1	32,6	34,2	31,6	35,0	37,1	38,0	37,5	30,6	38,3	37,9	43,2	48,8	34,5	27,1	23,9
40	37,3	36,8	39,5	33,9	35,8	33,3	36,3	38,5	39,3	39,0	32,2	40,2	40,1	45,7	50,7	37,0	28,9	25,3
41	39,5	38,5	41,6	35,7	37,4	35,2	37,8	40,2	40,5	40,6	34,0	41,8	42,7	48,3	52,6	39,3	30,5	27,3
42	41,3	40,0	43,1	36,8	38,9	36,6	38,7	41,4	41,6	41,9	35,5	42,7	44,9	50,1	53,3	41,3	31,7	29,1
43	43,1	41,4	44,5	37,9	40,2	38,1	39,8	42,6	42,7	43,1	37,0	43,9	47,8	53,1	54,7	42,4	33,2	31,1
44	45,0	42,6	46,1	39,1	41,6	39,7	41,0	44,0	43,9	44,5	38,3	45,2	50,7	55,7	56,0	43,4	34,8	33,2
45	46,8	44,1	47,6	40,2	43,1	41,3	42,0	45,3	45,0	45,9	40,3	46,8	54,0	58,6	56,7	43,8	36,3	35,1
46	49,0	45,8	49,4	41,7	44,7	43,1	43,3	46,9	46,3	47,3	42,3	48,9	57,6	61,2	57,7	44,8	38,2	37,2
47	50,8	46,9	50,9	42,9	45,9	44,9	44,6	48,2	47,4	48,5	44,0	50,6	61,5	63,1	58,5	45,2	40,0	38,7
48	52,7	48,2	52,5	44,1	47,2	46,7	45,7	49,3	48,7	49,7	46,0	52,4	65,8	65,2	59,9	45,3	42,2	40,5
49	54,6	49,8	54,3	45,3	48,8	48,2	46,9	50,7	50,1	51,2	48,1	54,1	70,6	67,0	61,2	45,9	44,4	43,5
50	56,4	51,2	56,0	47,0	50,3	50,1	48,2	52,0	51,0	52,3	49,5	55,7	76,5	68,1	62,9	46,8	46,8	45,5
51	58,4	52,7	57,8	48,1	51,8	51,7	49,4	53,5	52,2	53,4	50,8	56,9	83,3	69,4	64,9	47,4	49,1	46,9
52	62,1	54,1	59,4	49,2	53,1	53,6	50,4	55,0	53,5	54,5	52,3	58,1	92,4	70,3	66,6	47,4	51,0	48,5
53	65,3	55,5	60,6	50,5	54,3	55,1	51,4	56,2	54,7	55,8	53,9	59,6	104,3	71,6	68,7	49,3	52,4	50,4
54	64,8	56,6	62,0	51,7	55,3	56,4	52,5	57,5	55,8	57,0	55,2	61,2	118,9	72,6	70,7	50,4	54,3	51,0
55	64,7	57,6	63,2	52,9	56,4	57,0	53,5	58,8	56,9	58,1	56,0	62,5	136,1	73,6	73,5	50,0	55,9	51,2
56	65,2	59,6	64,5	53,7	57,4	58,0	54,5	59,8	57,9	59,3	57,1	64,1	155,8	75,4	75,8	48,4	57,4	52,3
57	65,9	65,0	66,3	54,7	58,7	58,7	55,3	60,7	59,2	61,3	58,4	66,0	176,9	77,6	78,2	47,3	58,9	52,7
58	66,7	74,0	69,3	56,0	60,8	59,8	56,5	62,4	60,8	64,0	60,1	68,3	200,1	81,2	81,7	47,1	61,3	55,7
59	67,7	79,7	70,9	57,9	62,9	61,5	58,1	63,8	62,6	66,9	60,5	71,5	222,8	86,5	87,1	47,9	65,0	62,2
60	66,2	79,6	72,0	59,1	64,0	61,2	59,0	65,2	63,6	69,1	59,0	73,9	243,2	94,7	92,7	46,7	68,2	70,3

Negative values are quoted because temperature rises are calculated from the initial average temperature of the specimen surface. Please see figure showing the layout of measuring points on the specimen surface which is a part of this test report.

*Note: measured values from 50. minutes have only informative character, because of specimen No. 2 integrity failure.*



Measured values on the unexposed surface of the test specimen No. 2 / graph

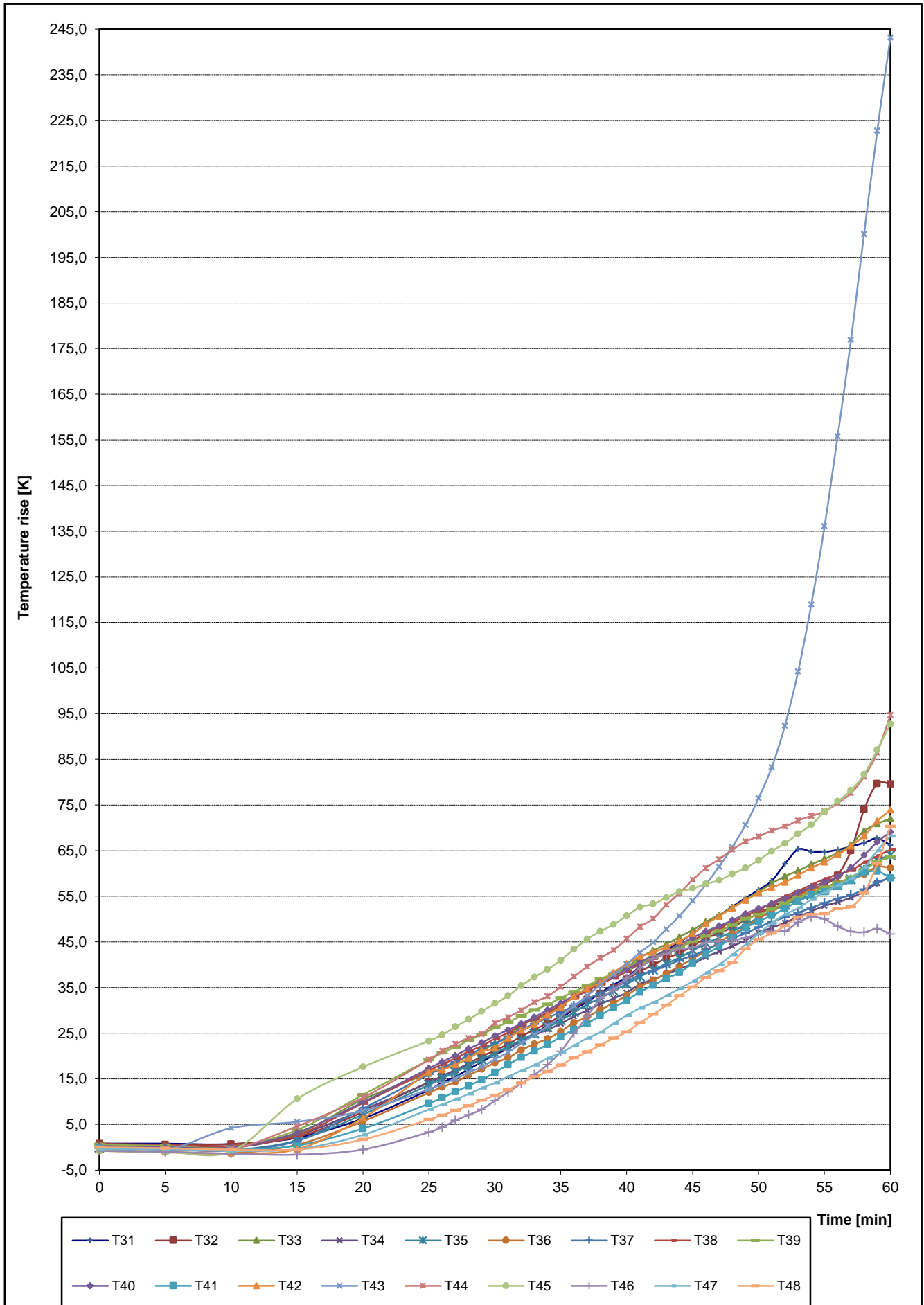





**Measured values on the unexposed surface of the test specimen No. 2**  
**Calculated values from measured values on the specimen No. 2 surface**

The initial average temperature of the unexposed specimen surface: **16,4 °C**

Time t [min]	Temperature rise [K]			
	T49	T50	T51	T52
0	1,4	-0,2	-0,9	-1,3
5	1,0	-0,5	-0,4	-1,6
10	0,5	-0,7	0,6	-1,4
15	2,0	3,4	3,1	3,9
20	3,8	8,2	9,6	18,3
25	9,1	13,5	16,1	22,7
26	10,6	14,6	17,2	24,6
27	11,8	15,9	18,5	26,3
28	12,9	17,4	19,3	27,8
29	14,2	18,5	20,8	29,3
30	15,8	19,1	22,1	31,3
31	16,9	19,9	23,4	33,1
32	18,3	20,6	25,2	38,0
33	19,7	21,5	26,6	39,2
34	20,7	22,7	28,0	40,5
35	22,1	23,6	29,5	42,8
36	23,4	24,2	31,3	45,3
37	24,6	25,4	32,9	47,2
38	25,9	26,3	34,5	49,0
39	26,9	27,7	35,6	50,6
40	27,8	29,0	37,2	51,8
41	29,1	30,3	39,0	54,2
42	30,1	32,1	40,1	55,1
43	31,2	33,0	41,3	56,1
44	32,3	34,4	42,6	57,7
45	33,5	35,4	43,8	58,8
46	34,6	37,0	45,5	60,9
47	35,7	39,0	46,7	61,7
48	36,7	42,5	48,1	63,3
49	37,9	48,2	49,5	64,9
50	39,0	55,2	50,7	66,8
51	40,1	59,5	51,8	67,2
52	41,3	62,5	53,3	68,1
53	42,5	65,0	54,4	69,1
54	44,0	67,0	55,8	70,9
55	45,6	68,0	57,0	72,5
56	47,0	68,1	58,2	73,6
57	48,4	68,2	59,7	75,8
58	50,5	69,3	61,7	79,7
59	53,5	70,7	63,6	80,7
60	56,1	72,3	64,8	81,9

Time t [min]	Temperature rise [K]			
	TRave2	TRmax2	TRmax-S2	TRmax-F2
0	0,4	0,8	0,8	1,4
5	0,2	0,8	0,8	1,0
10	0,1	0,7	4,2	0,5
15	2,3	3,9	10,6	3,4
20	8,0	18,3	18,3	8,2
25	14,2	22,7	23,3	13,5
26	15,5	24,6	24,6	14,6
27	16,9	26,3	26,4	15,9
28	18,3	27,8	28,0	17,4
29	19,6	29,3	29,8	18,5
30	21,1	31,3	31,5	19,1
31	22,4	33,1	33,2	19,9
32	24,2	38,0	38,0	20,6
33	25,6	39,2	39,2	21,5
34	27,1	40,5	40,5	22,7
35	28,6	42,8	42,8	23,6
36	30,4	45,3	45,3	24,9
37	32,1	47,2	47,2	28,7
38	33,6	49,0	49,0	32,6
39	35,1	50,6	50,6	34,5
40	36,7	51,8	51,8	37,0
41	38,5	54,2	54,2	39,3
42	40,0	55,1	55,1	41,3
43	41,4	56,1	56,1	42,4
44	42,9	57,7	57,7	43,4
45	44,4	58,8	58,8	43,8
46	46,1	60,9	61,2	44,8
47	47,5	61,7	63,1	45,2
48	48,9	63,3	65,8	45,3
49	50,6	64,9	70,6	48,2
50	52,2	66,8	76,5	55,2
51	53,8	67,2	83,3	59,5
52	55,6	68,1	92,4	62,5
53	57,2	69,1	104,3	65,0
54	58,1	70,9	118,9	67,0
55	59,0	72,5	136,1	68,0
56	60,1	73,6	155,8	68,1
57	62,1	75,8	176,9	68,2
58	65,4	79,7	200,1	69,3
59	67,8	80,7	222,8	70,7
60	68,2	81,9	243,2	72,3

Negative values are quoted because temperature rises are calculated from the initial average temperature of the specimen surface. Please see figure showing the layout of measuring points on the specimen surface which is a part of this test report.



Note: releasing of the thermocouples from specimen No. 2 surface. Termination of the temperature measurement.  
 Note2: measured values from 50. minutes have only informative character, because of specimen No. 2 integrity failure.

- TRave2** average temperature rise above initial average temperature calculated from T31-T35
- TRmax2** maximal temperature rise above initial average temperature calculated from T31-T40; T51-T52
- TRmax-S2** maximal temperature rise above initial average temperature calculated from T31-T45; T51-T52 - supplementary procedure
- TRmax-F2** maximal temperature rise above initial average temperature calculated from T46-T50 - door frame



**Measured values on the unexposed surface of the test specimen No. 2 / graph**

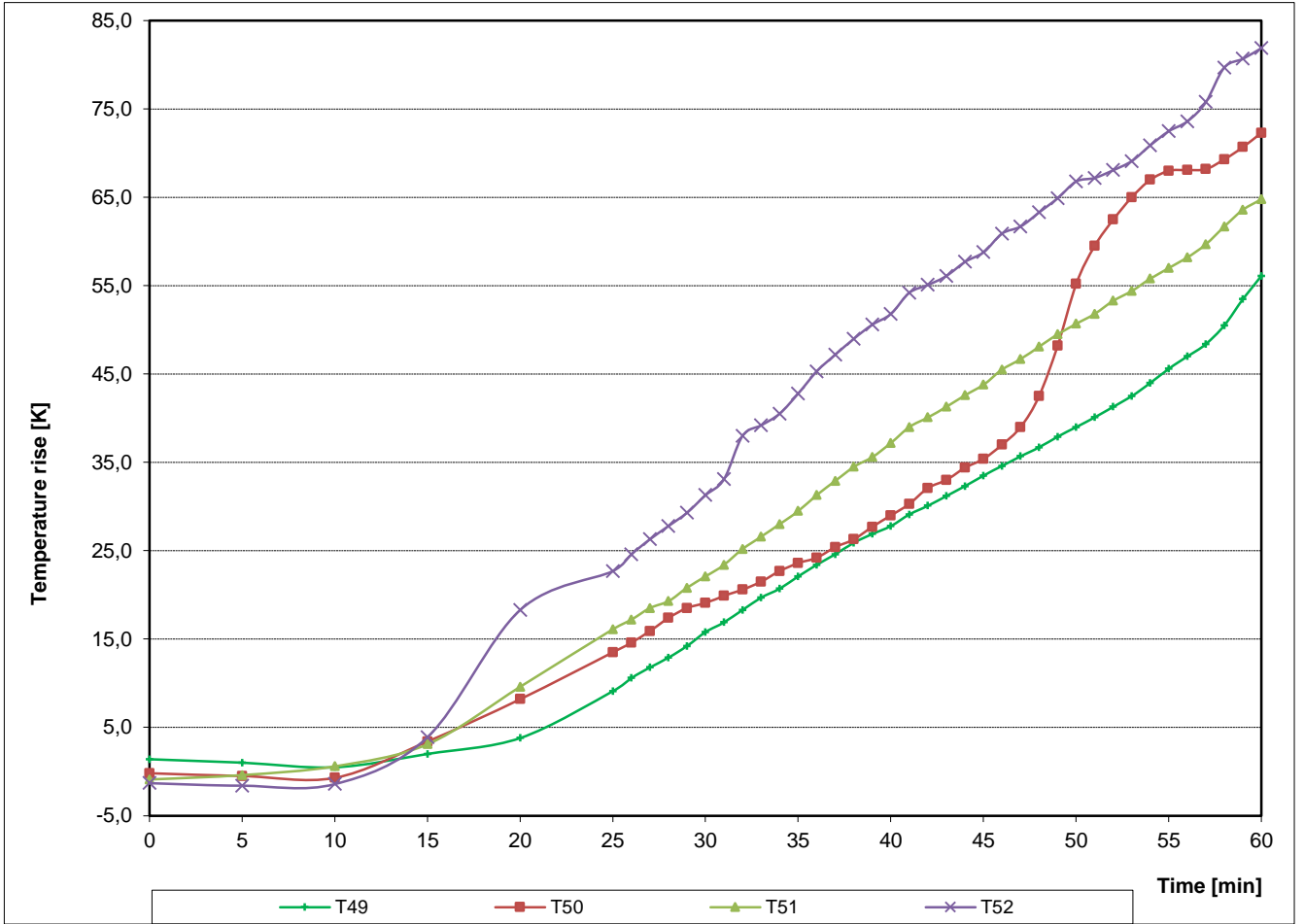

**Calculated values from measured values on the specimen No. 2 surface / graph**

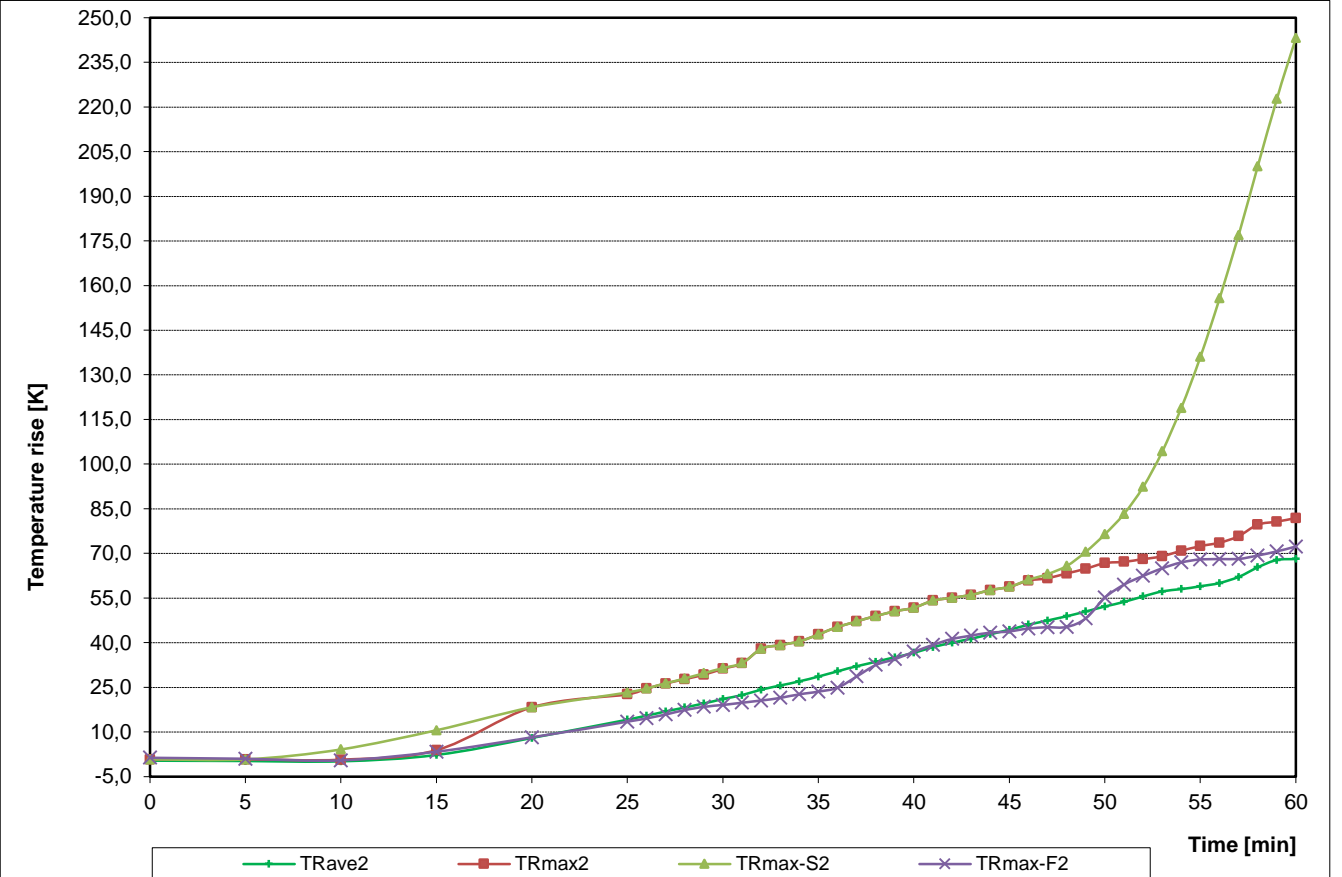



**Deflection of the specimens**

Time t [min]	Deflection [mm]																
	D1	D2	D3	D4	D5	D6	D7	D8	D9	D10	D11	D12	D13	D14	D15	D16	D17
0	0,0	0,0	0,0	0,0	0,0	0,0	0,0	0,0	0,0	0,0	0,0	0,0	0,0	0,0	0,0	0,0	0,0
5	0,1	0,0	0,3	0,4	0,1	2,3	0,1	1,2	5,0	-1,0	5,0	4,0	1,0	0,0	3,0	3,0	1,0
10	0,4	0,4	0,9	1,0	0,5	4,8	2,3	3,5	10,0	0,0	1,0	7,0	1,0	0,0	3,0	7,0	2,0
15	0,5	0,4	1,0	1,1	0,6	5,5	2,9	4,0	10,0	-1,0	1,0	8,0	2,0	1,0	3,0	7,0	3,0
20	3,0	2,5	5,9	8,2	4,6	6,1	3,2	4,2	9,0	0,0	0,0	11,0	2,0	1,0	3,0	7,0	3,0
25	2,9	2,5	5,9	9,7	5,2	6,3	3,4	4,5	10,0	0,0	0,0	12,0	3,0	2,0	3,0	7,0	4,0
26	2,9	2,5	5,9	9,9	5,3	6,4	3,5	4,6									
27	2,9	2,5	5,9	10,1	5,6	6,6	4,3	4,7									
28	2,9	2,5	5,9	10,3	5,8	6,6	4,3	4,6									
29	2,9	2,5	5,9	10,5	5,9	6,6	4,3	4,7									
30	2,9	2,5	5,9	11,0	6,1	6,7	4,4	4,8	10,0	-1,0	0,0	12,0	2,0	1,0	3,0	7,0	3,0
31	2,9	2,5	5,9	11,2	6,3	6,7	4,5	4,9									
32	2,9	2,5	5,9	11,6	6,5	6,8	5,5	5,0									
33	2,9	3,0	5,9	11,9	6,7	6,8	5,5	5,0									
34	2,9	3,3	5,9	12,2	7,0	6,8	5,5	5,0									
35	2,9	3,7	5,9	12,5	7,2	6,8	5,7	5,2	10,0	0,0	0,0	12,0	3,0	2,0	3,0	7,0	3,0
36	3,0	3,8	6,0	12,9	7,5	6,8	5,8	5,3									
37	3,3	4,4	6,3	13,5	7,9	6,8	6,6	5,4									
38	4,0	4,8	6,5	14,0	8,1	7,0	6,6	5,5									
39	4,5	5,5	6,8	14,6	8,6	7,3	7,0	6,0									
40	5,0	5,9	7,3	15,3	9,0	7,5	7,5	6,4	12,0	-1,0	2,0	13,0	2,0	1,0	3,0	7,0	3,0
41	5,9	6,8	7,7	16,1	9,7	7,9	8,6	6,8									
42	6,7	7,9	8,6	16,9	10,5	8,5	9,0	7,2									
43	7,6	8,8	9,5	18,0	11,5	9,2	9,9	8,0									
44	8,5	9,7	10,3	19,1	12,9	10,1	11,2	8,9									
45	9,2	10,6	11,0	20,3	14,0	11,1	12,3	10,0	12,0	0,0	2,0	13,0	3,0	1,0	3,0	7,0	4,0
46	9,6	11,2	11,7	21,5	15,2	12,0	13,4	11,0									
47	10,0	11,6	12,3	22,8	16,4	12,7	14,6	11,8									
48	10,1	11,6	12,7	23,6	17,4	13,3	15,3	12,5									
49	10,2	11,8	13,0	24,7	18,5	14,0	16,0	13,1									
50	10,2	11,9	13,2	25,5	19,5	14,5	16,6	13,4	13,0	0,0	3,0	13,0	4,0	2,0	3,0	7,0	4,0
51	10,2	11,9	13,3	26,4	20,2	15,0	17,0	13,7									
52	10,2	11,9	13,4	27,2	21,2	15,5	17,5	14,2									
53	10,2	11,9	13,4	27,7	22,3	15,8	17,8	14,4									
54	10,2	11,9	13,3	28,3	22,9	16,1	18,0	14,6									
55	10,2	11,9	12,9	28,7	23,8	16,2	18,1	14,7	13,0	0,0	3,0	14,0	5,0	3,0	3,0	7,0	5,0
56	10,2	11,9	12,0	29,5	24,6	16,2	18,1	14,7									
57	10,2	11,9	10,6	29,7	25,2	16,2	18,1	14,7									
58	10,2	11,8	10,1	27,7	26,2	16,2	18,1	14,7									
59	10,2	11,6	7,8	27,5	26,8	16,2	18,1	14,7									
60	9,4	9,9	4,2	27,6	27,5	16,1	18,0	14,7	14,0	1,0	2,0	13,0	5,0	3,0	3,0	7,0	5,0

Please see figure showing the layout of measuring points of deflection on the specimen surface which is a part of this test report.

**Deflection [mm] - specimens deflection**

**D1 to D8** Deflection measured with cable position transducer

**D9 to D17** Deflection measured by laser beam

Positive values of deflection represent deflection to the heat stress.

Negative values of deflection represent deflection from the heat stress.



### Deflection of the specimens / graph

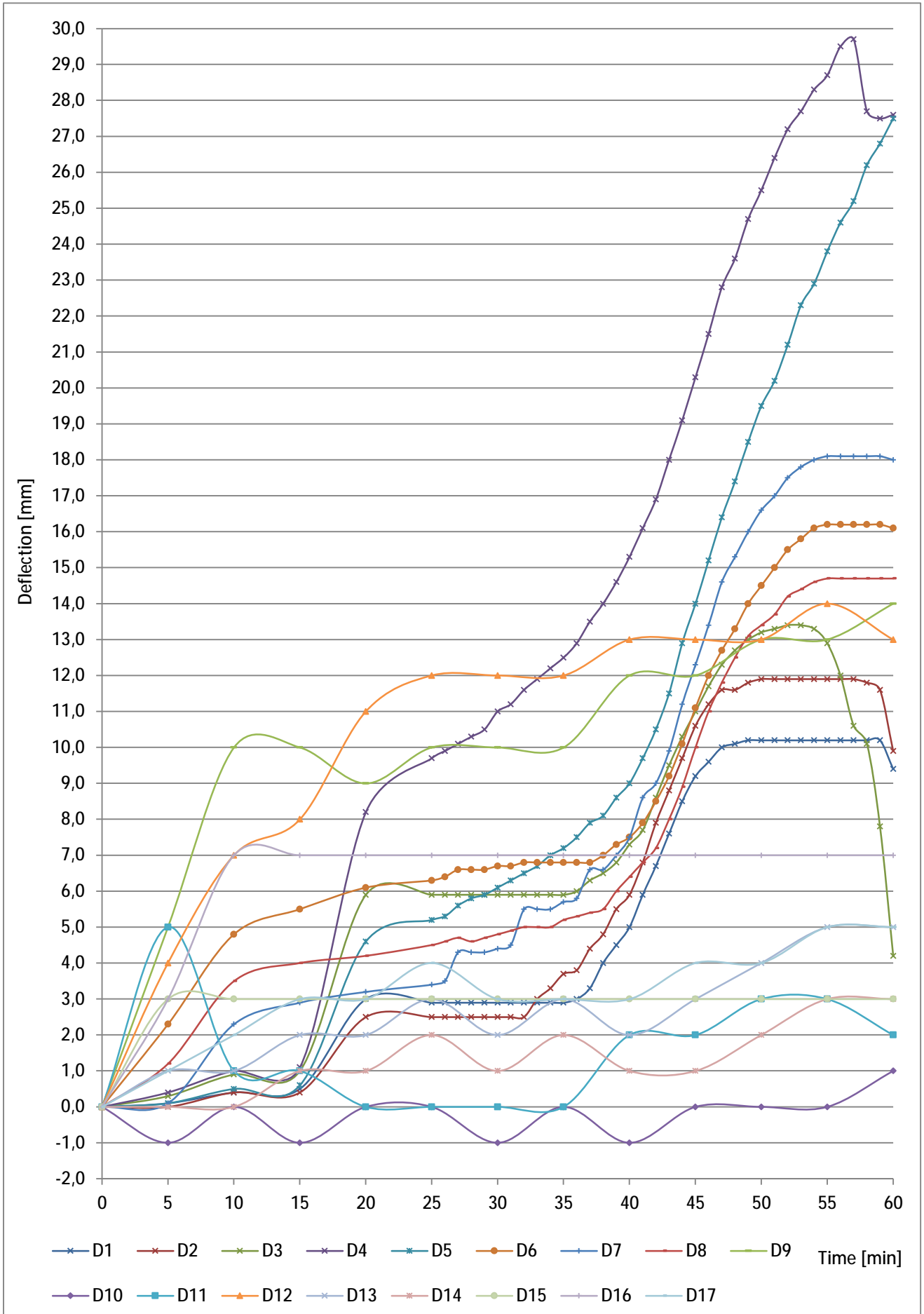





**Layout of measuring points on the unexposed specimens surface**

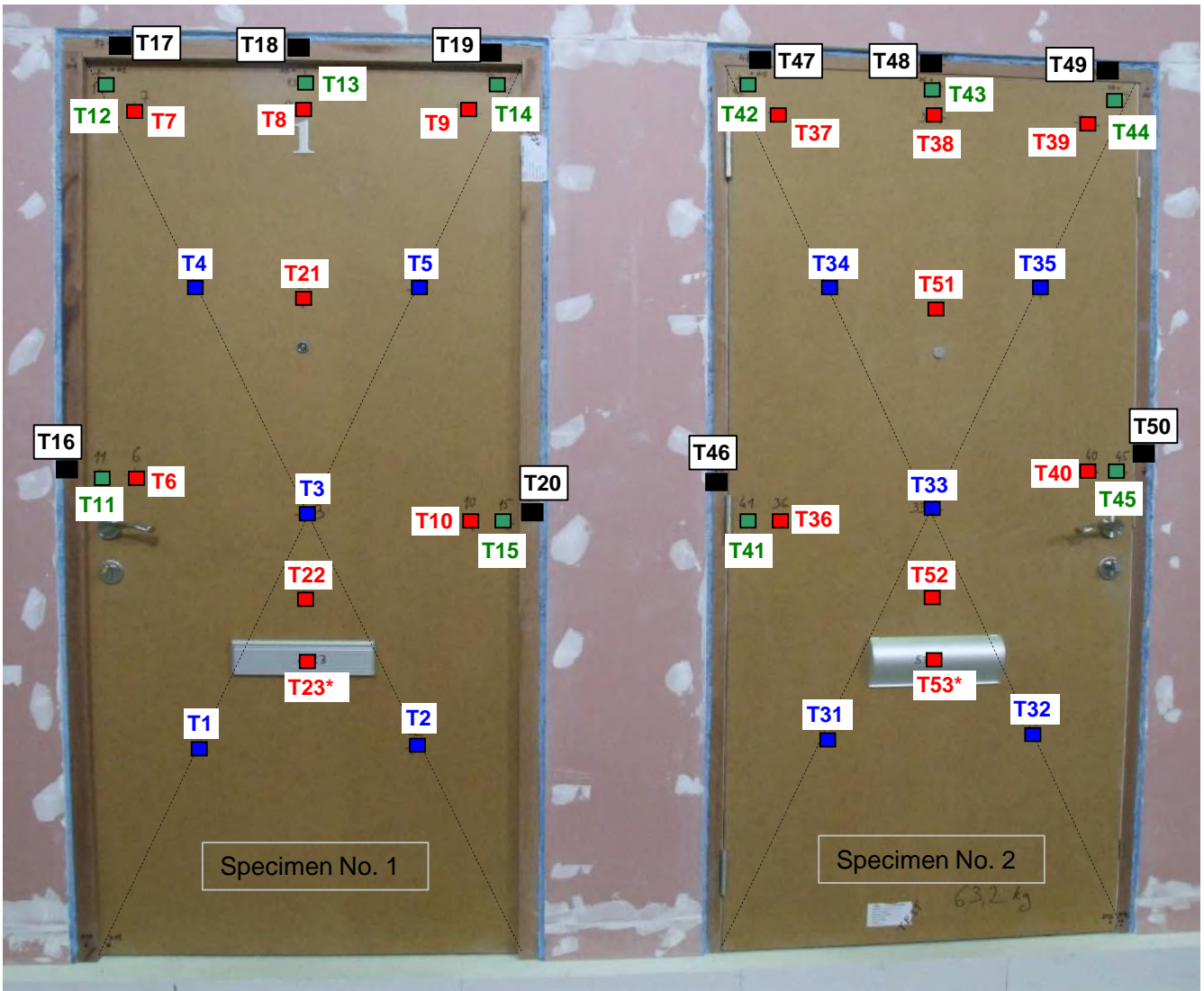

- Thermocouples attached for the average and maximum temperature rise evaluation according to EN 1634-1
- Thermocouples attached for the maximum temperature rise evaluation according to EN 1634-1
- Thermocouples attached for the maximum temperature rise evaluation (supplementary procedure) according to EN 1634-1
- Thermocouples attached for the maximum temperature rise evaluation (on the door frame) according to EN 1634-1

*\*Note: Thermocouples attached on the discrete area (letter plate) for the maximum temperature rise have only informative character and are not a subject of evaluation, because the overall dimensions of discrete area (letter plate) are less than 0,1 m<sup>2</sup> and therefore a separate thermocouple is not necessary acc. to EN 1363-1. (The measured values are stored in the laboratory archive.)*



**Specimens deflection - layout of the measuring points**



**Deflection [mm] - specimens deflection**

- D1 to D8                      Deflection measured with cable position transducer
- D9 to D17                    Deflection measured by laser beam

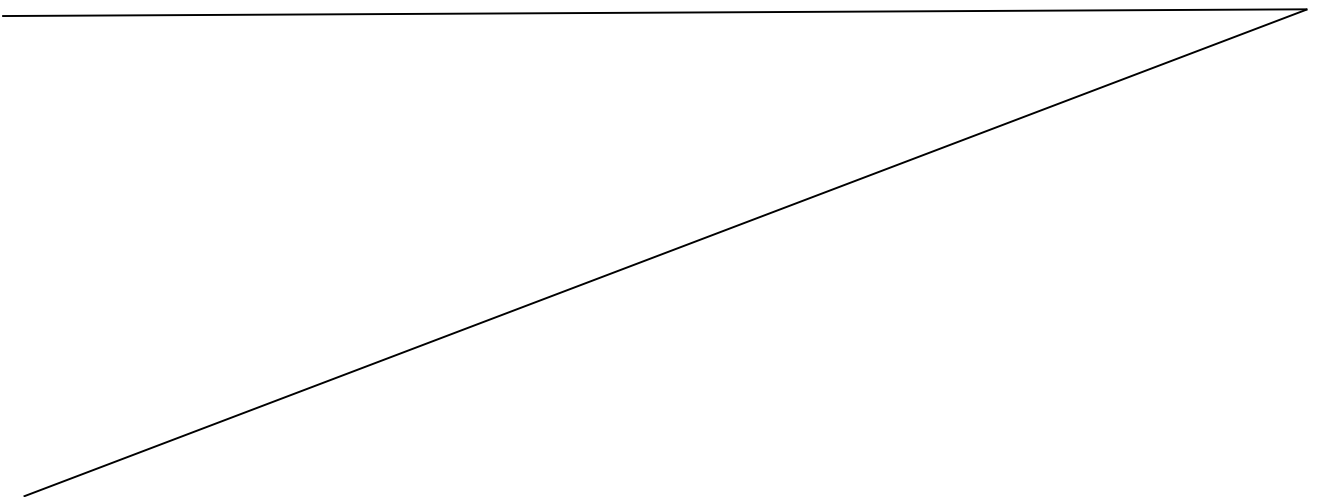



**Measured and calculated values of gaps around the perimeter of door leaves**

**Specimen No. 1**

Place of measurement "p"	Measured values [mm]			Mean [mm]	Maximum [mm]	Permitted gap size [mm]
	p1:	p2:	p3:			
Lock edge of door leaf	5,3	4,3	5,2	4,9	5,3	7,1
Upper edge of door leaf	p4:	p5:	p6:	3,9	4,0	6,0
Hinged edge of door leaf	p7:	p8:	p9:	4,2	4,4	6,3

Note: Bottom edge of door leaf is closed by means of drop down seal. Without gaps measurement on the bottom edge of door leaf.

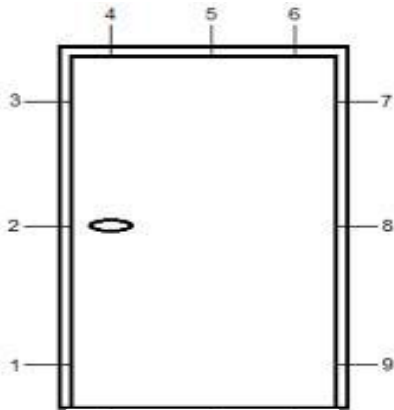

**Specimen No. 2**

Place of measurement "p"	Measured values [mm]			Mean [mm]	Maximum [mm]	Permitted gap size [mm]
	p1:	p2:	p3:			
Hinged edge of door leaf	4,6	4,0	4,7	4,4	4,7	6,6
Upper edge of door leaf	p4:	p5:	p6:	3,2	3,3	5,3
Lock edge of door leaf	p7:	p8:	p9:	4,0	4,2	6,1

Note: Bottom edge of door leaf is closed by means of drop down seal. Without gaps measurement on the bottom edge of door leaf.

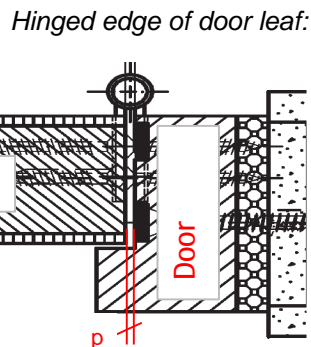
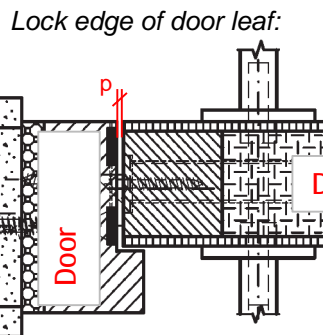
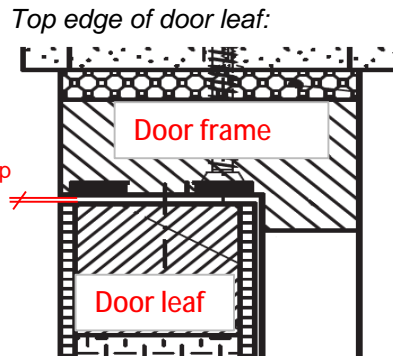
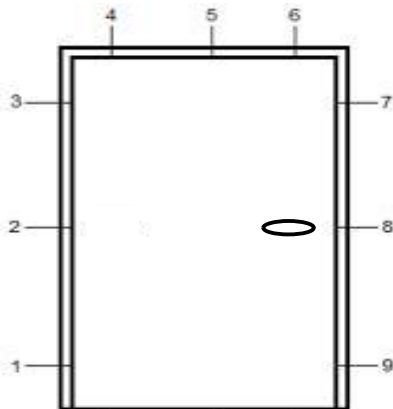





PHOTOS TAKEN DURING THE TEST



View of test specimen before test commencement



1<sup>st</sup> minute of the test



11<sup>th</sup> minute of the test





PHOTOS TAKEN DURING THE TEST



16<sup>th</sup> minute of the test



31<sup>st</sup> minute of the test



44<sup>th</sup> minute of the test

Sustained flaming in placed of the letter plate – **integrity failure**



PHOTOS TAKEN DURING THE TEST



50<sup>th</sup> minute of the test  
Sustained flaming on the vertical edge of letter plate – **integrity failure**



54<sup>th</sup> minute of the test



59<sup>th</sup> minute of the test





PHOTOS TAKEN DURING THE TEST



61<sup>st</sup> minute of the test

Termination of the test



View of the unexposed specimens face after the termination of the test

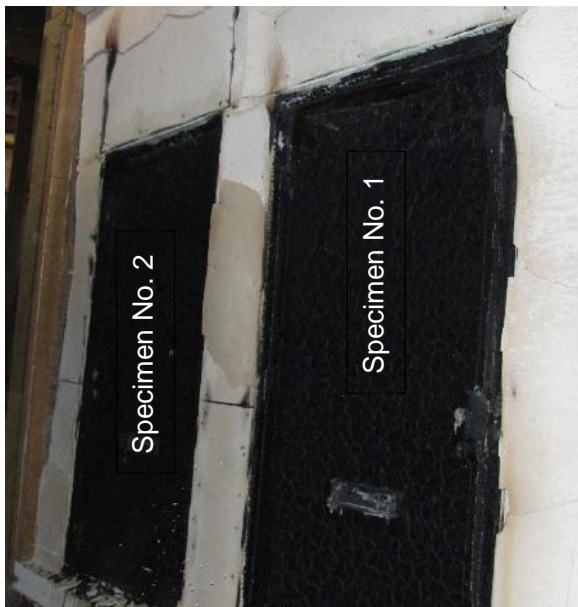

View of the exposed specimens face after the termination of the test



**DRAWINGS**

VIEW OF THE SPECIMEN No. 1  
FROM UNEXPOSED SIDE

HINGES TO THE FIRE

STANDARD FLEXIBLE SUPPORTING CONSTRUCTION  
ACC. TO EN 1363-1, 100 mm THICK

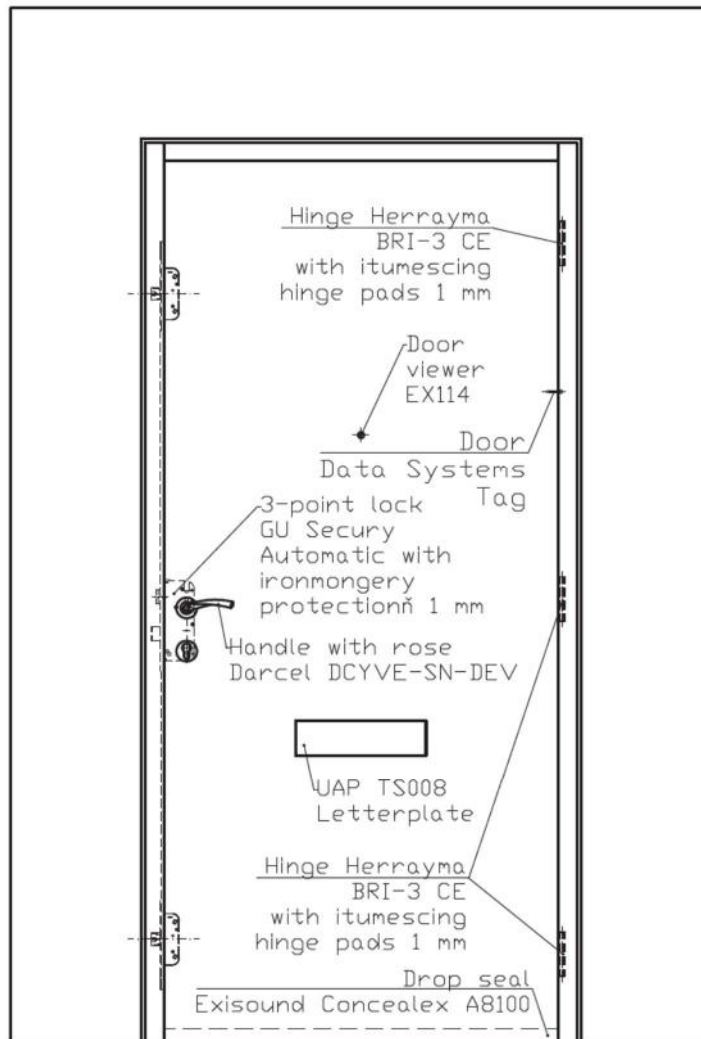

Specimen: Single leaf timber flush door Vllne Secure 30	Drawing No: 1
Project: PR-021-01	Specimen No.: 1
Drawing prepared by: AKURATNY FIRE CONSULTING	Drawing: front view





**DRAWINGS**

VIEW OF THE SPECIMEN No. 2  
FROM UNEXPOSED SIDE

HINGES FROM THE FIRE

STANDARD FLEXIBLE SUPPORTING CONSTRUCTION  
ACC. TO EN 1363-1, 100 mm THICK

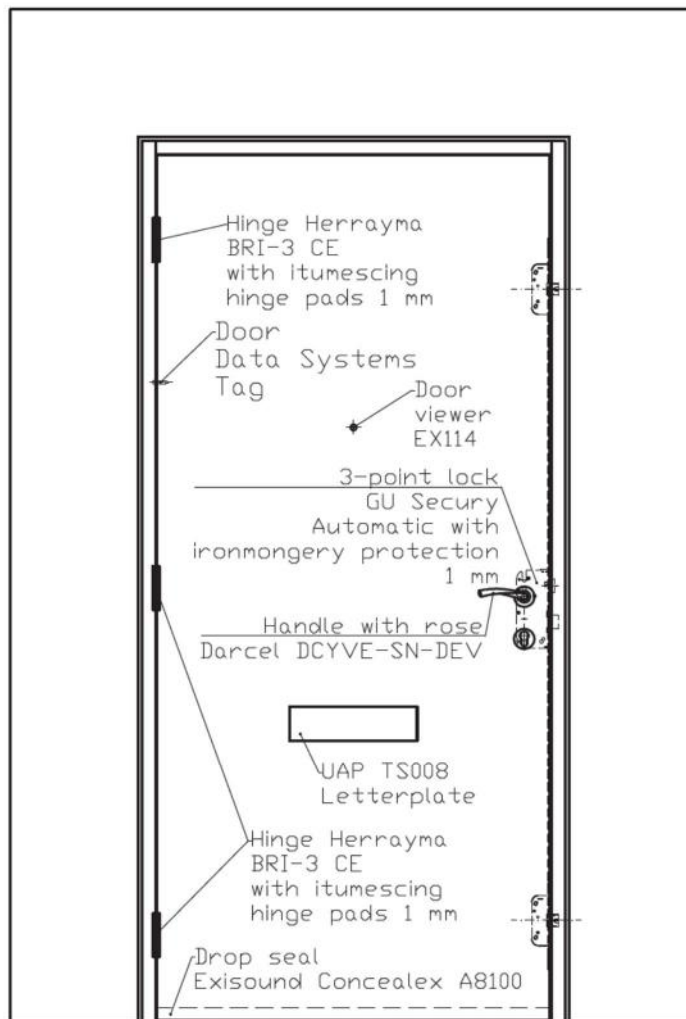

Specimen: Single leaf timber flush door Vline Secure 30	Drawing No: 2
Project: PR-021-01	Specimen No: 2
Drawing prepared by: AKURATNY FIRE CONSULTING	Drawing: front view



**DRAWINGS**

VIEW OF THE SPECIMEN No. 1  
FROM UNEXPOSED SIDE

CONSTRUCTION AND DIMENSIONS OF  
SPECIMEN No. 1 AND No. 2 ARE IDENTICAL

LEAVES THICKNESS: 52 mm

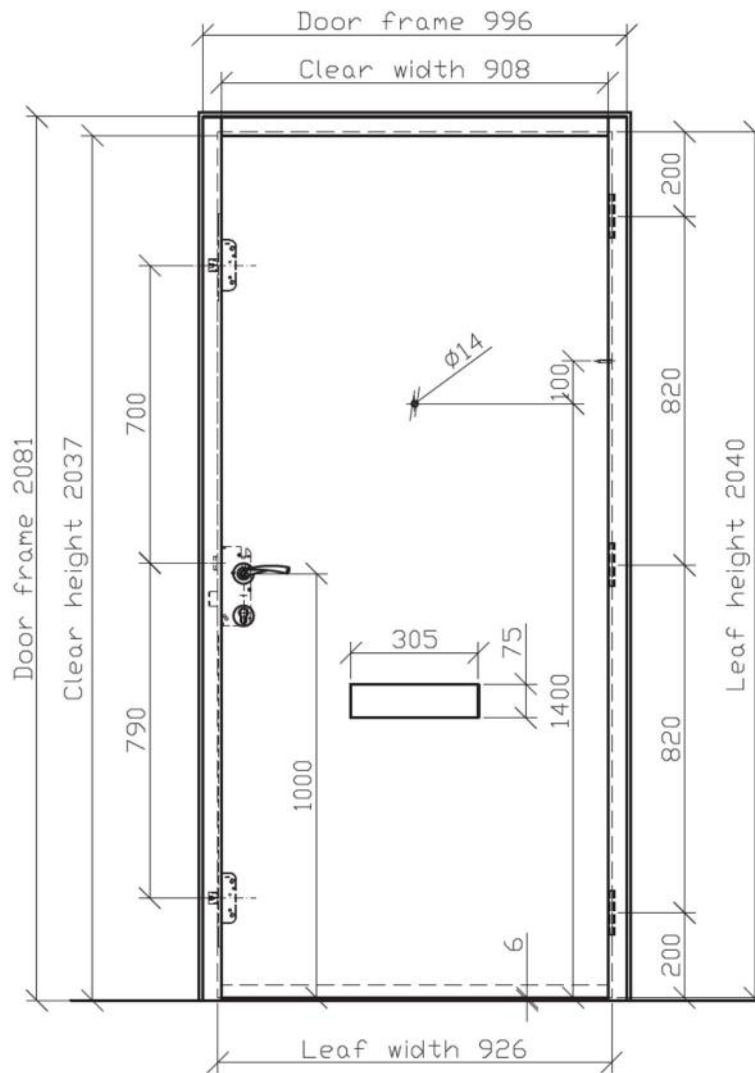

All dimensions in mm



Specimen: Single leaf timber flush door Vline Secure 30	Drawing No: 3
Project: PR-021-01	Specimen No: 1
Drawing prepared by: AKURATNY FIRE CONSULTING	Drawing: front view

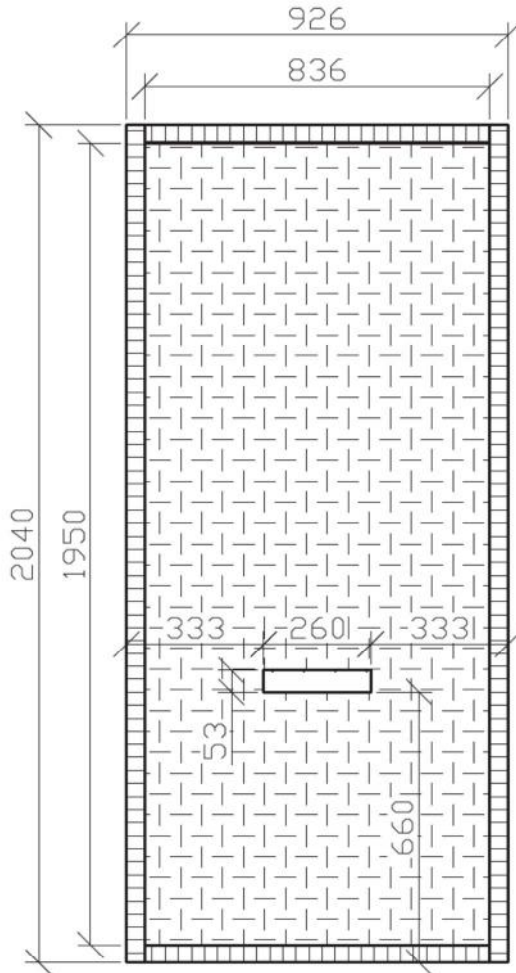

**DRAWINGS**

CONSTRUCTION OF DOOR LEAVES  
 Construction of specimen No. 1 and No. 2 is identical



-  SAPELE PROFILES  
 (45 x 44) mm (width x thickness)  
 density 640 kg.m<sup>-3</sup>
-  CORE:  
 Chipboard,  
 44 mm, density 600 kg/m<sup>3</sup>

SUBFACINGS on each door face: 4 mm HDF

all dimensions in mm

Specimen: Single leaf timber flush door Vline Secure 30	Drawing No: 4
Project: PR-021-01	Specimen No: 1
Drawing prepared by: AKURATNY FIRE CONSULTING	Drawing: leaves construction



**DRAWINGS**

CROSS-SECTIONS

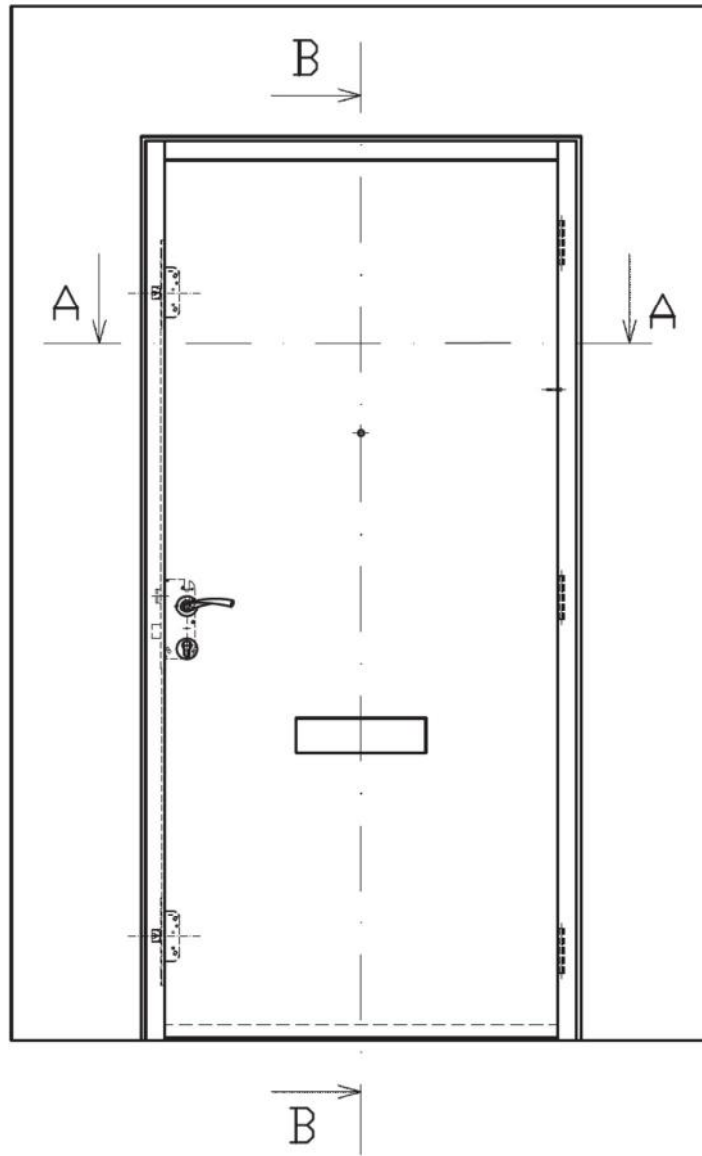

Specimen: Single leaf timber flush door Vline Secure 30	Drawing No: 5
Project: PR-021-01	Specimen No: 1
Drawing prepared by: AKURATNY FIRE CONSULTING	Drawing: cross-section



**DRAWINGS**

CROSS-SECTION A-A

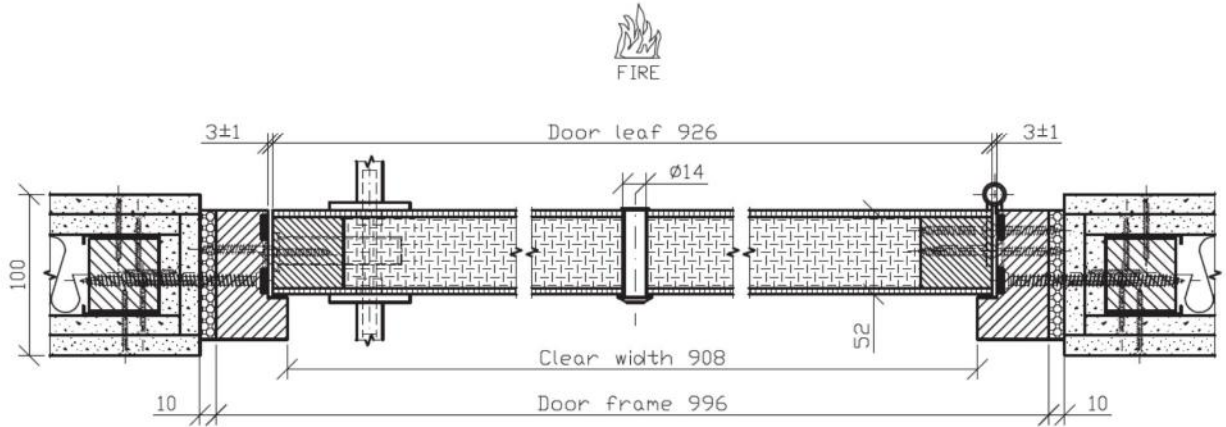

Door leaf details

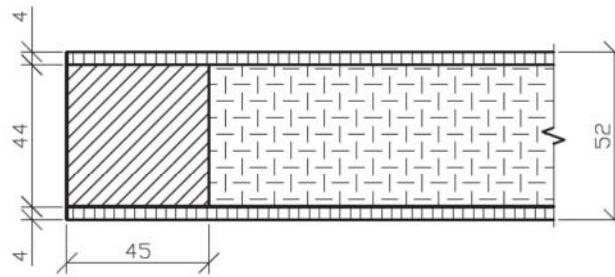

Door frame details

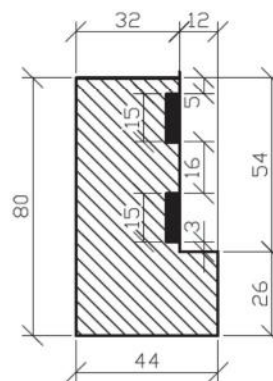

All dimensions in mm

Specimen: Single leaf timber flush door Vline Secure 30	Drawing No: 6
Project: PR-021-01	Specimen No: 1
Drawing prepared by: AKURATNY FIRE CONSULTING	Drawing: cross-sections A-A





**DRAWINGS**

CROSS-SECTION B-B

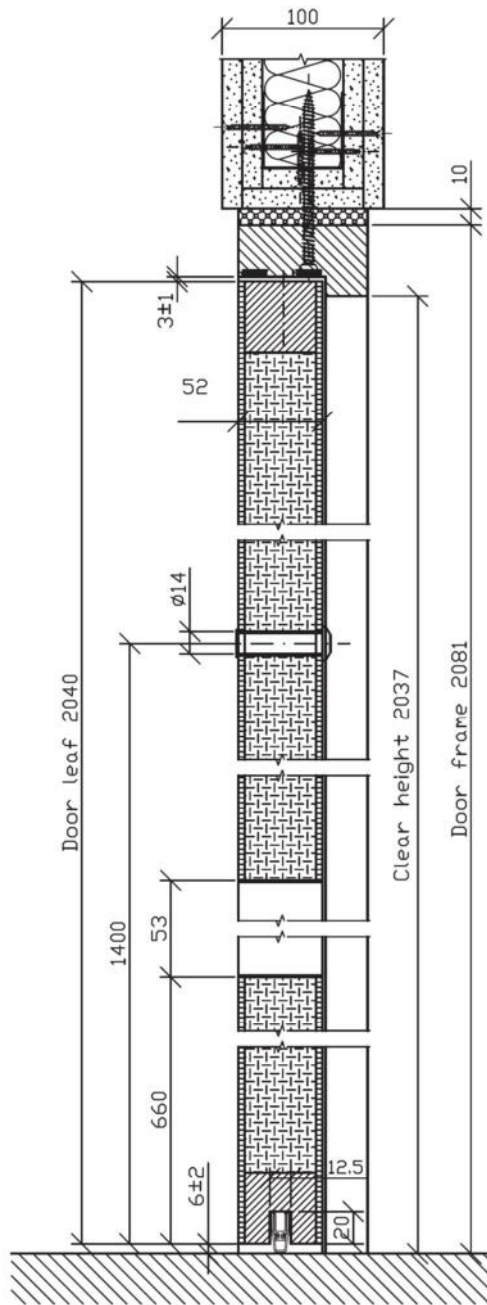

Door frame details

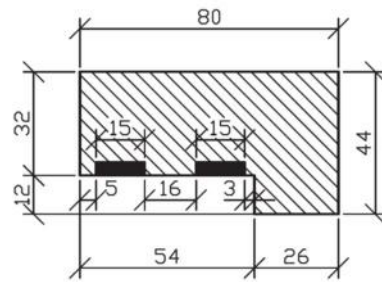

Door leaf details

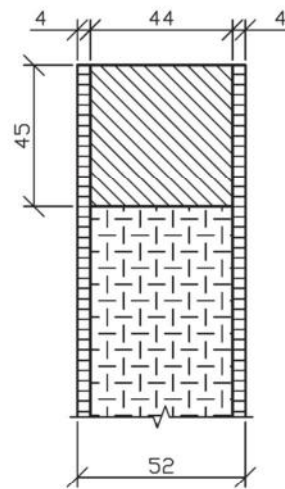

All dimensions in mm

Specimen: Single leaf timber flush door Vline Secure 30	Drawing No: 7
Project: PR-021-01	Specimen No.: 1
Drawing prepared by: AKURATNY FIRE CONSULTING	Drawing: cross-sections B-B



**DRAWINGS**

CROSS-SECTION A-A

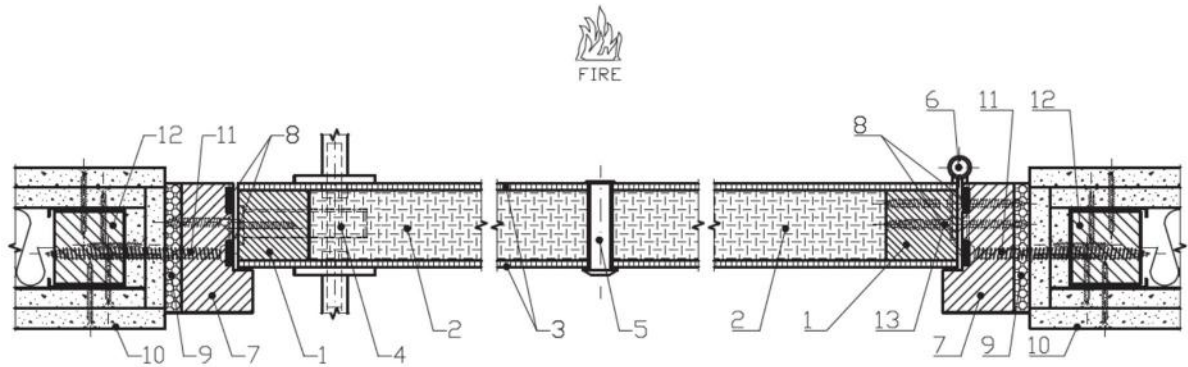

- 1 - Sapele profiles (45x44) mm;
- 2 - core: chipboard 44 mm thick;
- 3 - subfacing: HDF, 4 mm;
- 4 - 3-point lock GU Secure Automatic wrapped with lock protection with steel strike plates with graphite pad 1 mm and steel handle;
- 5 - door viewer EX114,  $\varnothing$  14 mm wrapped with intumescent tape;
- 6 - 3 x hinges Herrayma BRI-3 CE with graphite pad 1 mm;
- 7 - door frame made of Sapele profiles (44x80) mm;
- 8 - intumescent tape Pyrosist (15x4) mm;
- 9 - fire resistant PUR foam BLUE 60 FOAM;
- 10 - standard supporting construction acc. to EN 1363-1, 100 mm thick;
- 11 - steel screws ( $\varnothing$ 7,5x112) mm;
- 12 - spruce profile (43x45) mm;
- 13 - Door Data Systems Tag

Specimen: Single leaf timber flush door Vline Secure 30	Drawing No: 8
Project: PR-021-01	Specimen No: 1
Drawing prepared by: AKURATNY FIRE CONSULTING	Drawing: cross-sections A-A



**DRAWINGS**

CROSS-SECTION B-B

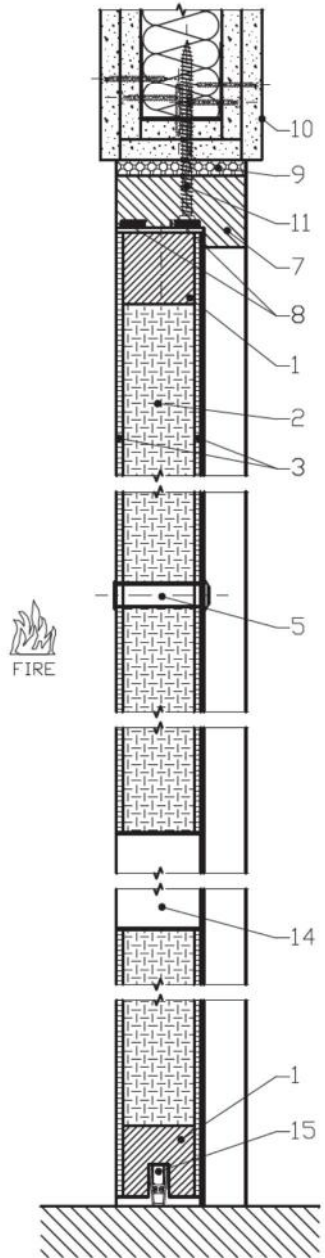

- 1 - Sapele profiles (45x44) mm;
- 2 - core: chipboard 44 mm thick;
- 3 - subfacing: HDF, 4 mm;
- 5 - door viewer EX114,  $\varnothing$  14 mm wrapped with intumescent tape;
- 7 - door frame made of Sapele profiles (44x80) mm;
- 8 - intumescent tape Pyrosist (15x4) mm;
- 9 - fire resistant PUR foam BLUE 60 FOAM;
- 10 - standard supporting construction acc. to EN 1363-1, 100 mm thick;
- 11 - steel screws ( $\varnothing$ 7,5x112) mm;
- 14 - letter plate UAP TS008;
- 15 - drop seal Exisound Concealex A8100;

Specimen: Single leaf timber flush door Vline Secure 30	Drawing No: 9
Project: PR-021-01	Specimen No: 1
Drawing prepared by: AKURATNY FIRE CONSULTING	Drawing: cross-sections B-B



**DRAWINGS**

POINTS OF FIXATION OF SPECIMENS  
TO STANDARD FLEXIBLE SUPPORTING CONSTRUCTION,  
100 mm THICK WITH STEEL SCREWS (ø7,5x112) mm

View from unexposed side of specimens

SPECIMEN No. 1  
Hinges to the fire

SPECIMEN No. 2  
Hinges from the fire

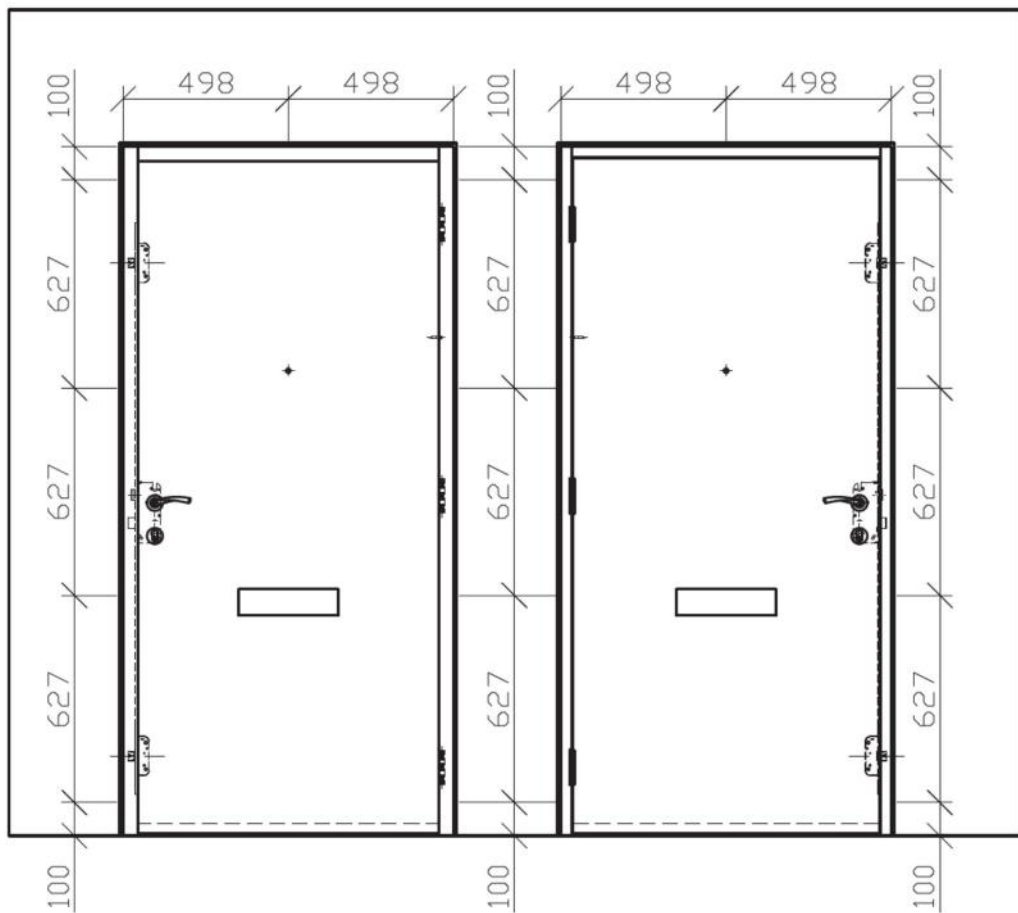

All dimensions in mm

Specimen: Single leaf timber flush door Vline Secure 30	Drawing No: 10
Project: PR-021-01	Specimen No: 1/2
Drawing prepared by: AKURATNY FIRE CONSULTING	Drawing: specimens fixation



## DRAWINGS

- 1 - Sapele profiles (45x44) mm, density 640 kg/m<sup>3</sup>, supplier: JAF Bulgaria
- 2 - core: chipboard 44 mm thick, supplier: UNILIN
- 3 - subfacing: HDF, 4 mm, density 700 kg/m<sup>3</sup>, supplier: Pflleiderer
- 4 - 3-point lock GU Secury Automatic wrapped with ExiFire lock protection with steel strike plates with graphite pad 1 mm, manufacturer: RAM Extrusion Ltd and steel handle DCYVE-SN-DEV, supplier of handle Darcel;
- 5 - door viewer type EX114, Ø 14 mm, supplier Exitex, wrapped with intumescent tape RAM Extrusion Ltd, 1 mm thick,
- 6 - 3 x hinges BRI-3 CE, manufacturer Herrayma with graphite pad 1 mm, manufacturer of pad RAM Extrusion;
- 7 - door frame made of Sapele profiles (44x80) mm, density 640 kg/m<sup>3</sup>, supplier: JAF Bulgaria
- 8 - intumescent tape Pyrosist 9010 (15x4) mm, manufacturer RAM Extrusion Ltd;
- 9 - fire resistant PUR foam BLUE 60 FOAM, manufacturer BLUE 60 UK Limited;
- 10 - standard supporting construction acc. to EN 1363-1, 100 mm thick
- 11 - steel screws (Ø7,5x112) mm
- 12 - spruce profile (43x45) mm
- 13 - Door Data Systems Tag, manufacturer Door Data Systems Ltd
- 14 - letter plate, UAP The Soterian TS008, supplier UAP Ltd
- 15 - drop seal, type Exisound Concealex A8100, manufacturer Exitex

Specimen: Single leaf timber flush door Vline Secure 30	Drawing No: 11
Project: PR-021-01	Specimen No: 1/2
Drawing prepared by: AKURATNY FIRE CONSULTING	Drawing: material list





DRAWINGS

# GU-Secury Automatic

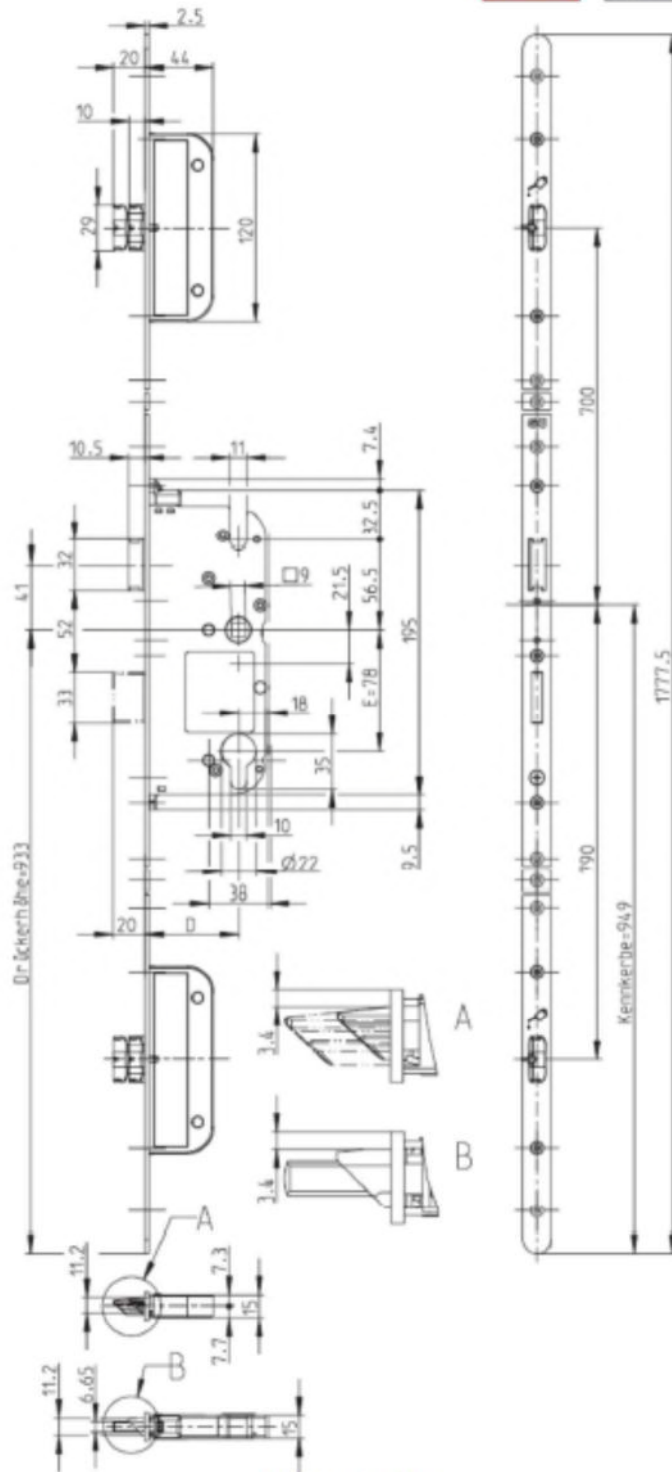

14.213., 14.214.



**DRAWINGS**

**CLASSIFICATION  
(Tested to EN 1906)**

**YVETTE – SN DEVELOPER**

Clause	Requirement Test	Result-Remark	Verdict
4.1	Coding System		-
4.1.2	Category of Use	1	-
4.1.3	Durability	6 – 200000 cycles	-
4.1.4	Door Mass	-	-
4.1.5	Fire Resistance	0	-
4.1.6	Safety	0	-
4.1.7	Corrosion Resistance	3	-
4.1.8	Security	0	-
4.1.9	Type of Operation	A	-
Finish: <b>Satin Nickel</b> Code: <b>DCYVE-SN DEV</b> Bar Code: <b>5060717410122</b> Lever Base Material: <b>Zinc Alloy/ Aluminium</b> Weight: <b>135g</b> Door Thickness: <b>35 – 45mm</b>			





DRAWINGS

BRI-3 (CE)

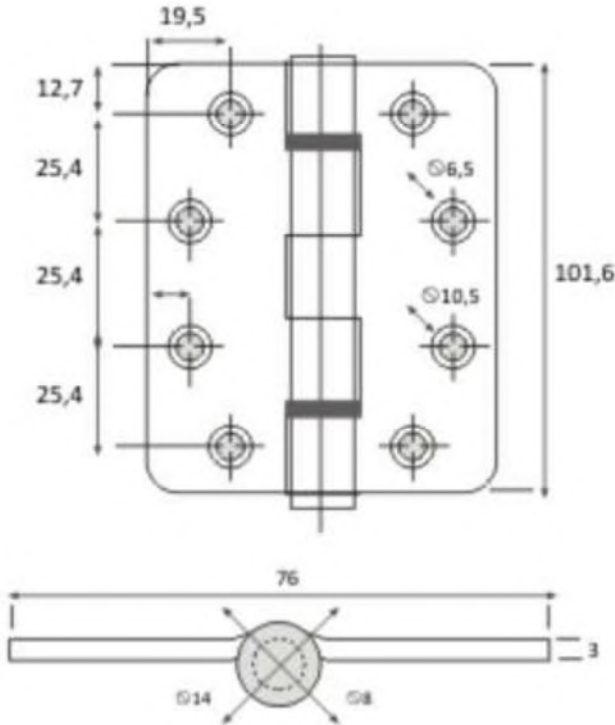



DRAWINGS





## Fire Rated Frame Foam

*Blue60™* is a specially formulated expanding foam that when used in conjunction with *Blue60™* fire rated packers gives up to 60 minutes fire protection to timber doorsets without the use of additional mastics or sealants.



<p>Fire Rated Packer 1mm x 15mm x 100mm Green</p>	<p>Fire Rated Packer 3mm x 15mm x 100mm White</p>	<p>Fire Rated Packer 5mm x 15mm x 100mm Blue</p>
---	---	--

**Key features**

- 30 & 60 minute fire tested to BS EN 1634-1 & BS 476 Part 22
- Test in full size single & double doorsets, not linear gaps
- No additional mastic or sealants required
- Acoustically tested to full doorset up to 43dB
- Tested in both metal and timber stud partitionings
- Tested with softwood, MDF & hardwood frame sections
- Tested with gaps between 7mm & 30mm
- Tested in a retro-fit scenario to allow use for rectification
- Blue in colour for identification purposes
- Fire rated packers must be used in conjunction with foam
- 1mm, 3mm & 5mm colour co-ordinated fire rated packers



## DRAWINGS



Technical specification sheet Door Data Systems Tag

Type. Referred Nail /

Dim's 36mm x 6mm

Counter sink head 1.5 mm x 9mm

Material Type.

ABS + Epoxy Resin

Frequency: 13.56Mhz

Door Data Systems uses 13.56Mhz nails.

(125Khz RFID are not suitable for NFC readers).



### Fixing The Data Tag into The Door Leaf.

Drill a hole measuring 6mm Diameter X 36mm

Drill a counter sink of 4mm to allow for a flush finish.

The tag will be a snug fit, the tag can be tapped with a mallet into the prepared hole.

There is no need to glue the tag into position.

The tag can be sunk below the finished door edge 3 – 5mm if required.





**DRAWINGS**



**WHAT IS TS008?**

TS008 has come in to effect that sets the advanced security requirements of letterplates. The updated door standard PAS24:2016, now requires that a door fitted with a letterplate has to have a letterplate that is tested to and meets the requirements of TS008. As well as covering key fishing, TS008 also covers preventing being able to unlock the door through the letterplate, whilst also allowing postal items to pass freely through it.



**THE SOTERIAN TS008 LETTERPLATE**

Named after the Goddess of Safety, the Soterian letterplate is stylish, streamlined and secure. It is the ultimate TS008 certified letterplate, made to protect and perfect your door. It is highly engineered with over 120 different processes in each letterplate, setting it apart from anything else currently on the market.

It has many features including:

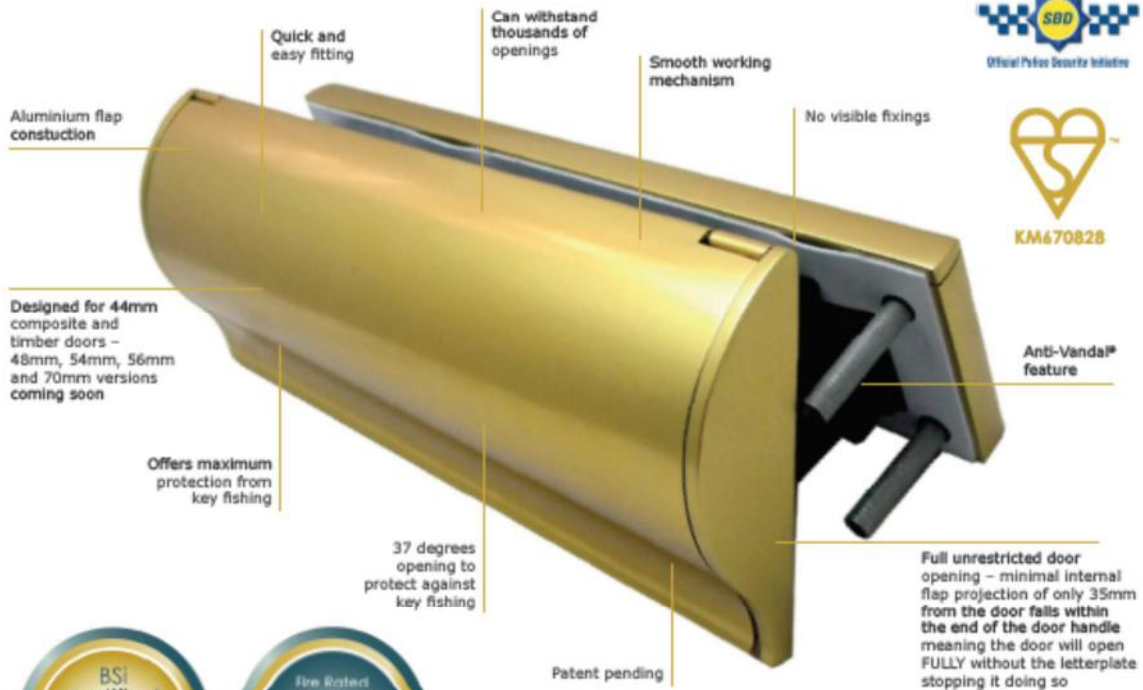

**MIX AND MATCH SOLUTION**

Our revolutionary mix and match solution gives you the freedom to choose what finish you want for the internal and external frame. Whether it is a black inner frame with a white outer frame, or a traditional gold inner flap and gold outer flap – the choice is yours! Choose from 6 different finishes chrome, gold anodised, silver anodised, polished silver, black and white.

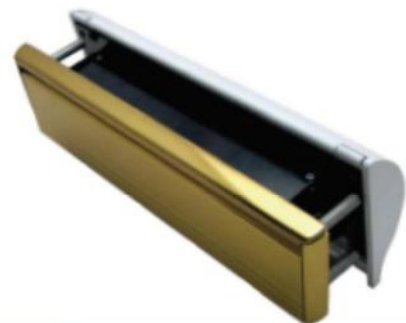

UAP Limited, Unit 1 Albert Close Trading Estate, Whitefield, Greater Manchester, United Kingdom, M45 8EH  
 Tel: 0161 796 7268 | Fax: 0161 796 7410 | Email: Sales@uapcorporate.com  
 www.uapcorporate.com



**DRAWINGS**



**AVAILABLE IN 5 FINISHES**

Finishes	Internal Frame Code	External Frame Code	Material Construction	Coating Guarantee
Chrome	TS008-INTERNAL-CHROME	TS008-EXTERNAL-CHROME	Zamak	5 Years Inland
Gold Anodised	TS008-INTERNAL-GOLD	TS008-EXTERNAL-GOLD	Aluminium	5 Years Inland
Silver Anodised	TS008-INTERNAL-SILVER	TS008-EXTERNAL-SILVER	Aluminium	5 Years Inland
Polished Silver	TS008-INTERNAL-PS	TS008-EXTERNAL-PS	Aluminium	5 Years Inland
Black	TS008-INTERNAL-BLACK	TS008-EXTERNAL-BLACK	Aluminium	5 Years Inland
White	TS008-INTERNAL-WHITE	TS008-EXTERNAL-WHITE	Aluminium	5 Years Inland

Coming Soon



**Internal Frame Sizes:**

Letterplate Length 300mm  
 Letterplate Height 115mm  
 Projection 35mm  
 Frame Material Aluminium

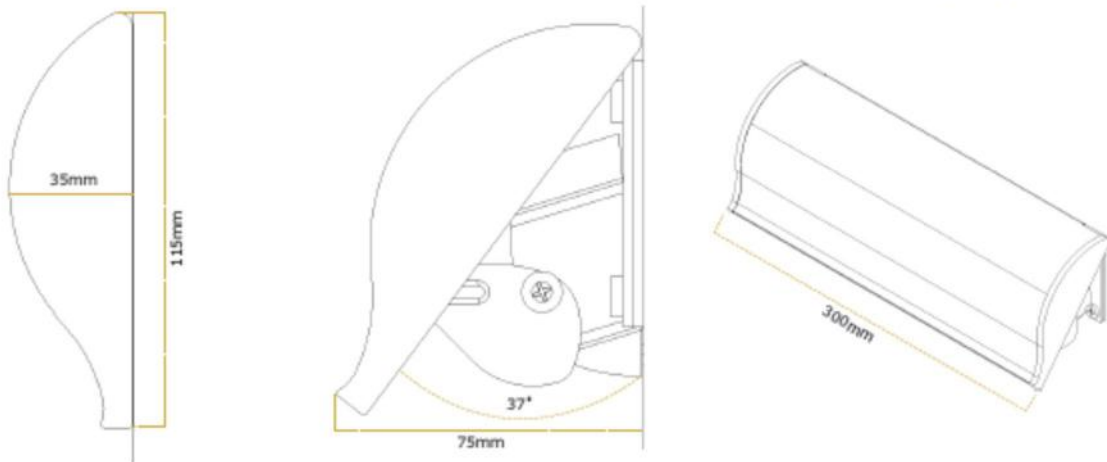
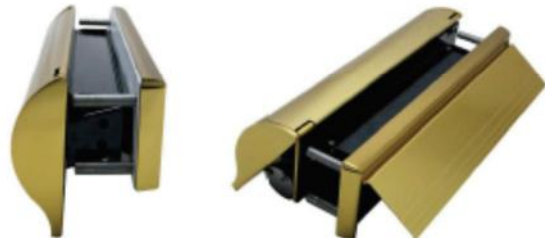

**External Frame Sizes:**

Distance Between Screw Holes 277mm  
 Letterplate Length 305mm  
 Letterplate Height 77mm  
 Frame Material Aluminium  
 Cavity Hole Size 53mm x 260mm

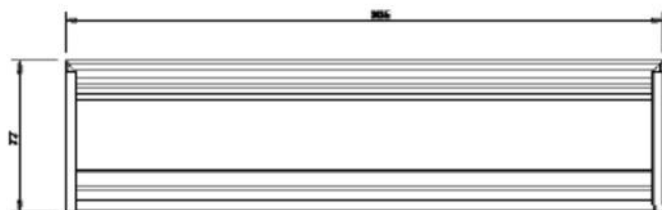

UAP Limited, Unit 1 Albert Close Trading Estate,  
 Whitefield, Greater Manchester, United Kingdom, M45 8EH  
 Tel: 0161 796 7268 | Fax: 0161 796 7410 | Email: Sales@uapcorporate.com  
 www.uapcorporate.com



**DRAWINGS**

# Concealex A8100

Ref: 1.50.0001

Application	Timber doors, aluminium doors, security doors and PVC doors
Maximum drop	14mm
Trimming lengths	Up to 150mm on the opposite side to the plunger (length 260mm cannot be shortened, 330mm can be shortened 50mm)
Fixing	With screws supplied
Adjustment	Standard Phillips Screwdriver
Self-levelling	Yes
Seal	Co-extruded tubular seal in self-extinguishing TPE
Fire Tested	For 30 & 60 minutes to BS EN 1634-1: 2014
Smoke Tested	to BS EN 1634-3: 2001
Acoustic Tested	up to 44DB to BS EN ISO 10140-2: 2010
In sizes	260mm, 330mm, 426mm, 526mm, 626mm, 726mm, 826mm, 914mm, 926mm, 1026mm, 1130mm, 1230mm, 1330mm and 1430mm

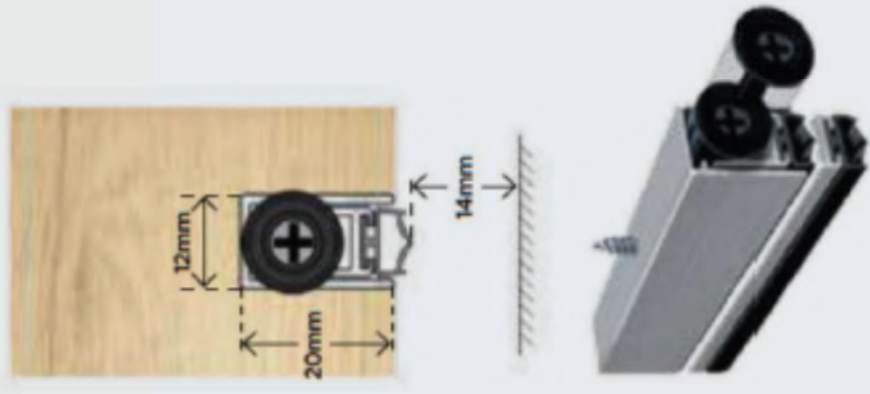





## 8. FINAL PROVISION

- § This report details the method of construction, the test conditions and results obtained when the specific element of construction described herein was following the procedure outlined in EN 1363-1, and where appropriate EN 1363-2. Any significant deviation with respect to size, constructional details, loads, stresses, edge or end conditions other than those allowed under the field of direct application in the relevant test method is not covered by this report.
- § Because of the nature of the fire resistance testing and consequent difficulty in quantifying the uncertainty of measurement of fire resistance, it is not possible to provide a stated degree of accuracy of the result.
- § The test results refer only to the tested subjects. This test report is not an approval of the tested product by the test laboratory or the accreditation body overseeing the laboratory's activities. The test was carried out on testing equipment that is the property of FIRES, s.r.o., Batizovce. Without the written permission of the test laboratory this test report may be copied and/or distributed only as the whole. Any modifications of the test report can be made only by the fire resistance test laboratory FIRES, s.r.o., Batizovce.

Approved by:

Ing. Marek Gorlický  
*Deputy Head of the testing laboratory*

Prepared by:

Bc. Matúš Korenko  
*Technician of the testing laboratory*

## 9. NORMATIVE REFERENCES

EN 1634-1: 2014+A1:2018	Fire resistance and smoke control tests for door, shutter and openable window assemblies and elements of building hardware. Part 1: Fire resistance tests for doors, shutters and openable windows
EN 1363-1: 2020	Fire resistance tests. Part 1: General requirements
EN 1363-2: 1999	Fire resistance tests. Part 2: Alternative and additional procedures
EN 1191: 2012	Windows and doors - Resistance to repeated opening and closing - Test method
EN 16034: 2014	Pedestrian doorsets, industrial, commercial, garage doors and openable windows. Product standard, performance characteristics. Fire resisting and/or smoke control characteristics

**THE END OF THE TEST REPORT**