

UL-EU CERTIFICATE

Certificate No. UL-EU-01058-CPR
Page 1/144
Date of Issue 2017-10-27
Revised 2022-07-29

Certificate Holder Tremco CPG UK Limited
Coupland Rd
Hindley Green
Wigan
WN2 4HT

Manufacturer A/017

Certified Product Type Fire Stop – Coated Board
Product Trade Name Nullifire FB750 Intubatt
Trademark N/A
Rating/Classification See Appendix

Harmonised Technical Specifications EAD 340454-00-1104, September 2017
Supporting Documentation ETA 21-0412, EC – CERTIFICATE OF CONSTANCY OF PERFORMANCE – 2531-CPR-CX010106, Classification Report No. 4790041433
Additional information Additional test evidence is held on file
Expiry date 2027/10/26



A blue ink signature of Chris Johnson.

Authorized Certification Decision Maker
Chris Johnson

This is to certify that representative samples of the Certified Product listed above have been investigated by Underwriters Laboratories to the Standard(s) indicated on this Certificate, in accordance with the UL Global Services Agreement and the UL-EU Mark Service Terms and Conditions ("Agreement"). The Certificate Holder is entitled to use the UL-EU Mark for the Certified Product listed on the certificate and manufactured at the production site(s) listed, in accordance with the terms of the Agreement. Only those products bearing the UL-EU Mark for Europe should be considered as being covered by UL's UL-EU Mark Service. This Certificate shall remain valid through the Expiration date, unless a Standard identified on this Certificate is amended or withdrawn prior to that date or there is a non-compliance with the Agreement.



Appendix UL-EU CERTIFICATE

Certificate No. UL-EU-01058-CPR
Page 2/144
Date of Issue 2017-10-27

This certificate relates to the use of Nullifire FB750 Intubatt for fire stopping where there are service penetrations through floors and walls. The detailed scope is given in pages 3 to 143 of this Certificate. This shows the thickness and acceptable dimensions, substrates and orientations required to provide fire resistance periods of up to 240 minutes for differing services and wall/floor constructions.

The product is certificated on the basis of:

1. ETA 21/0412
2. EC – CERTIFICATE OF CONFORMITY - 2531-CPR-CX010106
3. Inspection and surveillance of factory production control by UL
4. Fire resistance test data in accordance with EN 1366-3: 2009
5. Classification in accordance with EN 13501-2
6. Durability and Servicability as defined in EAD 340454-00-1104, September 2017

Nullifire FB750 Intubatt has been tested in accordance with the requirements of EAD 340454-00-1104, September 2017 to demonstrate its suitability for use in intended for use in internal conditions with humidity equal to or higher than 85% RH excluding temperatures below 0°C, without exposure to rain or UV.

These conditions are designated Z₁ in EAD 340454-00-1104, September 2017.



Appendix UL-EU CERTIFICATE

Certificate No. UL-EU-01058-CPR
 Page 3/144
 Date of Issue 2017-10-27

Product-type: Coated Board		Intended use: Penetration Seal
Assessment method	Essential characteristic	Product Performance
BWR 2 Safety in case of fire		
EN 13501-1	Reaction to fire	Class E
EN 13501-2	Resistance to fire	See pages 4 - 143
BWR 3 Hygiene, health and environment		
Declaration of manufacturer & EN 16516	Content, emission and/or release of dangerous substances	Use categories: IA3, S/W2 Declaration of manufacturer
EN 1026:2000	Air permeability (material property)	See page 4
EAD 350141-00-1106, Annex C & EN 12390-8	Water permeability (material property)	No performance determined
BWR 4 Safety in use		
EOTA TR 001:2003	Mechanical resistance and stability	No performance determined
EOTA TR 001:2003	Resistance to impact/movement	No performance determined
EOTA TR 001:2003 ISO 11600 & EAD 350141-00-1106, Clause 2.2.13	Adhesion	No performance determined
EAD 350141-00-1106, Clause 2.2.12	Durability	Type Z ₁
EAD 350141-00-1106, Clause 2.2.13	Movement capacity	No performance determined
EAD 350141-00-1106, Clause 2.2.14	Cycling of perimeter seals for curtain walls	No performance determined
EAD 350141-00-1106, Clause 2.2.15	Compression set	No performance determined
EAD 350141-00-1106, Clause 2.2.16	Linear expansion on setting	No performance determined
BWR 5 Protection against noise		
EN 10140-1,2,4,5/ EN ISO 717-1	Airborne sound insulation	See pages 5 - 7
BWR 6 Energy economy and heat retention		
EN 12664, EN 12667, EN 12939, EN ISO 8990, EN ISO 6946, EN ISO 10456	Thermal properties	No performance determined
EN ISO 12572, EN 12086, EN ISO 10456	Water vapour permeability	No performance determined



Appendix UL-EU CERTIFICATE



Certificate No. UL-EU-01058-CPR
 Page 4/144
 Date of Issue 2017-10-27

Air Permeability – Nullifire FB750			
Product tested	Nullifire FB750 with perimeter sealed with Nullifire FS702		
	Summary of testing procedure		Result
	Pressure (Pa)	Leakage (m³/h)	Leakage (m³/m²/h)
Results under negative chamber pressure	50	0.5	0.7
	100	0.5	0.7
	150	0.5	0.7
	200	0.5	0.7
	250	0.6	0.8
	300	0.6	0.8
	450	0.7	0.9
	500	1.0	1.4
	600	1.1	1.5
Results under positive chamber pressure	50	0.2	0.3
	100	0.4	0.5
	150	0.6	0.8
	200	0.6	0.8
	250	0.7	0.9
	300	0.8	1.1
	450	1.1	1.5
	500	1.1	1.5
	600	1.4	1.9



Appendix UL-EU CERTIFICATE

Certificate No. UL-EU-01058-CPR
 Page 5/144
 Date of Issue 2017-10-27

Airborne sound insulation– Nullifire FB750	
Configuration	Performance
<p>2No. Fire rated batts coated both sides with mastic spray grade, with 60mm cavity</p> 	<p>Dnew - 53 (-1;-5) dB Rw (1.87m2) - 40 (-4;-7) dB Rw (14.2m2) - 49 (-4;-7) dB</p>
<p>Fire rated batt Coated both sides with mastic spray grade</p> 	<p>Dnew - 31 (-1;-3) dB Rw (1.87m2) - 24 (-1;3) dB Rw (14.2m2) - 33 (-1;-3) dB</p>



Appendix UL-EU CERTIFICATE

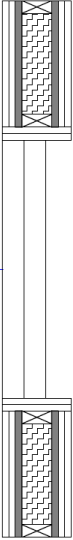
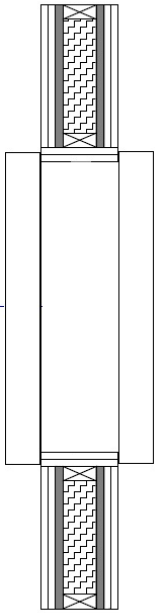

Certificate No. UL-EU-01058-CPR
 Page 6/144
 Date of Issue 2017-10-27

Configuration	Performance
 <p data-bbox="443 741 564 853">2No. Fire rated batts coated both sides with mastic spray grade, pushed together</p>	<p data-bbox="906 712 1219 801">Dnew - 39 (-1;-4) dB Rw (1.87m2) - 32 (-2;-4) dB Rw (14.2m2) - 42 (-2;-4) dB</p>
 <p data-bbox="419 1339 536 1440">2No. Fire rated batts Face fixed on source and receive room</p>	<p data-bbox="906 1305 1219 1395">Dnew - 39 (-1;-4) dB Rw (1.87m2) - 32 (-2;-4) dB Rw (14.2m2) - 42 (-2;-4) dB</p>



Appendix UL-EU CERTIFICATE

Certificate No. UL-EU-01058-CPR
 Page 7/144
 Date of Issue 2017-10-27

Configuration	Performance
 <p>15mm Soundbloc plasterboard placed over test aperture</p> <p>Fire rated batt Coated both sides with mastic spray grade</p>	<p>Dnew - 26 (0;-1) dB Rw (1.87m2) - 46 (-1;-6) dB Rw (14.2m2) - 55 (-1;-6) dB</p>
 <p>2 No. Fire rated batts coated both sides with mastic spray grade, with 60mm cavity</p> <p>100</p>	<p>Dnew - 50 (-1;-5) dB Rw (wall area) - 51 (-2;-6) dB Rw (specimen area 0.6 m²) - 38 (-1;-5) dB</p> <p>Dnew - 57 (-2;-9) dB Rw (wall area) - 58 (-1;-5) dB Rw (specimen area 0.3 m²) - 42 (-2;-9) dB</p>



Appendix UL-EU CERTIFICATE

Certificate No. UL-EU-01058-CPR
Page 8/144
Date of Issue 2017-10-27

Walls

Cables and Cable Carriers – Double Batt Pattress

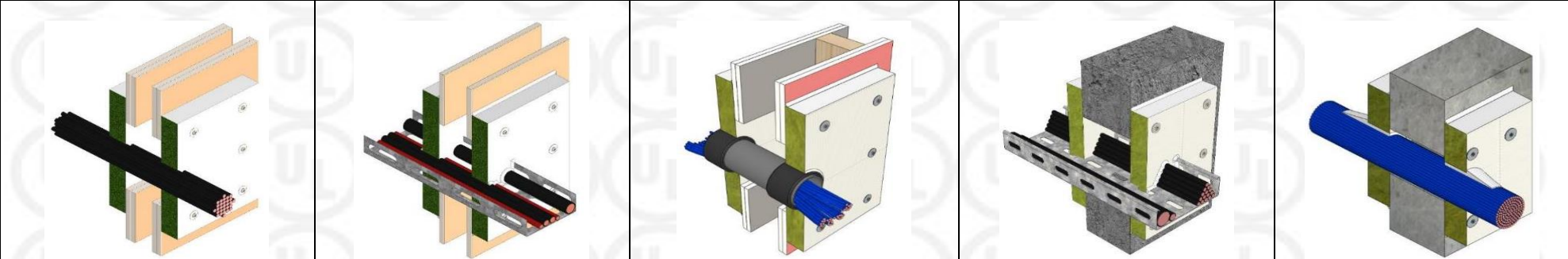
Cables, Metal Cable Trays, Trunking, Baskets and Ladders passing through Flexible and Rigid Walls as identified below, protected by double pattress (surface mounted) FB750 Intubatt seal, sealed with FS702 Intumastic or FS712 Intucoat.
Wall Details: Flexible or Rigid Walls including Concrete, Brick / Blockwork & AAC, of minimum thickness as identified below, and with performance classified to EN 13501-2.
Flexible Walls constructed from steel or timber faced studs with a minimum of 2 x 12.5mm EN 520 type F boards on each side of studs.
Maximum Opening size: 1100mm by 1100mm. Multiple openings must be separated by a minimum of 200mm for fire resistance requirements. Check separation requirements with the system owner of the supporting construction.
Installation Instructions: Boards surface mounted (pattress fit) on both sides of the wall with a minimum 75mm overlap around the opening. (Overlap on the lowest edge can be reduced to 30mm in the event of an obstruction preventing the 75mm overlap). The overlap should be bonded with a 10mm bead of FS702 Intumastic placed 20-60mm from the board edges, and additionally mechanically restrained using 75mm steel screws with a 25mm washer at maximum 300mm centres, 10-65mm from the board perimeter and no more than 50mm from a board joint. A low torque setting should be used to ensure that the embedment of fixing into the board does not exceed 15mm. The fixings may be left exposed or covered using FS702 Intumastic. The FB750 Intubatt should be installed in as few cut pieces as possible. All joints are to be bonded using FS712 Intucoat to full width of the FB750 Intubatt or FS702 Intumastic applied as a 10mm bead along the full-length joint centre line. FS702 Intumastic should be used to point all service and substrate interfaces, to a minimum of a 6mm bead. Apertures for penetrating services are to be tightly fitted and sealed. Imperfections should be filled with FS702 Intumastic to the full depth of the FB750 Intubatt. Service openings should be cut no more than 15mm away from non-combustible services, and/or, openings should be cut to suit the requirements of any additional required Nullifire product, if the service type is combustible or insulated CS or LS. External sides of the Board may be required to be coated for aesthetic reasons or to prevent fibre migration. (In situations where the required overlap cannot be achieved due to a perpendicular fire resisting wall / soffit, it is possible to reduce the overlap, down to as low as 0mm, provided the board edge is bonded to the adjoining compartment using a 10mm bead of FS702 Intumastic, and subsequently pointed to all mated edges)

Form-ULID-006104 (DCS:27-CP-F0855) 5.0



Appendix UL-EU CERTIFICATE

Certificate No. UL-EU-01058-CPR
 Page 9/144
 Date of Issue 2017-10-27

Service	Integrity	Integrity & Insulation	Rigid Wall Thickness (mm)					Flexible Wall Thickness (mm)		Additional Requirements (Both Sides)
	E (mins)	EI (mins)	≥ 215	≥ 150	≥ 130	≥ 110	≥ 100	≥ 130	≥ 100	
Metal Cable Trays, Trunking, Baskets and Ladder ≤ 450mm width	120	120	✓	✓	✓			✓		200mm extension of 1 layer of FI025 Intuflex, taped with aluminium foil (min 30 micron), abutting FB750 Intubatt
Metal Cable Trays, Trunking, Baskets and Ladder ≤ 450mm width	120	120	✓	✓	✓			✓		200mm extension of 1 layer of FI025 Intuflex, taped with aluminium foil (min 30 micron), abutting FB750 Intubatt
Metal Cable Trays, Trunking, Baskets and Ladder ≤ 225mm width	120	120	✓	✓	✓			✓		-
Metal Cable Trays, Trunking, Baskets and Ladder ≤ 150mm width	120	120	✓	✓	✓	✓				-
Metal Cable Trays, Trunking, Baskets and Ladder ≤ 450mm width	120	120	✓	✓						25mm annulus of FS709 HP Intumescent Sealant, 25mm depth (using FB750 as backer)
Steel trunking ≤ 50mm x 50mm x 1mm	120	120	✓	✓	✓	✓	✓	✓	✓	FP333 Trunking Infill 29 x 47 x 333mm one side only (either side) or central
Bundle of ≤ 37 twin & earth cables, each ≤ 17mm diameter	240	240	✓	✓						200mm extension of 1 layer of FI025 Intuflex, taped with aluminium foil (min 30 micron), abutting FB750 Intubatt
≤ 10 communication cables, each ≤ 7mm diameter within a ≤ 100mm x 100mm x 1.2mm steel trunking	120	120	✓	✓	✓	✓	✓			-
≤ 4 twin and earth cables, each ≤ 17mm diameter within a ≤ 100mm x 100mm x 1.2mm steel trunking	120	120	✓	✓	✓	✓	✓			-
≤ 15 Cat 5 Ethernet cables, each ≤ 6mm diameter, within a ≤ 50mm x 50mm x 1mm steel trunking	120	120	✓	✓	✓	✓	✓	✓	✓	2 layers of FP333 Trunking Infill 47 x 29 x 333mm one side only (either side) or central, 50mm minimum extension into seal
16 to 45 Cat 5 Ethernet cables, each ≤ 6mm diameter, within a ≤ 50mm x 50mm x 1mm steel trunking	120	120	✓	✓	✓	✓	✓	✓	✓	1 layer of FP333 Trunking Infill 47 x 29 x 333mm one side only (either side) or central, 50mm minimum extension into seal



Appendix UL-EU CERTIFICATE

Certificate No. UL-EU-01058-CPR
 Page 10/144
 Date of Issue 2017-10-27

Service	Integrity	Integrity & Insulation	Rigid Wall Thickness (mm)					Flexible Wall Thickness (mm)		Additional Requirements (Both Sides)
	E (mins)	EI (mins)	≥ 215	≥ 150	≥ 130	≥ 110	≥ 100	≥ 130	≥ 100	
≤ 24 Cat 5 Ethernet cables, each ≤ 6mm diameter, within a ≤ 100mm x 100mm x 1mm steel trunking	120	120	✓	✓	✓	✓	✓	✓	✓	3 layers of FP333 Trunking Infill 97 x 29 x 333mm one side only (either side) or central, 50mm minimum extension into seal
25 to 90 Cat 5 Ethernet cables, each ≤ 6mm diameter, within a ≤ 100mm x 100mm x 1mm steel trunking	120	120	✓	✓	✓	✓	✓	✓	✓	2 layers of FP333 Trunking Infill 97 x 29 x 333mm one side only (either side) or central, 50mm minimum extension into seal
91 to 158 Cat 5 Ethernet cables, each ≤ 6mm diameter, within a ≤ 100mm x 100mm x 1mm steel trunking	120	120	✓	✓	✓	✓	✓	✓	✓	1 layer of FP333 Trunking Infill 97 x 29 x 333mm one side only (either side) or central, 50mm minimum extension into seal
≤ 24 Cat 5 Ethernet cables, each ≤ 6mm diameter, ≤ 150mm x 100mm x 1mm steel trunking	120	120	✓	✓	✓	✓	✓	✓	✓	3 layers of FP333 Trunking Infill 147 x 29 x 333mm one side only (either side) or central, 50mm minimum extension into seal
25 to 90 Cat 5 Ethernet cables, each ≤ 6mm diameter, within a ≤ 150mm x 100mm x 1mm steel trunking	120	120	✓	✓	✓	✓	✓	✓	✓	2 layers of FP333 Trunking Infill 147 x 29 x 333mm one side only (either side) or central, 50mm minimum extension into seal
91 to 158 Cat 5 Ethernet cables, each ≤ 6mm diameter, within a ≤ 150mm x 100 mm x 1mm steel trunking	120	120	✓	✓	✓	✓	✓	✓	✓	1 layer of FP333 Trunking Infill 147 x 29 x 333mm one side only (either side) or central, 50mm minimum extension into seal
≤ 24 Cat 5 Ethernet cables, each ≤ 6mm diameter, within a ≤ 150mm x 100mm x 1mm steel trunking	120	120	✓	✓	✓	✓	✓	✓	✓	3 layers of FP333 Trunking Infill 147 x 29 x 333mm one side only (either side) or central, 50mm minimum extension into seal
≤ 2 G2 cables, each ≤ 20mm diameter, within a ≤ 41mm x 41mm x 2.5mm steel trunking with PVC lid	120	120	✓	✓	✓	✓	✓	✓	✓	1 layer of FP333 Trunking Infill 47 x 29 x 333mm one side only (either side) or central, 50mm minimum extension into seal
Bundle of ≤ 10 Communication cables, each ≤ 7mm diameter	120	120	✓	✓	✓	✓	✓			-
Bundle of ≤ 4 Twin & earth cables, each ≤ 17mm	120	120	✓	✓	✓	✓	✓			-
Bundle of ≤ 20 Cat 5 Ethernet cables, each ≤ 6mm diameter within a Ribbed Nylon Copex combustible conduit ≤ 55mm x (0.5 to 1.2mm)	120	120	✓	✓	✓	✓	✓	✓	✓	1 layer of FP302 Intustrap, sealed within FB750 Intubatt with FS702 Intumastic



Appendix UL-EU CERTIFICATE

Certificate No. UL-EU-01058-CPR
 Page 11/144
 Date of Issue 2017-10-27

Service	Integrity	Integrity & Insulation	Rigid Wall Thickness (mm)					Flexible Wall Thickness (mm)		Additional Requirements (Both Sides)
	E (mins)	EI (mins)	≥ 215	≥ 150	≥ 130	≥ 110	≥ 100	≥ 130	≥ 100	
1 Ethernet Cat 5 cable, ≤ 6mm diameter, within a PEX multilayer conduit ≤ 28mm x 2.6mm	120	120	✓	✓	✓	✓	✓	✓	✓	1 layer of FP302 Intustrap, sealed within FB750 Intubatt with FS702 Intumastic
1 Ethernet Cat 5 cable ≤ 6mm diameter, 1 TV coaxial cable ≤ 10mm diameter, 1 fibre optic cable ≤ 12mm diameter within a PEX multilayer conduit ≤ 28mm x 2.6mm	120	120	✓	✓	✓	✓	✓	✓	✓	1 layer of FP302 Intustrap, sealed within FB750 Intubatt with FS702 Intumastic
1 Fibre optic cable, ≤ 12mm diameter within a PEX multilayer conduit ≤ 28mm x 2.6mm	120	120	✓	✓	✓	✓	✓	✓	✓	1 layer of FP302 Intustrap, sealed within FB750 Intubatt with FS702 Intumastic
1 TV coaxial cable ≤ 10mm diameter within a PEX multilayer conduit ≤ 28mm x 2.6mm	120	120	✓	✓	✓	✓	✓	✓	✓	1 layer of FP302 Intustrap, sealed within FB750 Intubatt with FS702 Intumastic
Bundle of ≤ 10 A1 cables, each ≤ 12mm	120	120	✓	✓	✓			✓		200mm extension of 1 layer of FI025 Intuflex, taped with aluminium foil (min 30 micron), abutting FB750 Intubatt
Bundle of ≤ 10 A2 cables, each ≤ 12mm	120	120	✓	✓	✓			✓		200mm extension of 1 layer of FI025 Intuflex, taped with aluminium foil (min 30 micron), abutting FB750 Intubatt
Bundle of ≤ 10 A3 cables, each ≤ 12mm diameter	120	120	✓	✓	✓			✓		200mm extension of 1 layer of FI025 Intuflex, taped with aluminium foil (min 30 micron), abutting FB750 Intubatt
≤ 2 type B cables, each ≤ 19mm diameter	120	120	✓	✓	✓			✓		200mm extension of 1 layer of FI025 Intuflex, taped with aluminium foil (min 30 micron), abutting FB750 Intubatt
1 type C1 cable ≤ 41mm diameter	120	120	✓	✓	✓			✓		200mm extension of 1 layer of FI025 Intuflex, taped with aluminium foil (min 30 micron), abutting FB750 Intubatt
1 type C2 cable ≤ 50mm diameter	120	120	✓	✓	✓			✓		200mm extension of 1 layer of FI025 Intuflex, taped with aluminium foil (min 30 micron), abutting FB750 Intubatt
1 type C2 cable ≤ 50mm diameter	120	120	✓	✓	✓			✓		200mm extension of 1 layer of FI025 Intuflex, taped with aluminium foil (min 30 micron), abutting FB750 Intubatt



Appendix UL-EU CERTIFICATE

Certificate No. UL-EU-01058-CPR
 Page 12/144
 Date of Issue 2017-10-27

Service	Integrity	Integrity & Insulation	Rigid Wall Thickness (mm)					Flexible Wall Thickness (mm)		Additional Requirements (Both Sides)
	E (mins)	EI (mins)	≥ 215	≥ 150	≥ 130	≥ 110	≥ 100	≥ 130	≥ 100	
1 type C3 cable ≤ 37mm diameter	120	120	✓	✓	✓			✓		200mm extension of 1 layer of FI025 Intuflex, taped with aluminium foil (min 30 micron), abutting FB750 Intubatt
1 type D1 cable ≤ 55mm diameter	120	120	✓	✓	✓			✓		200mm extension of 1 layer of FI025 Intuflex, taped with aluminium foil (min 30 micron), abutting FB750 Intubatt
1 type D2 cable ≤ 65mm diameter	120	120	✓	✓	✓			✓		200mm extension of 1 layer of FI025 Intuflex, taped with aluminium foil (min 30 micron), abutting FB750 Intubatt
1 type D3 cable ≤ 52.5mm diameter	120	120	✓	✓	✓			✓		200mm extension of 1 layer of FI025 Intuflex, taped with aluminium foil (min 30 micron), abutting FB750 Intubatt
≤ 2 type E cables, each ≤ 25mm diameter	120	120	✓	✓	✓			✓		200mm extension of 1 layer of FI025 Intuflex, taped with aluminium foil (min 30 micron), abutting FB750 Intubatt
Bundle of ≤ 100mm diameter type F cables, each ≤ 13mm diameter	120	120	✓	✓	✓			✓		200mm extension of 1 layer of FI025 Intuflex, taped with aluminium foil (min 30 micron), abutting FB750 Intubatt
1 type D3 cable ≤ 52.5mm diameter	120	120	✓	✓	✓			✓		-
1 type G1 cable ≤ 15mm diameter	120	120	✓	✓	✓			✓		200mm extension of 1 layer of FI025 Intuflex, taped with aluminium foil (min 30 micron), abutting FB750 Intubatt
1 type G2 cable ≤ 20mm diameter	120	120	✓	✓	✓			✓		200mm extension of 1 layer of FI025 Intuflex, taped with aluminium foil (min 30 micron), abutting FB750 Intubatt
Bundle of ≤ 12 twin & earth cables - each ≤ 17mm diameter	120	120	✓	✓	✓	✓	✓			Cone (60mm circumference, 60mm along the cable) of FS702 Intumastic to outside of FB750 Intubatt seal
Bundle of ≤ 3 fire alarm (gold) cables, each ≤ 8mm diameter	120	120	✓	✓	✓	✓	✓			Cone (60mm circumference, 60mm along the cable) of FS702 Intumastic to outside of FB750 Intubatt seal



Appendix UL-EU CERTIFICATE

Certificate No. UL-EU-01058-CPR
 Page 13/144
 Date of Issue 2017-10-27

Service	Integrity	Integrity & Insulation	Rigid Wall Thickness (mm)					Flexible Wall Thickness (mm)		Additional Requirements (Both Sides)
	E (mins)	EI (mins)	≥ 215	≥ 150	≥ 130	≥ 110	≥ 100	≥ 130	≥ 100	
1 TV coaxial cable ≤ 10mm diameter	120	120	✓	✓	✓	✓	✓			Cone (60mm circumference, 60mm along the cable) of FS702 Intumastic to outside of FB750 Intubatt seal
Bundle of ≤ 9 TV Coaxial cables, each ≤ 10mm diameter, in a ≤ 55mm x 3.2mm ABS Conduit	120	120	✓	✓						2 layers of FP302 Intustrap, sealed within FB750 Intubatt with FS702 Intumastic
Bundle of ≤ 3 Fire alarm cables, each ≤ 10mm diameter, in a ≤ 55mm x 3.2mm ABS Conduit	120	120	✓	✓						2 layers of FP302 Intustrap, sealed within FB750 Intubatt with FS702 Intumastic
Bundle of ≤ 12 Fibre optic cables, each ≤ 8mm diameter, in a ≤ 55mm x 3.2mm ABS Conduit	120	120	✓	✓						1 layer of FP302 Intustrap, sealed within FB750 Intubatt with FS702 Intumastic
Bundle of ≤ 20 Audiovisual cables, each ≤ 10mm diameter within an ≤ 80mm x 3.2mm PVC Conduit	120	120	✓	✓						2 layers of FP302 Intustrap, sealed within FB750 Intubatt with FS702 Intumastic
Bundle of ≤ 65 different cables within an ≤ 80mm x 3.2mm PVC Conduit: ≤ 20 Audiovisual cables, each ≤ 10mm diameter ≤ 17 Ethernet Cat 5 cables, each ≤ 6mm diameter ≤ 17 Telecoms cables, each ≤ 5mm diameter ≤ 7 Fibre optic cables, each ≤ 12mm diameter ≤ 4 twin & earth cables, each ≤ 17mm diameter	120	120	✓	✓						2 layers of FP302 Intustrap, sealed within FB750 Intubatt with FS702 Intumastic
Bundle of ≤ 17 Ethernet Cat5 cables, each ≤ 6mm diameter within an ≤ 80mm x 3.2mm PVC Conduit	120	120	✓	✓						2 layers of FP302 Intustrap, sealed within FB750 Intubatt with FS702 Intumastic
Bundle of ≤ 7 Fibre optic cables, each ≤ 12mm diameter within an ≤ 80mm x 3.2mm PVC Conduit	120	120	✓	✓						2 layers of FP302 Intustrap, sealed within FB750 Intubatt with FS702 Intumastic
Bundle of ≤ 17 telecom cables, each ≤ 5mm diameter within an ≤ 80mm x 3.2mm PVC Conduit	120	120	✓	✓						2 layers of FP302 Intustrap, sealed within FB750 Intubatt with FS702 Intumastic



Appendix UL-EU CERTIFICATE

Certificate No. UL-EU-01058-CPR
 Page 14/144
 Date of Issue 2017-10-27

Service	Integrity	Integrity & Insulation	Rigid Wall Thickness (mm)					Flexible Wall Thickness (mm)		Additional Requirements (Both Sides)
	E (mins)	EI (mins)	≥ 215	≥ 150	≥ 130	≥ 110	≥ 100	≥ 130	≥ 100	
Bundle of ≤ 4 twin and earth cables, each ≤ 17mm diameter within an ≤ 80mm x 3.2mm PVC Conduit	120	120	✓	✓						2 layers of FP302 Intustrap, sealed within FB750 Intubatt with FS702 Intumastic
Bundle of ≤ 12 Fibre optic cables, each ≤ 8mm diameter	120	120	✓	✓						1 layer of FP302 Intustrap, sealed within FB750 Intubatt with FS702 Intumastic
Bundle of ≤ 100mm Diameter A1 cable, each ≤ 12mm diameter	120	120	✓	✓						≤ 85mm high FS709 HP Intumescent Sealant, 50mm depth
1 type C2 cable ≤ 50mm diameter	120	120	✓	✓						≤ 85mm high FS709 HP Intumescent Sealant, 50mm depth
1 type D2 cable ≤ 65mm diameter	120	120	✓	✓						≤ 85mm high FS709 HP Intumescent Sealant, 50mm depth
Bundle of ≤ 3 Fire alarm cables, each ≤ 10mm diameter	120	120	✓	✓						≤ 85mm high FS709 HP Intumescent Sealant, 50mm depth
Bundle of ≤ 3 TV Coaxial cables, each ≤ 12mm	120	120	✓	✓						25mm annulus of FS709 HP Intumescent Sealant, 25mm depth (using FB750 as backer)
1 type G2 cable ≤ 20mm diameter	120	90	✓	✓	✓	✓	✓			Cone (100mm circumference, 60mm along the cable) of FS702 Intumastic to outside of FB750 Intubatt seal
Bundle of ≤ 100mm diameter A1 cables, each ≤ 12mm diameter	60	60	✓	✓						-
≤ 4 type B cables, each ≤ 19mm diameter	60	60	✓	✓						-
1 type C2 cable ≤ 50mm diameter	60	60	✓	✓						-



Appendix UL-EU CERTIFICATE

Certificate No. UL-EU-01058-CPR
 Page 15/144
 Date of Issue 2017-10-27

Service	Integrity	Integrity & Insulation	Rigid Wall Thickness (mm)					Flexible Wall Thickness (mm)		Additional Requirements (Both Sides)
	E (mins)	EI (mins)	≥ 215	≥ 150	≥ 130	≥ 110	≥ 100	≥ 130	≥ 100	
1 type D2 cable ≤ 65mm diameter	60	60	✓	✓						-
1 type G1 cable ≤ 15mm diameter	60	60	✓	✓						-
Bundle of ≤ 40mm diameter twin & earth cables, each ≤ 17mm diameter	60	60	✓	✓						-
Bundle of ≤ 35mm diameter fire alarm cables, each ≤ 12mm diameter	60	60	✓	✓						-
Bundle of ≤ 30mm diameter TV coaxial cables, each ≤ 10mm diameter	60	60	✓	✓						-
Bundle of ≤ 7 twin and earth cables, each ≤ 17mm diameter, in a ≤ 55mm x 3.2mm ABS Conduit	60	60	✓	✓						1 layer of FP302 Intustrap, sealed within FB750 Intubatt with FS702 Intumastic
Bundle of ≤ 6 twin and earth cables, each ≤ 17mm diameter, in a ≤ 55mm x 3.2mm ABS Conduit	60	60	✓	✓						25mm annulus of FS709 HP Intumescent Sealant, 25mm depth (using FB750 as backer)
1 type D2 Cable ≤ 65mm diameter	120	60	✓							-
≤ 2 type A2 cables, each ≤ 12mm diameter	120	60	✓							-
1 type A2 cable ≤ 12mm diameter	120	60	✓							-

Cable diameters can be increased up to 25%, and cable bundle diameters can be increased up to 10%



Appendix UL-EU CERTIFICATE

Certificate No. UL-EU-01058-CPR
Page 16/144
Date of Issue 2017-10-27

Cables and Cable Carriers – Double Batt Compression

Cables, Metal Cable Trays, Trunking, Baskets and Ladders passing through Flexible and Rigid Walls as identified below, protected by double compressed FB750 Intubatt seal, sealed with FS702 Intumastic or FS712 Intucoat.
Wall Details: Flexible or Rigid Walls including Concrete, Brick / Blockwork & AAC, of minimum thickness as identified below, and with performance classified to EN 13501-2. Flexible Walls constructed from steel or timber faced studs with a minimum of 2 x 12.5mm EN 520 type F boards on each side of studs.
Maximum Opening size: 1100mm by 1100mm. In Flexible Walls openings should be created using a steel frame. Multiple openings must be separated by a minimum of 200mm for fire resistance requirements. Check separation requirements with the system owner of the supporting construction.
Installation Instructions: Double Layer board, compressed and bonded into the aperture outer face flush with the face of the supporting construction. FB750 Intubatt should be installed in as few cut pieces as possible and tightly compressed to two opposite sides. This is achieved by the addition of 2mm to the required cut dimension. Compression may be applied - FB750 Intubatt to FB750 Intubatt, FB750 Intubatt to non-combustible service, or FB750 Intubatt to Substrate. Compression must be achieved over a minimum 60% of the FB750 Intubatt compressed edge. If compression is achieved Top to bottom of FB750 Intubatt, left/right is not required to be compressed and vice versa (the non-compressed seal should be fully abutted and bonded). All joints are to be bonded using FS712 Intucoat to full width of the FB750 Intubatt or FS702 Intumastic applied as a 10mm bead along the full-length joint centre line. FS702 Intumastic should be used to point all service and substrate interfaces, to a minimum of a 6mm bead. Apertures for penetrating services are to be tightly fitted and sealed. Imperfections should be filled with FS702 Intumastic to the full depth of the FB750 Intubatt. Service openings should be cut no more than 15mm away from non-combustible services, and/or, openings should be cut to suit the requirements of any additional required Nullifire product, if the service type is combustible or insulated CS or LS. (Imperfections in cut on a compressed edge may not exceed 40% of the area available to receive compression)
The results below are also applicable when using multiple layers of FB750 Intubatt, including 1 layer (or more) surface mounted on both sides of the wall.

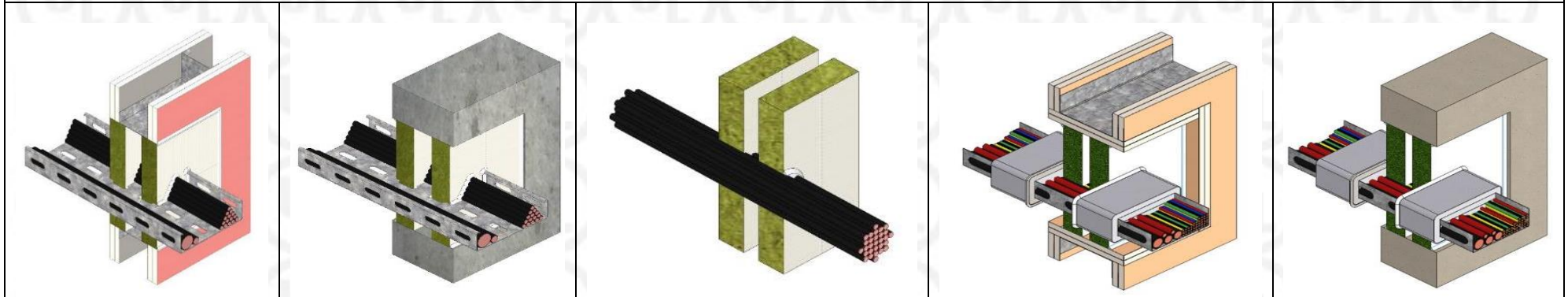

Form-ULID-006104 (DCS:27-CP-F0855) 5.0



Appendix UL-EU CERTIFICATE

Certificate No. UL-EU-01058-CPR
 Page 17/144
 Date of Issue 2017-10-27

Service	Integrity E (mins)	Integrity & Insulation EI (mins)	Rigid Wall Thickness (mm)				Flexible Wall Thickness (mm)		Additional Requirements (Both Sides)
			≥ 215	≥ 150	≥ 130	≥ 100	≥ 130	≥ 100	
Metal Cable Trays, Trunking, Baskets and Ladder ≤ 450mm width	120	120	✓	✓	✓		✓		200mm extension of 1 layer of FI025 Intuflex, taped with aluminium foil (min 30 micron), abutting FB750 Intubatt
Metal Cable Trays, Trunking, Baskets and Ladder ≤ 450mm width	120	120	✓	✓					≤ 85mm high FS709 HP Intumescent Sealant above cable tray, 50mm depth
Bundle of ≤ 37 twin & earth cables, each ≤ 17mm diameter	240	240	✓	✓					200mm extension of 1 layer of FI025 Intuflex, taped with aluminium foil (min 30 micron), abutting FB750 Intubatt
Bundle of ≤ 20 Cat 5 Ethernet cables, each ≤ 6mm diameter in ≤ 55mm x (0.5 to 1.2mm) Ribbed Nylon Copex combustible conduit	120	120	✓	✓	✓	✓	✓	✓	1 layer of FP302 Intustrap (central to the seal), sealed with FS702 Intumastic
Bundle of ≤ 100mm diameter type F cables, each ≤ 13mm diameter	120	120	✓	✓	✓		✓		200mm extension of 1 layer of FI025 Intuflex, taped with aluminium foil (min 30 micron), abutting FB750 Intubatt
Bundle of ≤ 10 A1 cables, each ≤ 12mm	120	120	✓	✓	✓		✓		200mm extension of 1 layer of FI025 Intuflex, taped with aluminium foil (min 30 micron), abutting FB750 Intubatt
Bundle of ≤ 10 A3 cables, each ≤ 12mm diameter	120	120	✓	✓	✓		✓		200mm extension of 1 layer of FI025 Intuflex, taped with aluminium foil (min 30 micron), abutting FB750 Intubatt
≤ 2 type B cables, each ≤ 19mm diameter	120	120	✓	✓	✓		✓		200mm extension of 1 layer of FI025 Intuflex, taped with aluminium foil (min 30 micron), abutting FB750 Intubatt
1 type C1 cable ≤ 41mm diameter	120	120	✓	✓	✓		✓		200mm extension of 1 layer of FI025 Intuflex, taped with aluminium foil (min 30 micron), abutting FB750 Intubatt
1 type C2 cable ≤ 50mm diameter	120	120	✓	✓	✓		✓		200mm extension of 1 layer of FI025 Intuflex, taped with aluminium foil (min 30 micron), abutting FB750 Intubatt
1 type D1 cable ≤ 55mm diameter	120	120	✓	✓	✓		✓		200mm extension of 1 layer of FI025 Intuflex, taped with aluminium foil (min 30 micron), abutting FB750 Intubatt
1 type D3 cable ≤ 52.5mm diameter	120	120	✓	✓	✓		✓		200mm extension of 1 layer of FI025 Intuflex, taped with aluminium foil (min 30 micron), abutting FB750 Intubatt
≤ 2 type E cables, each ≤ 25mm diameter	120	120	✓	✓	✓		✓		200mm extension of 1 layer of FI025 Intuflex, taped with aluminium foil (min 30 micron), abutting FB750 Intubatt
1 type G1 cable ≤ 15mm diameter	120	120	✓	✓	✓		✓		200mm extension of 1 layer of FI025 Intuflex, taped with aluminium foil (min 30 micron), abutting FB750 Intubatt

Form-ULID-006104 (DCS:27-CP-F0855) 5.0



Appendix UL-EU CERTIFICATE

Certificate No. UL-EU-01058-CPR
 Page 18/144
 Date of Issue 2017-10-27

Service	Integrity	Integrity & Insulation	Rigid Wall Thickness (mm)				Flexible Wall Thickness (mm)		Additional Requirements (Both Sides)
			E (mins)	EI (mins)	≥ 215	≥ 150	≥ 130	≥ 100	
1 type G2 cable ≤ 20mm diameter	120	120	✓	✓	✓		✓		200mm extension of 1 layer of FI025 Intuflex, taped with aluminium foil (min 30 micron), abutting FB750 Intubatt
1 type D2 cable ≤ 65mm diameter	120	120	✓	✓	✓		✓		200mm extension of 1 layer of FI025 Intuflex, taped with aluminium foil (min 30 micron), abutting FB750 Intubatt
Bundle of ≤ 12 twin & earth cables - each ≤ 17mm diameter	120	120	✓	✓					Cone (60mm circumference, 60mm along the cable) of FS702 Intumastic to outside of FB750 Intubatt seal
Bundle of ≤ 100mm Diameter A1 cable, each ≤ 12mm diameter	120	120	✓	✓					≤ 85mm high FS709 HP Intumescent Sealant, 50mm depth
Bundle of ≤ 9 TV Coaxial cables, each ≤ 12mm, in a ≤ 55mm x 3.2mm ABS Conduit	120	120	✓	✓					2 layers of FP302 Intustrap (central to the seal) sealed with FS702 Intumastic
Bundle of ≤ 3 Fire alarm cables, each ≤ 10mm, in a ≤ 55mm x 3.2mm ABS Conduit	120	120	✓	✓					2 layers of FP302 Intustrap (central to the seal) sealed with FS702 Intumastic
Bundle of ≤ 12 Fibre optic cables, each ≤ 8mm, in a ≤ 55mm x 3.2mm ABS Conduit	120	120	✓	✓					1 layer of FP302 Intustrap (central to the seal) sealed with FS702 Intumastic
1 type C2 cable ≤ 50mm diameter	120	120	✓	✓					≤ 85mm high FS709 HP Intumescent Sealant, 50mm depth
1 type D2 cable ≤ 65mm diameter	120	120	✓	✓					≤ 85mm high FS709 HP Intumescent Sealant, 50mm depth
1 TV coaxial cable ≤ 10mm diameter	120	120	✓	✓					Cone (60mm circumference, 60mm along the cable) of FS702 Intumastic to outside of FB750 Intubatt seal
1 type G2 cable ≤ 20mm diameter	120	90	✓	✓					Cone (100mm circumference, 60mm along the cable) of FS702 Intumastic to outside of FB750 Intubatt seal
Bundle of ≤ 40mm diameter type F cables, each ≤ 13mm diameter	90	90	✓	✓	✓				-
Bundle of ≤ 7 twin and earth cables, each ≤ 17mm, in a ≤ 55mm x 3.2mm ABS Conduit	60	60	✓	✓					1 layer of FP302 Intustrap (central to the seal) sealed with FS702 Intumastic
Bundle of ≤ 6 twin and earth cables, each ≤ 17mm, in a ≤ 55mm x 3.2mm ABS Conduit	60	60	✓	✓					25mm annulus of FS709 HP Intumescent Sealant, 25mm depth (using FB750 as backer)
Bundle of ≤ 7 twin & earth cables, each ≤ 17mm diameter	60	60	✓	✓					1 layer of FP302 Intustrap (central to the seal) sealed with FS702 Intumastic



Appendix UL-EU CERTIFICATE

Certificate No. UL-EU-01058-CPR
 Page 19/144
 Date of Issue 2017-10-27

Service	Integrity	Integrity & Insulation	Rigid Wall Thickness (mm)				Flexible Wall Thickness (mm)		Additional Requirements (Both Sides)
	E (mins)	EI (mins)	≥ 215	≥ 150	≥ 130	≥ 100	≥ 130	≥ 100	
Bundle of ≤ 6 twin & earth cables, each ≤ 17mm diameter	60	60	✓	✓					25mm annulus of FS709 HP Intumescent Sealant, 25mm depth (using FB750 as backer)
Bundle of ≤ 40mm diameter twin & earth cables, each ≤ 17mm diameter	60	60	✓	✓					-
Bundle of ≤ 100mm Diameter A1 cables, each ≤ 12mm diameter	60	60	✓	✓					-
Bundle of ≤ 30mm diameter Fire alarm cables, each ≤ 12mm	60	60	✓	✓					-
Bundle of ≤ 6 Fire alarm cables, each ≤ 12mm	60	60	✓	✓					2 layers of FP302 Intustrap (central to the seal) sealed with FS702 Intumastic
Bundle of ≤ 30mm diameter TV coaxial cables, each ≤ 10mm diameter	60	60	✓	✓					-
Bundle of ≤ 8 TV coaxial cable, each ≤ 10mm diameter	60	60	✓	✓					2 layers of FP302 Intustrap (central to the seal) sealed with FS702 Intumastic
1 type C2 cable ≤ 50mm diameter	60	60	✓	✓					-
1 type D2 cable ≤ 65mm diameter	60	60	✓	✓					-
1 type C3 cable ≤ 37mm diameter	90	30	✓	✓	✓				-
1 type D2 Cable ≤ 65mm diameter	120	60	✓						-
≤ 2 type A2 cables, each ≤ 12mm diameter	120	60	✓						-
≤ 2 type E Cables - each ≤ 25mm diameter	120	30	✓						-
Bundle of ≤ 6 type A2 cables, each ≤ 12mm diameter	120	30	✓						-

Cable diameters can be increased up to 25%, and cable bundle diameters can be increased up to 10%



Appendix UL-EU CERTIFICATE

Certificate No. UL-EU-01058-CPR
Page 20/144
Date of Issue 2017-10-27

Cables and Cable Carriers – Double Batt Compression (Asymmetric)

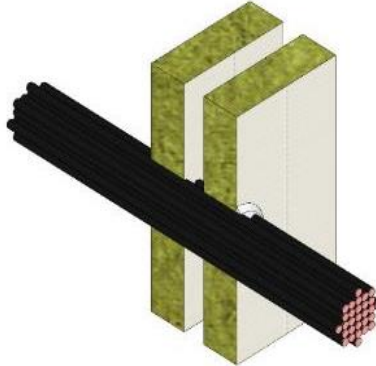
Cables, Metal Cable Trays, Trunking, Baskets and Ladders passing through Rigid Walls as identified below, protected by double compressed asymmetric FB750 Intubatt seal, sealed with FS702 Intumastic or FS712 Intucoat.
Wall Details: Rigid Walls including Concrete, Brick / Blockwork & AAC, of minimum thickness as identified below and with performance classified to EN13501-2.
Maximum Opening size: 1100mm by 450mm. Multiple openings must be separated by a minimum of 200mm for fire resistance requirements. Check separation requirements with the system owner of the supporting construction.
Installation Instructions: Double Layer board, compressed and bonded together in the aperture with the outer face flush with the face of the supporting construction on the opposite side to the fire. FB750 Intubatt should be installed in as few cut pieces as possible and tightly compressed to two opposite sides. This is achieved by the addition of 2mm to the required cut dimension. Compression may be applied - FB750 Intubatt to FB750 Intubatt, FB750 Intubatt to non-combustible service, or FB750 Intubatt to Substrate. Compression must be achieved over a minimum 60% of the FB750 Intubatt compressed edge. If compression is achieved Top to bottom of FB750 Intubatt, left/right is not required to be compressed and vice versa (the non-compressed seal should be fully abutted and bonded). All joints are to be bonded using FS712 Intucoat to full width of the FB750 Intubatt or FS702 Intumastic applied as a 10mm bead along the full-length joint centre line. FS702 Intumastic should be used to point all service and substrate interfaces, to a minimum of a 6mm bead. Apertures for penetrating services are to be tightly fitted and sealed. Imperfections should be filled with FS702 Intumastic to the full depth of the FB750 Intubatt. Service openings should be cut no more than 15mm away from non-combustible services, and/or, openings should be cut to suit the requirements of any additional required Nullifire product, if the service type is combustible or insulated CS or LS. (Imperfections in cut on a compressed edge may not exceed 40% of the area available to receive compression)
The results below are also applicable when using multiple layers of FB750 Intubatt, including 2 layers (or more) surface mounted. Results could also be used in both directions with the addition of FB750 Intubatt to fully fill the opening.

Form-ULID-006104 (DCS:27-CP-F0855) 5.0



Appendix UL-EU CERTIFICATE

Certificate No. UL-EU-01058-CPR
 Page 21/144
 Date of Issue 2017-10-27

Service	Integrity	Integrity & Insulation	Flexible Wall Thickness (mm)	Additional Requirements (Both Sides)
	E (mins)	EI (mins)	≥ 150	
Metal Cable Trays, Trunking, Baskets and Ladders ≤ 500mm width	240	180	✓	200mm extension of 1 layer of FI025 Intuflex, sealed to FB750 Intubatt with FS702 Intumastic
Metal Cable Trays, Trunking, Baskets and Ladders ≤ 300mm width	180	180	✓	-
Metal Cable Trays, Trunking, Baskets and Ladders ≤ 340mm width	240	60	✓	-
Bundle of ≤ 10 A1 cables, each ≤ 12mm	240	180	✓	200mm extension of 1 layer of FI025 Intuflex, sealed to FB750 Intubatt with FS702 Intumastic
Bundle of ≤ 5 A2 cables, each ≤ 12mm	240	180	✓	200mm extension of 1 layer of FI025 Intuflex, sealed to FB750 Intubatt with FS702 Intumastic
Bundle of ≤ 100mm diameter type F cables, each ≤ 13mm diameter	240	180	✓	200mm extension of 1 layer of FI025 Intuflex, sealed to FB750 Intubatt with FS702 Intumastic
Bundle of ≤ 5 A3 cables, each ≤ 12mm	240	180	✓	200mm extension of 1 layer of FI025 Intuflex, sealed to FB750 Intubatt with FS702 Intumastic
≤ 3 type G1 cables, each ≤ 15mm diameter	240	180	✓	200mm extension of 1 layer of FI025 Intuflex, sealed to FB750 Intubatt with FS702 Intumastic
≤ 2 type G2 cables, each ≤ 20mm diameter	240	180	✓	200mm extension of 1 layer of FI025 Intuflex, sealed to FB750 Intubatt with FS702 Intumastic
Bundle of ≤ 10 A1 cables, each ≤ 12mm	180	180	✓	-
Bundle of ≤ 5 A2 cables, each ≤ 12mm	240	60	✓	-
Bundle of ≤ 5 A3 cables, each ≤ 12mm	240	60	✓	-
≤ 3 type G1 cables, each ≤ 15mm diameter	240	60	✓	-

Cable diameters can be increased up to 25%, and cable bundle diameters can be increased up to 10%



Appendix UL-EU CERTIFICATE

Certificate No. UL-EU-01058-CPR
Page 22/144
Date of Issue 2017-10-27

Cables and Cable Carriers – Single Batt Compression

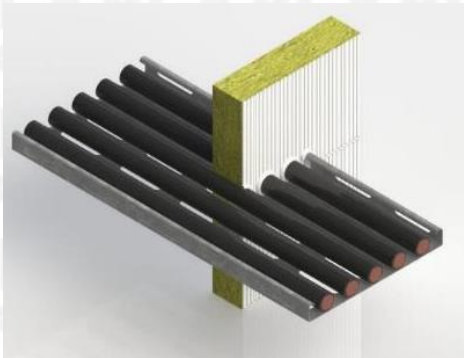
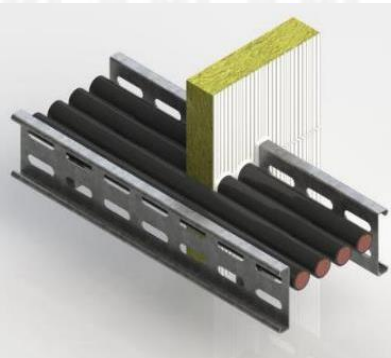
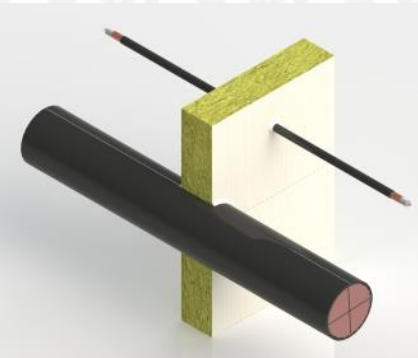
Cables, Metal Cable Trays, Trunking, Baskets and Ladders passing through Flexible and Rigid Walls as identified below, protected by single compressed FB750 Intubatt seal, sealed with FS702 Intumastic or FS712 Intucoat.		
Wall Details: Flexible or Rigid Walls including Concrete, Brick / Blockwork & AAC, of minimum thickness as identified below, and with performance classified to EN 13501-2. Flexible Walls constructed from steel or timber faced studs with a minimum of 2 x 12.5mm EN 520 type F boards on each side of studs.		
Maximum Opening size: 1100mm by 1100mm. In Flexible Walls openings should be created using a steel frame with a plasterboard lining. Multiple openings must be separated by a minimum of 200mm for fire resistance requirements. Check separation requirements with the system owner of the supporting construction.		
Installation Instructions: Single Layer board, compressed and bonded into the aperture at mid depth of the wall. FB750 Intubatt should be installed in as few cut pieces as possible and tightly compressed to two opposite sides. This is achieved by the addition of 2mm to the required cut dimension. Compression may be applied - FB750 Intubatt to FB750 Intubatt, FB750 Intubatt to non-combustible service, or FB750 Intubatt to Substrate. Compression must be achieved over a minimum 60% of the FB750 Intubatt Compressed edge. If compression is achieved Top to bottom of FB750 Intubatt, left/right is not required to be compressed and vice versa (the non-compressed seal should be fully abutted and bonded). All joints are to be bonded using FS712 Intucoat to full width of the FB750 Intubatt or FS702 Intumastic applied as a 10mm bead along the full-length joint centre line. FS702 Intumastic should be used to point all service and substrate interfaces, to a minimum of a 6mm bead. Apertures for penetrating services are to be tightly fitted and sealed. Imperfections should be filled with FS702 Intumastic to the full depth of the FB750 Intubatt. Service openings should be cut no more than 15mm away from non-combustible services, and/or, openings should be cut to suit the requirements of any additional required Nullfire product, if the service type is combustible or insulated CS or LS. (Imperfections in cut on a compressed edge may not exceed 40% of the area available to receive compression)		
The results below are also applicable when using multiple layers of FB750 Intubatt, including 1 layer (or more) surface mounted on both sides of the wall.		
		

Form-ULID-006104 (DCS:27-CP-F0855) 5.0



Appendix UL-EU CERTIFICATE

Certificate No. UL-EU-01058-CPR
 Page 23/144
 Date of Issue 2017-10-27

Service	Integrity	Integrity & Insulation	Rigid Wall Thickness (mm)		Flexible Wall Thickness (mm)	Additional Requirements (Both Sides)
	E (mins)	EI (mins)	≥ 215	≥ 130	≥ 130	
Metal Cable Trays, Trunking, Baskets and Ladders ≤ 500mm width & minimum 1mm thickness	120	90	✓	✓	✓	200mm extension of 1 layer of FI025 Intuflex, taped with aluminium foil (min 30 micron), abutting FB750 Intubatt
Metal Cable Trays, Trunking, Baskets and Ladders ≤ 600mm width & minimum 3mm thickness	120	60	✓			-
Bundle of ≤ 100mm diameter type F data cables - each cable ≤ 13mm diameter	120	120	✓	✓	✓	200mm extension of 1 layer of FI025 Intuflex, taped with aluminium foil (min 30 micron), abutting FB750 Intubatt
Bundle of ≤ 10 type A1 cables, each cable ≤ 12mm diameter	120	90	✓	✓	✓	200mm extension of 1 layer of FI025 Intuflex, taped with aluminium foil (min 30 micron), abutting FB750 Intubatt
Bundle of ≤ 10 type A2 cables, each cable ≤ 12mm diameter	120	90	✓	✓	✓	200mm extension of 1 layer of FI025 Intuflex, taped with aluminium foil (min 30 micron), abutting FB750 Intubatt
Bundle of ≤ 10 type A3 cables, each cable ≤ 12mm diameter	120	90	✓	✓	✓	200mm extension of 1 layer of FI025 Intuflex, taped with aluminium foil (min 30 micron), abutting FB750 Intubatt
≤ 2 type B cables, each cable ≤ 19mm diameter	120	90	✓	✓	✓	200mm extension of 1 layer of FI025 Intuflex, taped with aluminium foil (min 30 micron), abutting FB750 Intubatt
1 type C1 cable ≤ 41mm diameter	120	90	✓	✓	✓	200mm extension of 1 layer of FI025 Intuflex, taped with aluminium foil (min 30 micron), abutting FB750 Intubatt
1 type C2 cable ≤ 50mm diameter	120	90	✓	✓	✓	200mm extension of 1 layer of FI025 Intuflex, taped with aluminium foil (min 30 micron), abutting FB750 Intubatt
1 type C3 cable ≤ 37mm diameter	120	90	✓	✓	✓	200mm extension of 1 layer of FI025 Intuflex, taped with aluminium foil (min 30 micron), abutting FB750 Intubatt
1 type D1 cable ≤ 55mm diameter	120	90	✓	✓	✓	200mm extension of 1 layer of FI025 Intuflex, taped with aluminium foil (min 30 micron), abutting FB750 Intubatt
1 type D2 cable ≤ 52.5mm diameter	120	90	✓	✓	✓	200mm extension of 1 layer of FI025 Intuflex, taped with aluminium foil (min 30 micron), abutting FB750 Intubatt

Form-ULID-006104 (DCS:27-CP-F0855) 5.0



Appendix UL-EU CERTIFICATE

Certificate No. UL-EU-01058-CPR
 Page 24/144
 Date of Issue 2017-10-27

Service	Integrity	Integrity & Insulation	Rigid Wall Thickness (mm)		Flexible Wall Thickness (mm)	Additional Requirements (Both Sides)
	E (mins)	EI (mins)	≥ 215	≥ 130	≥ 130	
1 type D3 cable ≤ 52.5mm diameter	120	90	✓	✓	✓	200mm extension of 1 layer of FI025 Intuflex, taped with aluminium foil (min 30 micron), abutting FB750 Intubatt
≤ 2 type E cables, each cable ≤ 25mm diameter	120	90	✓	✓	✓	200mm extension of 1 layer of FI025 Intuflex, taped with aluminium foil (min 30 micron), abutting FB750 Intubatt
1 type G1 cable ≤ 15mm diameter	120	90	✓	✓	✓	200mm extension of 1 layer of FI025 Intuflex, taped with aluminium foil (min 30 micron), abutting FB750 Intubatt
1 type G2 cable ≤ 20mm diameter	120	90	✓	✓	✓	200mm extension of 1 layer of FI025 Intuflex, taped with aluminium foil (min 30 micron), abutting FB750 Intubatt
1 type A2 cable ≤ 12mm diameter	120	60	✓			-
1 type D2 cable ≤ 65mm diameter	120	60	✓			-
≤ 2 type A2 cables, each cable ≤ 12mm diameter	120	60	✓			-
1 type E cable ≤ 25mm diameter	120	30	✓			-
Bundle of ≤ 6 type A2 cables, each cable ≤ 12mm diameter	120	30	✓			-
≤ 2 type E cables, each cable ≤ 25mm diameter	120	30	✓			-
Bundle of ≤ 7 type F data cables, each cable ≤ 13mm diameter	90	30	✓			-

Cable diameters can be increased up to 25%, and cable bundle diameters can be increased up to 10%



Appendix UL-EU CERTIFICATE

Certificate No. UL-EU-01058-CPR
Page 25/144
Date of Issue 2017-10-27

Cables and Cable Carriers – Double Batt Pattress Batt Box

Cables, Metal Cable Trays, Trunking, Baskets and Ladders insulated within a batt box passing through Flexible and Rigid Walls as identified below, protected by double pattress (surface mounted) FB750 Intubatt seal, sealed with FS702 Intumastic.

Wall Details: Flexible or Rigid Walls including Concrete, Brick / Blockwork & AAC, of minimum thickness as identified below, and with performance classified to EN 13501-2.
Flexible Walls constructed from steel or timber faced studs with a minimum of 2 x 12.5mm EN 520 type F boards on each side of studs.

Maximum Opening size: 1600mm by 1000mm. Multiple openings must be separated by a minimum of 200mm for fire resistance requirements. Check separation requirements with the system owner of the supporting construction.

Installation Instructions: Cut FB750 Intubatt to form batt box detail around cable tray(s) as per detail drawing below. Position the batt box around the penetration flush with the wall face on both faces of the compartment, extending 150mm away from the compartment wall. Cut FB750 Intubatt to the required size and shape, ensuring it will be a tight fit to all edges of the aperture. Cut the FB750 Intubatt to tightly fit around the batt box detail, using a single layer board to each side, pattress requirements explained below. The remaining aperture within the batt box should be completely filled with FI064 Soft Joint Filler and coated to each side with 3mm WFT FS702 Intumastic. Cut the FB750 Intubatt across the shortest dimension aligning both to the midpoint of the batt box, to enable the FB750 Intubatt to be fitted in to the aperture. Apply FS702 Intumastic to all edges of the FB750 Intubatt, ensuring that an even cover is achieved over the entire exposed thickness of the FB750 Intubatt, this should include the outer edges of the FB750 Intubatt and the cut across to allow installation in the aperture. Boards surface mounted on both sides of the wall with a minimum 75mm overlap around the opening. (Overlap on the lowest edge can be reduced to 30mm in the event of an obstruction preventing the 75mm overlap). The overlap should be bonded with a 10mm bead of FS702 Intumastic placed 20-60mm from the board edges, and additionally mechanically restrained using 75mm steel screws with a 25mm washer at maximum 300mm centres, 10-65mm from the board perimeter and no more than 50mm from a board joint. A low torque setting should be used to ensure that the embedment of fixing into the board does not exceed 15mm. The fixings may be left exposed or covered using FS702 Intumastic. The FB750 Intubatt should be installed in as few cut pieces as possible. All joints are to be bonded using FS712 Intucoat to full width of the FB750 Intubatt or FS702 Intumastic applied as a 10mm bead along the full-length joint centre line. FS702 Intumastic should be used to point all service and substrate interfaces, to a minimum of a 6mm bead. External sides of the Board may be required to be coated for aesthetic reasons or to prevent fibre migration. (In situations where the required overlap cannot be achieved due to a perpendicular fire resisting wall / soffit, it is possible to reduce the overlap, down to as low as 0mm, provided the board edge is bonded to the adjoining compartment using a 10mm bead of FS702 Intumastic, and subsequently pointed to all mated edges). Batt Box is only required to be installed round cables, trays (perforated or non-perforated), ladders, baskets and trunking. If included within a mixed penetration seal, the rest of the seal should be completed as per the normal surface mounted batt requirement.

The results below are also applicable when using multiple layers of surface mounted FB750 Intubatt. For multiple layers of FB750 Intubatt so a single (or both) face, identically sized boards should be used, ideally with staggered joints where possible. Closing devices should be located in or on the outmost board. Board to board abutment should be bonded with 10mm bead of FS702 Intumastic and mechanically restrained using a 75mm spiral screw to the first and secured layer. Spiral fixings should be at max 200mm centres and no more than 50mm from any joint.

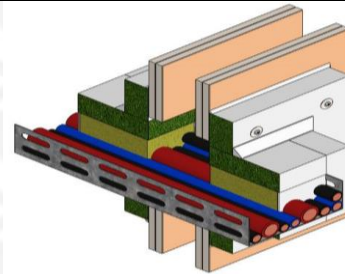

Form-ULID-006104 (DCS:27-CP-F0855) 5.0



Appendix UL-EU CERTIFICATE

Certificate No. UL-EU-01058-CPR
 Page 26/144
 Date of Issue 2017-10-27

Service	Integrity	Integrity & Insulation	Rigid Wall Thickness (mm)		Flexible Wall Thickness (mm)	
	E (mins)	EI (mins)	≥ 130	≥ 100	≥ 130	≥ 100
Metal Cable Trays, Trunking, Baskets and Ladder ≤ 500mm width	120	120	✓	✓	✓	✓
Bundle of ≤ 10 type A1 cables, each cable ≤ 12mm diameter	120	120	✓	✓	✓	✓
Bundle of ≤ 10 type A2 cables, each cable ≤ 12mm diameter	120	120	✓	✓	✓	✓
Bundle of ≤ 10 type A3 cables, each cable ≤ 12mm diameter	120	120	✓	✓	✓	✓
1 type D2 cable ≤ 65mm diameter	120	120	✓	✓	✓	✓
1 type C2 cable ≤ 50mm diameter	120	120	✓	✓	✓	✓
Bundle of ≤ 100mm diameter type F data cables, each cable ≤ 13mm diameter	120	120	✓		✓	
≤ 2 type B cables, each cable ≤ 19mm diameter	120	120	✓		✓	
1 type C1 cable ≤ 41mm diameter	120	120	✓		✓	
1 type C2 cable ≤ 50mm diameter	120	120	✓		✓	
1 type C3 cable ≤ 37mm diameter	120	120	✓		✓	
1 type D1 cable ≤ 55mm diameter	120	120	✓		✓	
1 type D2 cable ≤ 65mm diameter	120	120	✓		✓	
1 type D3 cable ≤ 52.5mm diameter	120	120	✓		✓	
≤ 2 type E Cables ≤ 25mm diameter	120	120	✓		✓	
1 type G1 cable ≤ 15mm diameter	120	120	✓		✓	

Form-ULID-006104 (DCS:27-CP-F0855) 5.0



Appendix UL-EU CERTIFICATE

Certificate No. UL-EU-01058-CPR
 Page 27/144
 Date of Issue 2017-10-27

Service	Integrity	Integrity & Insulation	Rigid Wall Thickness (mm)		Flexible Wall Thickness (mm)	
	E (mins)	EI (mins)	≥ 130	≥ 100	≥ 130	≥ 100
1 type G2 cable ≤ 20mm diameter	120	120	✓		✓	
Bundle of ≤ 9 type A1 Cables, each ≤ 12mm diameter, within a ≤ 340mm x 140mm steel trunking 300mm in length, filled with FI064 Backer (64kg/m ³ RF), and coated using 3mm WFT FS702 Intumastic to both faces	120	120	✓		✓	
Bundle of ≤ 9 type A2 Cables, each ≤ 12mm diameter, within a ≤ 340mm x 140mm steel trunking 300mm in length, filled with FI064 Backer (64kg/m ³ RF), and coated using 3mm WFT FS702 Intumastic to both faces	120	120	✓		✓	
≤ 2 type E Cables ≤ 25mm diameter, within a ≤ 340mm x 140mm steel trunking 300mm in length, filled with FI064 Backer (64kg/m ³ RF), and coated using 3mm WFT FS702 Intumastic to both faces	120	120	✓		✓	
Bundle of ≤ 100mm diameter type F data cables, each cable ≤ 13mm diameter	120	90	✓	✓	✓	✓
1 type G1 cable ≤ 15mm diameter	120	90	✓	✓	✓	✓
1 type G2 cable ≤ 20mm diameter	120	90	✓	✓	✓	✓
1 type C1 cable ≤ 41mm diameter	120	90	✓	✓	✓	✓
1 type C3 cable ≤ 37mm diameter	120	90	✓	✓	✓	✓
1 type D1 cable ≤ 55mm diameter	120	90	✓	✓	✓	✓



Appendix UL-EU CERTIFICATE

Certificate No. UL-EU-01058-CPR
 Page 28/144
 Date of Issue 2017-10-27

Service	Integrity	Integrity & Insulation	Rigid Wall Thickness (mm)		Flexible Wall Thickness (mm)	
	E (mins)	EI (mins)	≥ 130	≥ 100	≥ 130	≥ 100
1 type D3 cable ≤ 52.5mm diameter	120	60	✓	✓	✓	✓
≤ 2 type B cables, each cable ≤ 19mm diameter	120	60	✓	✓	✓	✓
2 type E cables ≤ 25mm diameter	120	60	✓	✓	✓	✓
1 type G2 cable ≤ 20mm diameter, within a ≤ 340mm x 140mm steel trunking 300mm in length, filled with FI064 Backer (64kg/m ³ RF), and coated using 3mm WFT FS702 Intumastic to both faces	120	90	✓		✓	

Cable diameters can be increased up to 25%, and cable bundle diameters can be increased up to 10%



Appendix UL-EU CERTIFICATE

Certificate No. UL-EU-01058-CPR
Page 29/144
Date of Issue 2017-10-27

Cables and Cable Carriers – Double Batt Compression Batt Box

Cables, Metal Cable Trays, Trunking, Baskets and Ladders insulated within a batt box passing through Flexible and Rigid Walls as identified below, protected by double compressed FB750 Intubatt seal, sealed with FS702 Intumastic.	
Wall Details: Flexible or Rigid Walls including Concrete, Brick / Blockwork & AAC, of minimum thickness as identified below, and with performance classified to EN 13501-2. Flexible Walls constructed from steel or timber faced studs with a minimum of 2 x 12.5mm EN 520 type F boards on each side of studs.	
Maximum Opening size: 1800mm by 1200mm. In Flexible Walls openings should be created using a steel frame. Multiple openings must be separated by a minimum of 200mm for fire resistance requirements. Check separation requirements with the system owner of the supporting construction.	
Installation Instructions: Cut FB750 Intubatt to form batt box detail around cable tray(s) as per detail drawing below. Position the batt box around the penetration and position the centre of the batt box in line with the centre of the proposed FB750 Intubatt seal. Cut FB750 Intubatt to the required size and shape, ensuring it will be a tight fit to all edges of the aperture. Cut the FB750 Intubatt to tightly fit around the batt box detail, using a double Layer board, compressed and bonded into the aperture at mid depth of the wall. FS702 Intumastic or FS712 Intucoat is to be used to bond and form a seal between the batt box and the abutment of the wall and board to board joints. The remaining aperture within the batt box should be completely filled with FI064 Soft Joint Filler and coated to each side with 3mm WFT FS702 Intumastic. Cut the FB750 Intubatt across the shortest dimension aligning both to the midpoint of the batt box, to enable the FB750 Intubatt to be fitted in to the aperture. Apply FS702 Intumastic to all edges of the FB750 Intubatt, ensuring that an even cover is achieved over the entire exposed thickness of the FB750 Intubatt, this should include the outer edges of the FB750 Intubatt and the cut across to allow installation in the aperture. Insert the FB750 Intubatt in the opening. Apply a bead of FS702 Intumastic to approximately 6mm by 6mm wide to the perimeter and 20mm by 20mm around the batt box detail, where the FB750 Intubatt meets the aperture and penetration. Ensure that all gaps between the FB750 Intubatt and the surrounding edges are fully filled. Repair any damages to the coating which may have occurred during installation using FS702 Intumastic or FS712 Intucoat. Repeat FS702 / FS712 seal to the opposite side of wall. Batt Box is only required to be installed round cables, trays (perforated or non-perforated), ladders, baskets and trunking. If included within a mixed penetration seal, the rest of the seal should be completed as per the normal double batt requirement.	
The results below are also applicable when using multiple layers of FB750 Intubatt, including 1 layer (or more) surface mounted on both sides of the wall.	

Form-ULID-006104 (DCS:27-CP-F0855) 5.0



Appendix UL-EU CERTIFICATE

Certificate No. UL-EU-01058-CPR
 Page 30/144
 Date of Issue 2017-10-27

Service	Integrity	Integrity & Insulation	Rigid Wall Thickness (mm)		Flexible Wall Thickness (mm)	
	E (mins)	EI (mins)	≥ 130	≥ 100	≥ 130	≥ 100
Metal Cable Trays, Trunking, Baskets and Ladders ≤ 500mm width	120	120	✓	✓	✓	✓
Bundle of ≤ 10 type A1 cables, each cable ≤ 12mm diameter	120	120	✓	✓	✓	✓
Bundle of ≤ 10 type A2 cables, each cable ≤ 12mm diameter	120	120	✓	✓	✓	✓
Bundle of ≤ 10 type A3 cables, each cable ≤ 12mm diameter	120	120	✓	✓	✓	✓
1 type C2 cable ≤ 50mm diameter	120	120	✓	✓	✓	✓
1 type D2 cable ≤ 65mm diameter	120	120	✓	✓	✓	✓
≤ 2 type B cables, each cable ≤ 19mm diameter	120	120	✓		✓	
Bundle of ≤ 9 type A1 Cables, each ≤ 12mm diameter, within a ≤ 340mm x 140mm steel trunking 300mm in length, filled with FI064 Backer (64kg/m ³ RF), and coated using 3mm WFT FS702 Intumastic to both faces	120	120	✓		✓	
Bundle of ≤ 9 type A2 Cables, each ≤ 12mm diameter, within a ≤ 340mm x 140mm steel trunking 300mm in length, filled with FI064 Backer (64kg/m ³ RF), and coated using 3mm WFT FS702 Intumastic to both faces	120	120	✓		✓	
≤ 2 type E Cables ≤ 25mm diameter, within a ≤ 340mm x 140mm steel trunking 300mm in length, filled with FI064 Backer (64kg/m ³ RF), and coated using 3mm WFT FS702 Intumastic to both faces	120	120	✓		✓	
1 type C1 cable ≤ 41mm diameter	120	120	✓		✓	
1 type C3 cable ≤ 37mm diameter	120	120	✓		✓	
1 type D1 cable ≤ 55mm diameter	120	120	✓		✓	

Form-ULID-006104 (DCS:27-CP-F0855) 5.0



Appendix UL-EU CERTIFICATE

Certificate No. UL-EU-01058-CPR
 Page 31/144
 Date of Issue 2017-10-27

Service	Integrity	Integrity & Insulation	Rigid Wall Thickness (mm)		Flexible Wall Thickness (mm)	
	E (mins)	EI (mins)	≥ 130	≥ 100	≥ 130	≥ 100
1 type D3 cable ≤ 52.5mm diameter	120	120	✓		✓	
≤ 2 type E cables ≤ 25mm diameter	120	120	✓		✓	
Bundle of ≤ 100mm diameter type F data cables, each cable ≤ 13mm diameter	120	120	✓		✓	
1 type G1 cable ≤ 15mm diameter	120	120	✓		✓	
1 type G2 cable ≤ 20mm diameter	120	120	✓		✓	
Bundle of ≤ 100mm diameter type F data cables, each cable ≤ 13mm diameter	120	90	✓	✓	✓	✓
1 type G1 cable ≤ 15mm diameter	120	90	✓	✓	✓	✓
1 type G2 cable ≤ 20mm diameter	120	90	✓	✓	✓	✓
1 type C1 cable ≤ 41mm diameter	120	90	✓	✓	✓	✓
1 type C3 cable ≤ 37mm diameter	120	90	✓	✓	✓	✓
1 type D1 cable ≤ 55mm diameter	120	90	✓	✓	✓	✓
1 type G2 cable ≤ 20mm diameter, within a ≤ 340mm x 140mm steel trunking 300mm in length, filled with FI064 Backer (64kg/m ³ RF), and coated using 3mm WFT FS702 Intumastic to both faces	120	90	✓		✓	
1 type D3 cable ≤ 52.5mm diameter	120	60	✓	✓	✓	✓
≤ 2 type E cables ≤ 25mm diameter	120	60	✓	✓	✓	✓
≤ 2 type B cables, each cable ≤ 19mm diameter	120	60	✓	✓	✓	✓

Cable diameters can be increased up to 25%, and cable bundle diameters can be increased up to 10%



Appendix UL-EU CERTIFICATE

Certificate No. UL-EU-01058-CPR
Page 32/144
Date of Issue 2017-10-27

Cables and Cable Carriers – Single Batt Compression Batt Box

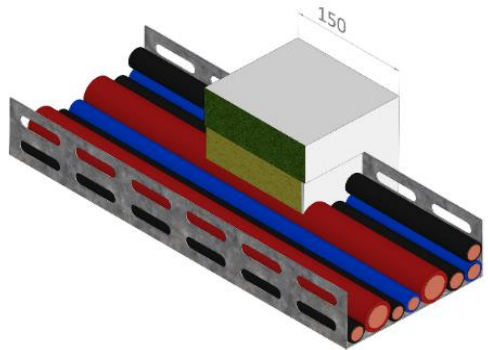
Cables, Metal Cable Trays, Trunking, Baskets and Ladders insulated within a batt box passing through Flexible and Rigid Walls as identified below, protected by single compressed FB750 Intubatt seal, sealed with FS702 Intumastic or FS712 Intucoat.
Wall Details: Flexible or Rigid Walls including Concrete, Brick / Blockwork & AAC, of minimum thickness as identified below, and with performance classified to EN 13501-2. Flexible Walls constructed from steel or timber faced studs with a minimum of 2 x 12.5mm EN 520 type F boards on each side of studs.
Maximum Opening size: 1800mm by 1200mm. In Flexible Walls openings should be created using a steel frame with a plasterboard lining. Multiple openings must be separated by a minimum of 200mm for fire resistance requirements. Check separation requirements with the system owner of the supporting construction.
Installation Instructions: Cut FB750 Intubatt to form batt box detail around cable tray(s) as per detail drawing below. Position the batt box around the penetration and position the centre of the batt box in line with the centre of the proposed FB750 Intubatt seal. Cut FB750 Intubatt to the required size and shape, ensuring it will be a tight fit to all edges of the aperture. Cut the FB750 Intubatt to tightly fit around the batt box detail, using a single Layer board, compressed and bonded into the aperture at mid depth of the wall. FS702 Intumastic or FS712 Intucoat is to be used to bond and form a seal between the batt box and the abutment of the wall and board to board joints. The remaining aperture within the batt box should be completely filled with FI064 Soft Joint Filler and coated to each side with 3mm WFT FS702 Intumastic. Cut the FB750 Intubatt across the shortest dimension aligning to the midpoint of the batt box, to enable the FB750 Intubatt to be fitted in to the aperture. Apply FS702 Intumastic to all edges of the FB750 Intubatt, ensuring that an even cover is achieved over the entire exposed thickness of the FB750 Intubatt, this should include the outer edges of the FB750 Intubatt and the cut across to allow installation in the aperture. Insert the FB750 Intubatt in the opening. Apply a bead of FS702 Intumastic to approximately 6mm by 6mm wide to the perimeter and 20mm by 20mm around the batt box detail, where the FB750 Intubatt meets the aperture and penetration. Ensure that all gaps between the FB750 Intubatt and the surrounding edges are fully filled. Repair any damages to the coating which may have occurred during installation using FS702 Intumastic or FS712 Intucoat. Repeat FS702 / FS712 seal to the opposite side of wall.
The results below are also applicable when using multiple layers of FB750 Intubatt, including 1 layer (or more) surface mounted on both sides of the wall.

Form-ULID-006104 (DCS:27-CP-F0855) 5.0



Appendix UL-EU CERTIFICATE

Certificate No. UL-EU-01058-CPR
 Page 33/144
 Date of Issue 2017-10-27

Service	Integrity	Integrity & Insulation	Rigid Wall Thickness (mm)	Flexible Wall Thickness (mm)
	E (mins)	EI (mins)	≥ 100	≥ 100
Metal Cable Trays, Trunking, Baskets and Ladders ≤ 500mm width	120	120	✓	✓
Bundle of ≤ 10 type A1 cables, each cable ≤ 12mm diameter	120	120	✓	✓
Bundle of ≤ 10 type A2 cables, each cable ≤ 12mm diameter	120	120	✓	✓
Bundle of ≤ 10 type A3 cables, each cable ≤ 12mm diameter	120	120	✓	✓
1 type D2 cable ≤ 65mm diameter	120	120	✓	✓
1 type C2 cable ≤ 50mm diameter	120	120	✓	✓
1 type C1 cable ≤ 41mm diameter	120	90	✓	✓
Bundle of ≤ 100mm diameter type F data cables, each cable ≤ 13mm diameter	120	90	✓	✓
1 type G1 cable ≤ 15mm diameter	120	90	✓	✓
1 type G2 cable ≤ 20mm diameter	120	90	✓	✓
1 type C3 cable ≤ 37mm diameter	120	90	✓	✓
1 type D1 cable ≤ 55mm diameter	120	90	✓	✓
1 type D3 cable ≤ 52.5mm diameter	120	60	✓	✓
≤ 2 type E cables ≤ 25mm diameter	120	60	✓	✓
≤ 2 type B cables, each cable ≤ 19mm diameter	120	60	✓	✓

Cable diameters can be increased up to 25%, and cable bundle diameters can be increased up to 10%

Form-ULID-006104 (DCS:27-CP-F0855) 5.0



Appendix UL-EU CERTIFICATE

Certificate No. UL-EU-01058-CPR
Page 34/144
Date of Issue 2017-10-27

Combustible Pipes – Double Batt Pattress - FS709/FP302

Combustible Pipes Insulated with No insulation passing through Flexible and Rigid Walls as identified below, protected by double pattress (surface mounted) FB750 Intubatt seal, sealed with FS702 Intumastic or FS712 Intucoat.
Wall Details: Flexible or Rigid Walls including Concrete, Brick / Blockwork & AAC, of minimum thickness as identified below, and with performance classified to EN 13501-2. Flexible Walls constructed from steel or timber faced studs with a minimum of 2 x 12.5mm EN 520 type F boards on each side of studs.
Maximum Opening size: 900mm by 550mm. Multiple openings must be separated by a minimum of 200mm for fire resistance requirements. Check separation requirements with the system owner of the supporting construction.
Installation Instructions: Boards surface mounted (pattress fit) on both sides of the wall with a minimum 75mm overlap around the opening. (Overlap on the lowest edge can be reduced to 30mm in the event of an obstruction preventing the 75mm overlap). The overlap should be bonded with a 10mm bead of FS702 Intumastic placed 20-60mm from the board edges, and additionally mechanically restrained using 75mm steel screws with a 25mm washer at maximum 300mm centres, 10-65mm from the board perimeter and no more than 50mm from a board joint. A low torque setting should be used to ensure that the embedment of fixing into the board does not exceed 15mm. The fixings may be left exposed or covered using FS702 Intumastic. The FB750 Intubatt should be installed in as few cut pieces as possible. All joints are to be bonded using FS712 Intucoat to full width of the FB750 Intubatt or FS702 Intumastic applied as a 10mm bead along the full-length joint centre line. FS702 Intumastic should be used to point all service and substrate interfaces, to a minimum of a 6mm bead. Apertures for penetrating services are to be tightly fitted and sealed. Imperfections should be filled with FS702 Intumastic to the full depth of the FB750 Intubatt. Service openings should be cut no more than 15mm away from non-combustible services, and/or, openings should be cut to suit the requirements of any additional required Nullifire product, if the service type is combustible or insulated CS or LS. External sides of the Board may be required to be coated for aesthetic reasons or to prevent fibre migration. (In situations where the required overlap cannot be achieved due to a perpendicular fire resisting wall / soffit, it is possible to reduce the overlap, down to as low as 0mm, provided the board edge is bonded to the adjoining compartment using a 10mm bead of FS702 Intumastic, and subsequently pointed to all mated edges)
The results below are also applicable when using multiple layers of surface mounted FB750 Intubatt. For multiple layers of FB750 Intubatt so a single (or both) face, identically sized boards should be used, ideally with staggered joints where possible. Closing devices should be located in or on the outmost board. Board to board abutment should be bonded with 10mm bead of FS702 Intumastic and mechanically restrained using a 75mm spiral screw to the first and secured layer. Spiral fixings should be at max 200mm centres and no more than 50mm from any joint.

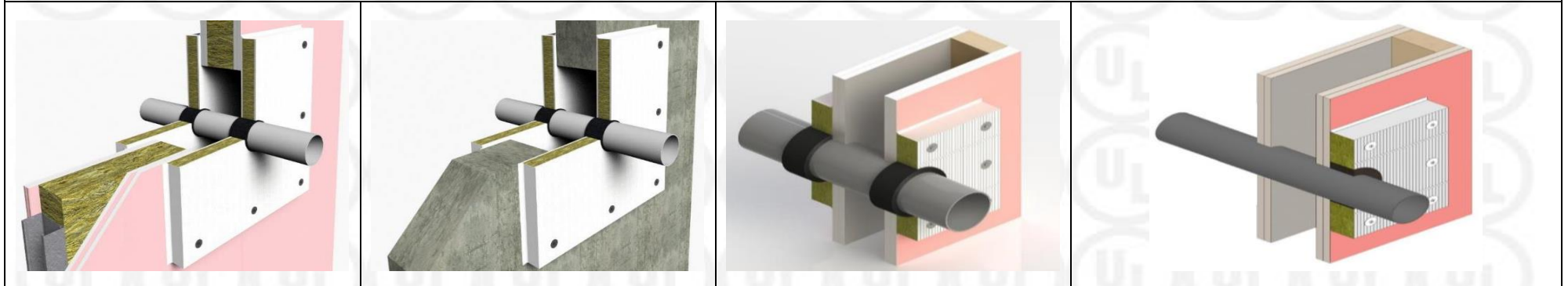

Form-ULID-006104 (DCS:27-CP-F0855) 5.0



Appendix UL-EU CERTIFICATE

Certificate No. UL-EU-01058-CPR
 Page 35/144
 Date of Issue 2017-10-27

Service	Pipe Diameter	Pipe Wall Thickness	Pipe End Configuration		Integrity	Integrity & Insulation	Rigid Wall Thickness (mm)				Flexible Wall Thickness (mm)			Additional Requirements (Both Sides)
	(mm)	(mm)	C/C	U/C	E (mins)	EI (mins)	≥ 145	≥ 130	≥ 100	≥ 90	≥ 130	≥ 100	≥ 90	
HDPE pipe	≤ 110	10,0	✓	✓	120	120	✓	✓	✓	✓	✓	✓	✓	2 layers of FP302 Intustrap central to the seal of both batts and sealed with FS702 Intumastic
PVC-U pipe (+ PVC-C)	≤ 160	3.2	✓	✓	120	120	✓	✓	✓		✓	✓		4 layers of FP302 Intustrap, sealed within FB750 Intubatt with FS702 Intumastic
PVC-U pipe (+ PVC-C)	≤ 110	6.6	✓	✓	120	120	✓	✓			✓			3 layers of FP302 Intustrap, sealed within FB750 Intubatt with FS702 Intumastic
PVC-U pipe (+ PVC-C)	≤ 110	3.2	✓	✓	120	120	✓	✓						3 layers of FP302 Intustrap, sealed within FB750 Intubatt with FS702 Intumastic
PVC-U pipe (+ PVC-C)	≤ 55	2	✓	✓	120	120	✓	✓	✓					1 layer of FP302 Intustrap, sealed within FB750 Intubatt with FS702 Intumastic
PVC-U pipe (+ PVC-C)	≤ 110	4.2	✓	✓	90	90	✓	✓	✓		✓	✓		3 layers of FP302 Intustrap, sealed within FB750 Intubatt with FS702 Intumastic
PVC-U pipe (+ PVC-C)	≤ 110	3.2	✓	✓	90	90	✓	✓	✓		✓	✓		3 layers of FP302 Intustrap, sealed within FB750 Intubatt with FS702 Intumastic
PVC-U pipe (+ PVC-C)	≤ 36	1.8	✓	✓	90	90	✓	✓	✓		✓	✓		1 layer of FP302 Intustrap, sealed within FB750 Intubatt with FS702 Intumastic
PVC-U pipe (+ PVC-C)	(#) ≤ 110	3.2	✓	✓	60	60	✓							3 layers of FP302 Intustrap, sealed within FB750 Intubatt with FS702 Intumastic
PEX multilayer pipe	≤ 69	8,0	✓	✓	120	120	✓	✓	✓	✓	✓	✓	✓	2 layers of FP302 Intustrap central to the seal of both batts and sealed with FS702 Intumastic
PEX multilayer pipe	≤ 111	10,0	✓	✓	120	120	✓	✓	✓	✓	✓	✓	✓	2 layers of FP302 Intustrap central to the seal of both batts and sealed with FS702 Intumastic
PEX multilayer pipe	(*) ≤ 64	12	✓	✓	120	120	✓	✓	✓		✓	✓		20mm annulus of FS709 HP Intumescent Sealant, 50mm depth



Appendix UL-EU CERTIFICATE

Certificate No. UL-EU-01058-CPR

Page 36/144

Date of Issue 2017-10-27

Service	Pipe Diameter	Pipe Wall Thickness	Pipe End Configuration		Integrity	Integrity & Insulation	Rigid Wall Thickness (mm)				Flexible Wall Thickness (mm)			Additional Requirements (Both Sides)
	(mm)	(mm)	C/C	U/C	E (mins)	EI (mins)	≥ 145	≥ 130	≥ 100	≥ 90	≥ 130	≥ 100	≥ 90	
PEX multilayer pipe	≤ 26	3	✓	✓	120	120	✓	✓	✓		✓	✓		25mm annulus of FS709 HP Intumescent Sealant, 25mm depth (using FB750 as backer)
PEX multilayer pipe	(*) ≤ 111	12	✓	✓	120	120	✓	✓	✓		✓	✓		20mm annulus of FS709 HP Intumescent Sealant, 50mm depth
PEX multilayer pipe	≤ 40	4.2	✓	✓	120	120	✓	✓	✓		✓	✓		25mm annulus of FS709 HP Intumescent Sealant, 25mm depth (using FB750 as backer)
PEX multilayer pipe	≤ 21	2.8	✓	✓	120	120	✓	✓	✓		✓	✓		25mm annulus of FS709 HP Intumescent Sealant, 25mm depth (using FB750 as backer)
PEX multilayer pipe	≤ 18	2.8	✓	✓	120	120	✓	✓	✓		✓	✓		25mm annulus of FS709 HP Intumescent Sealant, 25mm depth (using FB750 as backer)
PEX multilayer pipe	≤ 28	2.6	✓	✓	120	120	✓	✓	✓		✓	✓		25mm annulus of FS709 HP Intumescent Sealant, 25mm depth (using FB750 as backer)
≤ 2 banks of 6 PEX multilayer pipes	≤ 28	2.6	✓	✓	120	120	✓	✓	✓		✓	✓		1 layer of FP302 Intustrap around the entire perimeter (not individual pipes), sealed within FB750 Intubatt with FS702 Intumastic
1 stack of 10 PEX multilayer pipes	≤ 28	2.6	✓	✓	120	120	✓	✓	✓		✓	✓		1 layer of FP302 Intustrap around the entire perimeter (not individual pipes), sealed within FB750 Intubatt with FS702 Intumastic
1 bank of 6 PEX multilayer pipes	≤ 28	2.6	✓	✓	60	60	✓	✓	✓		✓	✓		25mm annulus of FS709 HP Intumescent Sealant, 25mm depth (using FB750 as backer)
PPR multilayer pipe	≤ 75	10	✓	✓	120	120	✓	✓	✓		✓	✓		2 layers of FP302 Intustrap, sealed within FB750 Intubatt with FS702 Intumastic
CPVC Lubrizol Pipe	≤ 90 (\$)	7.2	✓	✓	120	120	✓	✓	✓		✓	✓		3 layers of FP302 Intustrap, sealed within FB750 Intubatt with FS702 Intumastic

Form-ULID-006104 (DCS:27-CP-F0855) 5.0



Appendix UL-EU CERTIFICATE

Certificate No. UL-EU-01058-CPR
 Page 37/144
 Date of Issue 2017-10-27

Service	Pipe Diameter (mm)	Pipe Wall Thickness (mm)	Pipe End Configuration		Integrity E (mins)	Integrity & Insulation EI (mins)	Rigid Wall Thickness (mm)				Flexible Wall Thickness (mm)			Additional Requirements (Both Sides)	
			C/C	U/C			≥ 145	≥ 130	≥ 100	≥ 90	≥ 130	≥ 100	≥ 90		
CPVC Lubrizol Pipe	(#)	≤ 34 (\$)	3	✓	✓	60	60	✓							1 layer of FP302 Intustrap, sealed within FB750 Intubatt with FS702 Intumastic
CPVC Lubrizol Pipe	(#)	≤ 34 (\$)	3	✓	✓	60	60	✓							25mm annulus of FS709 HP Intumescent Sealant, 25mm depth (using FB750 as backer)
PE pipe (+ HDPE, ABS, San+ PVC, PVC-U & PVC-C)		≤ 110	3.4	✓	✓	90	90	✓	✓	✓		✓	✓		3 layers of FP302 Intustrap, sealed within FB750 Intubatt with FS702 Intumastic
PP pipe		≤ 110	3.4	✓	✓	90	90	✓	✓	✓		✓	✓		3 layers of FP302 Intustrap, sealed within FB750 Intubatt with FS702 Intumastic

(*) Includes horizontal pipes from 90° to 45° to supporting construction
 (#) Overlap can be reduced from 75mm to 50mm
 (\$) External measurements manually taken from US units specified pipes



Appendix UL-EU CERTIFICATE

Certificate No. UL-EU-01058-CPR
Page 38/144
Date of Issue 2017-10-27

Combustible Pipes – Double Batt Pattress - FP170/FP220

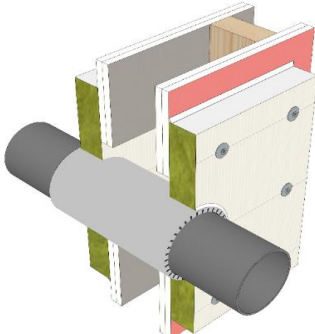
Combustible Pipes Insulated with No insulation passing through Flexible and Rigid Walls as identified below, protected by double pattress (surface mounted) FB750 Intubatt seal, sealed with FS702 Intumastic or FS712 Intucoat.
Wall Details: Flexible or Rigid Walls including Concrete, Brick / Blockwork & AAC, of minimum thickness as identified below, and with performance classified to EN 13501-2. Flexible Walls constructed from steel or timber faced studs with a minimum of 2 x 12.5mm EN 520 type F boards on each side of studs.
Maximum Opening size: 800mm by 550mm. Multiple openings must be separated by a minimum of 200mm for fire resistance requirements. Check separation requirements with the system owner of the supporting construction.
Installation Instructions: Boards surface mounted (pattress fit) on both sides of the wall with a minimum 75mm overlap around the opening. (Overlap on the lowest edge can be reduced to 30mm in the event of an obstruction preventing the 75mm overlap). The overlap should be bonded with a 10mm bead of FS702 Intumastic placed 20-60mm from the board edges, and additionally mechanically restrained using 75mm steel screws with a 25mm washer at maximum 300mm centres, 10-65mm from the board perimeter and no more than 50mm from a board joint. A low torque setting should be used to ensure that the embedment of fixing into the board does not exceed 15mm. The fixings may be left exposed or covered using FS702 Intumastic. The FB750 Intubatt should be installed in as few cut pieces as possible. All joints are to be bonded using FS712 Intucoat to full width of the FB750 Intubatt or FS702 Intumastic applied as a 10mm bead along the full-length joint centre line. FS702 Intumastic should be used to point all service and substrate interfaces, to a minimum of a 6mm bead. Apertures for penetrating services are to be tightly fitted and sealed. Imperfections should be filled with FS702 Intumastic to the full depth of the FB750 Intubatt. Service openings should be cut no more than 15mm away from non-combustible services, and/or, openings should be cut to suit the requirements of any additional required Nullifire product, if the service type is combustible or insulated CS or LS. External sides of the Board may be required to be coated for aesthetic reasons or to prevent fibre migration. (In situations where the required overlap cannot be achieved due to a perpendicular fire resisting wall / soffit, it is possible to reduce the overlap, down to as low as 0mm, provided the board edge is bonded to the adjoining compartment using a 10mm bead of FS702 Intumastic, and subsequently pointed to all mated edges)
The results below are also applicable when using multiple layers of surface mounted FB750 Intubatt. For multiple layers of FB750 Intubatt so a single (or both) face, identically sized boards should be used, ideally with staggered joints where possible. Closing devices should be located in or on the outmost board. Board to board abutment should be bonded with 10mm bead of FS702 Intumastic and mechanically restrained using a 75mm spiral screw to the first and secured layer. Spiral fixings should be at max 200mm centres and no more than 50mm from any joint.

Form-ULID-006104 (DCS:27-CP-F0855) 5.0



Appendix UL-EU CERTIFICATE

Certificate No. UL-EU-01058-CPR
 Page 39/144
 Date of Issue 2017-10-27

Service	Pipe Diameter (mm)	Pipe Wall Thickness (mm)	Pipe End Configuration				Integrity		Integrity & Insulation		Rigid Wall Thickness (mm)	Flexible Wall Thickness (mm)	Additional Requirements (Both Sides)
			C/C	U/C	C/U	U/U	E (mins)	EI (mins)	≥ 100	≥ 100			
PP-MD pipe (*)	≤ 50	2	✓	✓	✓	✓	120	120	✓	✓	✓	✓	FP220 Service Sleeve Ø55 x 220mm (central to the seal) within the FB750 Intubatt, sealed with 3mm deep FS709 HP Intumastic Sealant
PP-MD pipe	≤ 50	2	✓	✓	✓	✓	120	120	✓	✓	✓	✓	FP170 Intucollar Ø55mm, sealed with FS702 Intumastic
PP pipe	≤ 160	14.6	✓	✓	✓	✓ (#)	120	120	✓	✓	✓	✓	FP220 Service Sleeve Ø192 x 220mm (central to the seal) within the FB750 Intubatt, sealed with FS702 Intumastic
PP pipe	≤ 75	7.6	✓	✓	✓	✓	120	120	✓	✓	✓	✓	FP220 Service Sleeve Ø87 x 220mm (central to the seal) within the FB750 Intubatt, sealed with FS702 Intumastic
PP pipe	≤ 50	2.2	✓	✓	✓	✓	120	120	✓	✓	✓	✓	FP220 Service Sleeve Ø62 x 220mm (central to the seal) within the FB750 Intubatt, sealed with FS702 Intumastic
PP pipe	≤ 110	3.4	✓	✓	✓	✓	120	120	✓	✓	✓	✓	FP220 Service Sleeve Ø130 x 220mm (central to the seal) within the FB750 Intubatt, sealed with FS702 Intumastic
PP pipe	≤ 75	7.1	✓	✓	✓	✓	120	120	✓	✓	✓	✓	FP220 Service Sleeve Ø94 x 220mm (central to the seal) within the FB750 Intubatt, sealed with FS702 Intumastic
PP pipe	≤ 110	2.4	✓	✓	✓	✓	120	120	✓	✓	✓	✓	FP170 Intucollar Ø110mm, sealed with FS702 Intumastic
PP pipe	≤ 75	7.2	✓	✓	✓	✓	120	30	✓	✓	✓	✓	FP170 Intucollar Ø82mm, sealed with FS702 Intumastic
PE pipe (+ ABS, San+ PVC, PVC-U & PVC-C)	≤ 160	5.4	✓	✓	✓	✓	120	120	✓	✓	✓	✓	FP220 Service Sleeve Ø192 x 220mm (central to the seal) within the FB750 Intubatt, sealed with FS702 Intumastic



Appendix UL-EU CERTIFICATE

Certificate No. UL-EU-01058-CPR
 Page 40/144
 Date of Issue 2017-10-27

Service	Pipe Diameter	Pipe Wall Thickness	Pipe End Configuration				Integrity	Integrity & Insulation	Rigid Wall Thickness (mm)	Flexible Wall Thickness (mm)	Additional Requirements (Both Sides)
	(mm)	(mm)	C/C	U/C	C/U	U/U	E (mins)	EI (mins)	≥ 100	≥ 100	
PE pipe (+ ABS, San+ PVC, PVC-U & PVC-C)	≤ 110	4.2	✓	✓	✓	✓	120	120	✓	✓	FP220 Service Sleeve Ø130 x 220mm (central to the seal) within the FB750 Intubatt, sealed with FS702 Intumastic
PE pipe (+ ABS, San+ PVC, PVC-U & PVC-C)	≤ 110	11	✓	✓	✓	✓	120	120	✓	✓	FP220 Service Sleeve Ø130 x 220mm (central to the seal) within the FB750 Intubatt, sealed with FS702 Intumastic

(#)Pipe end configuration U/U up to 79 minutes only



Appendix UL-EU CERTIFICATE

Certificate No. UL-EU-01058-CPR
 Page 41/144
 Date of Issue 2017-10-27

Service	Pipe Diameter	Pipe Wall Thickness	Pipe End Configuration				Integrity	Integrity & Insulation	Rigid Wall Thickness (mm)	Flexible Wall Thickness (mm)	Additional Requirements (Both Sides)
	(mm)	(mm)	C/C	U/C	C/U	U/U	E (mins)	EI (mins)	≥ 100	≥ 100	
PVC-U pipe (+ PVC-C)	≤ 82	3.1	✓	✓	✓	✓	120	120	✓	✓	FP220 Service Sleeve Ø94 x 220mm (central to the seal) within the FB750 Intubatt, sealed with FS702 Intumastic
PVC-U pipe (+ PVC-C)	≤ 80	10.6	✓	✓	✓	✓	120	120	✓	✓	FP220 Service Sleeve Ø94 x 220mm (central to the seal) within the FB750 Intubatt, sealed with FS702 Intumastic
PVC-U pipe (+ PVC-C)	≤ 50	2.4	✓	✓	✓	✓	120	120	✓	✓	FP220 Service Sleeve Ø62 x 220mm (central to the seal) within the FB750 Intubatt, sealed with FS702 Intumastic
PVC-U pipe (+ PVC-C)	≤ 50	2.6	✓	✓	✓	✓	120	120	✓	✓	FP170 Intucollar Ø55mm, sealed with FS702 Intumastic
PVC-U pipe (+ PVC-C)	(*) ≤ 110	2.4	✓	✓	✓	✓	90	60	✓	✓	FP220 Service Sleeve Ø130 x 220mm (central to the seal) within the FB750 Intubatt, sealed with FS702 Intumastic
PVC-U pipe (+ PVC-C)	≤ 82	3.2	✓	✓	✓	✓	60	60	✓	✓	FP220 Service Sleeve Ø94 x 220mm (central to the seal) within the FB750 Intubatt, sealed with FS702 Intumastic
PVC-U pipe (+ PVC-C)	≤ 82	3.2	✓	✓	✓	✓	60	60	✓	✓	FP170 Intucollar Ø82mm, sealed with FS702 Intumastic
PVC rectangular pipe	220x90	1.5	✓	✓	✓	✓	120	120	✓	✓	FP220 Service Sleeve 220x90x220mm (central to the seal) within the FB750 Intubatt, sealed with FS702 Intumastic
PVC rectangular pipe	204x60	1.5	✓	✓	✓	✓	90	90	✓	✓	FP220 Service Sleeve 204x60x220mm (central to the seal) within the FB750 Intubatt, sealed with FS702 Intumastic
PE-RT multilayer pipe	(*) ≤ 40	4	✓	✓			120	15	✓	✓	FP220 Service Sleeve Ø55 x 220mm (central to the seal) within the FB750 Intubatt, sealed with 3mm deep FS709 HP Intumastic Sealant

(*) Includes horizontal pipes from 90° to 45° to supporting construction



Appendix UL-EU CERTIFICATE

Certificate No. UL-EU-01058-CPR
Page 42/144
Date of Issue 2017-10-27

Combustible Pipes – Double Batt Compression - FS709/FP302

Uninsulated Combustible Pipes passing through Flexible and Rigid Walls as identified below, protected by double compressed FB750 Intubatt seal, sealed with FS702 Intumastic or FS712 Intucoat.

Wall Details: Flexible or Rigid Walls including Concrete, Brick / Blockwork & AAC, of minimum thickness as identified below, and with performance classified to EN 13501-2.
Flexible Walls constructed from steel or timber faced studs with a minimum of 2x12.5mm EN 520 type F boards on each side of studs.

Maximum Opening size: 800mm by 550mm. In Flexible Walls openings should be created using a steel frame. Multiple openings must be separated by a minimum of 200mm for fire resistance requirements. Check separation requirements with the system owner of the supporting construction.

Installation Instructions: Double Layer board, compressed and bonded into the aperture outer face flush with the face of the supporting construction. FB750 Intubatt should be installed in as few cut pieces as possible and tightly compressed to two opposite sides. This is achieved by the addition of 2mm to the required cut dimension. Compression may be applied - FB750 Intubatt to FB750 Intubatt, FB750 Intubatt to non-combustible service, or FB750 Intubatt to Substrate. Compression must be achieved over a minimum 60% of the FB750 Intubatt compressed edge. If compression is achieved Top to bottom of FB750 Intubatt, left/right is not required to be compressed and vice versa (the non-compressed seal should be fully abutted and bonded). All joints are to be bonded using FS712 Intucoat to full width of the FB750 Intubatt or FS702 Intumastic applied as a 10mm bead along the full-length joint centre line. FS702 Intumastic should be used to point all service and substrate interfaces, to a minimum of a 6mm bead. Apertures for penetrating services are to be tightly fitted and sealed. Imperfections should be filled with FS702 Intumastic to the full depth of the FB750 Intubatt. Service openings should be cut no more than 15mm away from non-combustible services, and/or, openings should be cut to suit the requirements of any additional required Nullifire product, if the service type is combustible or insulated CS or LS. (Imperfections in cut on a compressed edge may not exceed 40% of the area available to receive compression)

The results below are also applicable when using multiple layers of FB750 Intubatt, including 1 layer (or more) surface mounted on both sides of the wall.

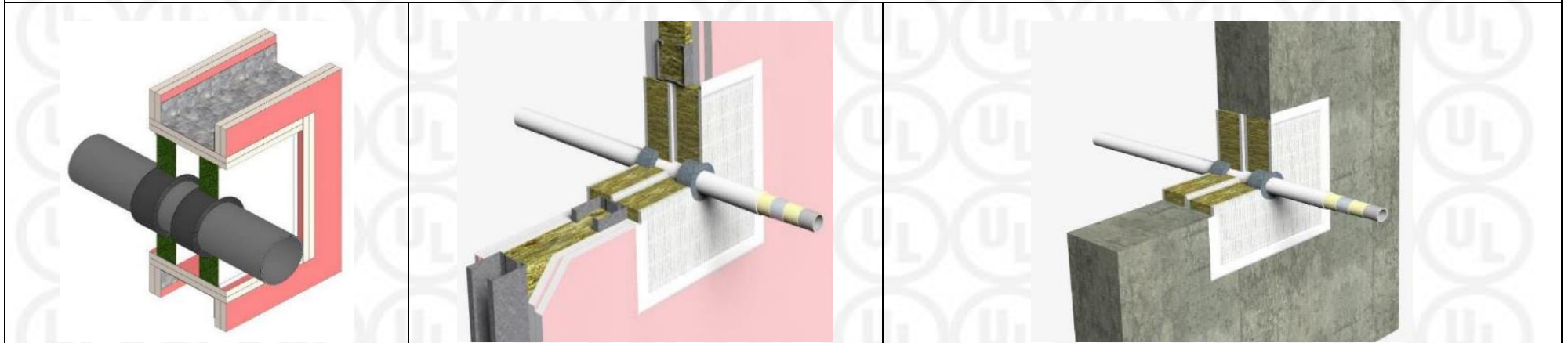

Form-ULID-006104 (DCS:27-CP-F0855) 5.0



Appendix UL-EU CERTIFICATE

Certificate No. UL-EU-01058-CPR
 Page 43/144
 Date of Issue 2017-10-27

Service	Pipe Diameter	Pipe Wall Thickness	Pipe End Configuration		Integrity	Integrity & Insulation		Rigid Wall Thickness (mm)		Flexible Wall Thickness (mm)	Additional Requirements (Both Sides)
	(mm)	(mm)	C/C	U/C	E (mins)	EI (mins)	≥ 145	≥ 100	≥ 100		
CPVC Lubrizol pipe	≤ 90	7.2	✓	✓	120	120	✓	✓	✓	3 layers of FP302 Intustrap, sealed within FB750 Intubatt with FS702 Intumastic	
PVC-U pipe (+ PVC-C)	≤ 160	3.2	✓	✓	120	120	✓	✓	✓	4 layers of FP302 Intustrap, sealed within FB750 Intubatt with FS702 Intumastic	
PVC-U pipe (+ PVC-C)	≤ 55	2	✓	✓	120	120	✓	✓		1 layer of FP302 Intustrap, sealed within FB750 Intubatt with FS702 Intumastic	
PVC-U pipe (+ PVC-C)	≤ 110	3.2	✓	✓	120	120	✓			3 layers of FP302 Intustrap, sealed within FB750 Intubatt with FS702 Intumastic	
PVC-U pipe (+ PVC-C)	≤ 110	4.2	✓	✓	90	90	✓	✓	✓	3 layers of FP302 Intustrap, sealed within FB750 Intubatt with FS702 Intumastic	
PPR multilayer pipe	≤ 75	10	✓	✓	120	120	✓	✓	✓	2 layers of FP302 Intustrap, sealed within FB750 Intubatt with FS702 Intumastic	
PEX multilayer pipe	(*) ≤ 64	12	✓	✓	120	120	✓	✓	✓	20mm annulus of FS709 HP Intumescent Sealant, 50mm depth	
PEX multilayer pipe	(*) ≤ 111	12	✓	✓	120	120	✓	✓	✓	20mm annulus of FS709 HP Intumescent Sealant, 50mm depth	
PEX multilayer pipe	≤ 28	2.6	✓	✓	90	90	✓	✓	✓	25mm annulus of FS709 HP Intumescent Sealant, 25mm depth (using FB750 as backer)	
1 bank of 6 PEX multilayer pipes	≤ 28	2.6	✓	✓	60	60	✓	✓	✓	25mm annulus of FS709 HP Intumescent Sealant, 25mm depth (using FB750 as backer)	



Appendix UL-EU CERTIFICATE

Certificate No. UL-EU-01058-CPR
 Page 44/144
 Date of Issue 2017-10-27

Service	Pipe Diameter	Pipe Wall Thickness	Pipe End Configuration		Integrity	Integrity & Insulation		Rigid Wall Thickness (mm)		Flexible Wall Thickness (mm)	Additional Requirements (Both Sides)
	(mm)	(mm)	C/C	U/C	E (mins)	EI (mins)	≥ 145	≥ 100	≥ 100		
PE pipe (+ ABS, San+ PVC, PVC-U & PVC-C)	≤ 110	3.4	✓	✓	90	90	✓	✓	✓	3 layers of FP302 Intustrap, sealed within FB750 Intubatt with FS702 Intumastic	
PP pipe	≤ 110	3.4	✓	✓	90	90	✓	✓	✓	3 layers of FP302 Intustrap, sealed within FB750 Intubatt with FS702 Intumastic	

(*) Includes horizontal pipes from 90° to 45° to supporting construction



Appendix UL-EU CERTIFICATE

Certificate No. UL-EU-01058-CPR
Page 45/144
Date of Issue 2017-10-27

Combustible Pipes Double Batt Compression - FP170/FP220

Uninsulated Combustible Pipes passing through Flexible and Rigid Walls as identified below, protected by double compressed FB750 Intubatt seal, sealed with FS702 Intumastic or FS712 Intucoat.

Wall Details: Flexible or Rigid Walls including Concrete, Brick / Blockwork & AAC, of minimum thickness as identified below, and with performance classified to EN 13501-2.
Flexible Walls constructed from steel or timber faced studs with a minimum of 2 x 12.5mm EN 520 type F boards on each side of studs.

Maximum Opening size: 800mm by 550mm. In Flexible Walls openings should be created using a steel frame. Multiple openings must be separated by a minimum of 200mm for fire resistance requirements. Check separation requirements with the system owner of the supporting construction.

Installation Instructions: Double Layer board, compressed and bonded into the aperture outer face flush with the face of the supporting construction. FB750 Intubatt should be installed in as few cut pieces as possible and tightly compressed to two opposite sides. This is achieved by the addition of 2mm to the required cut dimension. Compression may be applied - FB750 Intubatt to FB750 Intubatt, FB750 Intubatt to non-combustible service, or FB750 Intubatt to Substrate. Compression must be achieved over a minimum 60% of the FB750 Intubatt compressed edge. If compression is achieved Top to bottom of FB750 Intubatt, left/right is not required to be compressed and vice versa (the non-compressed seal should be fully abutted and bonded). All joints are to be bonded using FS712 Intucoat to full width of the FB750 Intubatt or FS702 Intumastic applied as a 10mm bead along the full-length joint centre line. FS702 Intumastic should be used to point all service and substrate interfaces, to a minimum of a 6mm bead. Apertures for penetrating services are to be tightly fitted and sealed. Imperfections should be filled with FS702 Intumastic to the full depth of the FB750 Intubatt. Service openings should be cut no more than 15mm away from non-combustible services, and/or, openings should be cut to suit the requirements of any additional required Nullifire product, if the service type is combustible or insulated CS or LS. (Imperfections in cut on a compressed edge may not exceed 40% of the area available to receive compression)

The results below are also applicable when using multiple layers of FB750 Intubatt, including 1 layer (or more) surface mounted on both sides of the wall.

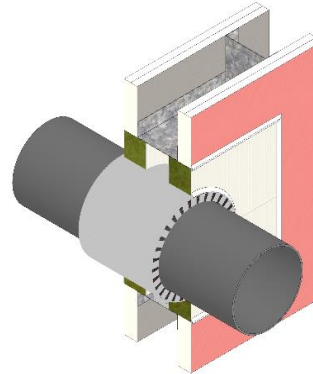

Form-ULID-006104 (DCS:27-CP-F0855) 5.0



Appendix UL-EU CERTIFICATE

Certificate No. UL-EU-01058-CPR
 Page 46/144
 Date of Issue 2017-10-27

Service	Pipe Diameter (mm)	Pipe wall Thickness (mm)	Pipe End Configuration				Integrity E (mins)	Integrity & Insulation EI (mins)	Rigid Wall Thickness (mm) ≥ 100	Flexible Wall Thickness (mm) ≥ 100	Additional Requirements (Both Sides)
			C/C	U/C	C/U	U/U					
PP-MD pipe (*)	≤ 50	2	✓	✓	✓	✓	120	120	✓	✓	FP220 Service Sleeve Ø≤ 55 x 220mm (central to the seal) within the FB750 Intubatt, sealed with 3mm deep FS709 HP Intumastic Sealant
PP-MD pipe	≤ 50	2	✓	✓	✓	✓	120	120	✓	✓	FP170 Intucollar Ø≤ 55mm, sealed with FS702 Intumastic
PE pipe (+ HDPE, ABS, San+ PVC, PVC-U & PVC-C)	≤ 160	5	✓	✓	✓	✓	120	120	✓	✓	FP220 Service Sleeve Ø192 x 220mm (central to the seal) within the FB750 Intubatt, sealed with FS702 Intumastic
PE pipe (+ HDPE, ABS, San+ PVC, PVC-U & PVC-C)	≤ 110	4	✓	✓	✓	✓	120	120	✓	✓	FP220 Service Sleeve Ø130 x 220mm (central to the seal) within the FB750 Intubatt, sealed with FS702 Intumastic
PVC-U pipe (+ PVC-C)	≤ 82	3	✓	✓	✓	✓	120	120	✓	✓	FP220 Service Sleeve Ø94 x 220mm (central to the seal) within the FB750 Intubatt, sealed with FS702 Intumastic
PVC-U pipe (+ PVC-C)	≤ 50	2	✓	✓	✓	✓	120	120	✓	✓	FP220 Service Sleeve Ø62 x 220mm (central to the seal) within the FB750 Intubatt, sealed with FS702 Intumastic
PVC-U pipe (+ PVC-C)	≤ 50	3	✓	✓	✓	✓	120	120	✓	✓	FP170 Intucollar Ø≤ 55mm, sealed with FS702 Intumastic
PVC-U pipe (+ PVC-C) (*)	≤ 110	2	✓	✓	✓	✓	90	60	✓	✓	FP220 Service Sleeve Ø130 x 220mm (central to the seal) within the FB750 Intubatt, sealed with FS702 Intumastic
PVC-U pipe (+ PVC-C)	≤ 82	3.2	✓	✓	✓	✓	60	60	✓	✓	FP220 Service Sleeve Ø94 x 220mm (central to the seal) within the FB750 Intubatt, sealed with FS702 Intumastic
PVC-U pipe (+ PVC-C)	≤ 82	3.2	✓	✓	✓	✓	60	60	✓	✓	FP170 Intucollar Ø82mm, sealed with FS702 Intumastic
PP pipe	≤ 160	15	✓	✓	✓	✓	120	120	✓	✓	FP220 Service Sleeve Ø192 x 220mm (central to the seal) within the FB750 Intubatt, sealed with FS702 Intumastic
PP pipe	≤ 75	8	✓	✓	✓	✓	120	120	✓	✓	FP220 Service Sleeve Ø87 x 220mm (central to the seal) within the FB750 Intubatt, sealed with FS702 Intumastic
PP pipe	≤ 110	2	✓	✓	✓	✓	120	120	✓	✓	FP170 Intucollar Ø≤ 110mm, sealed with FS702 Intumastic
PP pipe	≤ 75	7	✓	✓	✓	✓	120	30	✓	✓	FP170 Intucollar Ø82mm, sealed with FS702 Intumastic



Appendix UL-EU CERTIFICATE

Certificate No. UL-EU-01058-CPR
 Page 47/144
 Date of Issue 2017-10-27

Service	Pipe Diameter	Pipe wall Thickness	Pipe End Configuration				Integrity	Integrity & Insulation	Rigid Wall Thickness (mm)	Flexible Wall Thickness (mm)	Additional Requirements (Both Sides)
	(mm)	(mm)	C/C	U/C	C/U	U/U	E (mins)	EI (mins)	≥ 100	≥ 100	
PVC rectangular pipe	204x60	2	✓	✓	✓	✓	90	90	✓	✓	FP220 Service Sleeve Ø92 x 236mm (central to the seal) within the FB750 Intubatt, sealed with FS702 Intumastic
PE-RT multilayer pipe	(*) ≤ 40	4	✓	✓			120	15	✓	✓	FP220 Service Sleeve Ø≤ 55 x 220mm (central to the seal) within the FB750 Intubatt, sealed with 3mm deep FS709 HP Intumastic Sealant

(*) Includes horizontal pipes from 90° to 45° to supporting construction



Appendix UL-EU CERTIFICATE

Certificate No. UL-EU-01058-CPR
Page 48/144
Date of Issue 2017-10-27

Combustible Pipes - Single Batt Compression

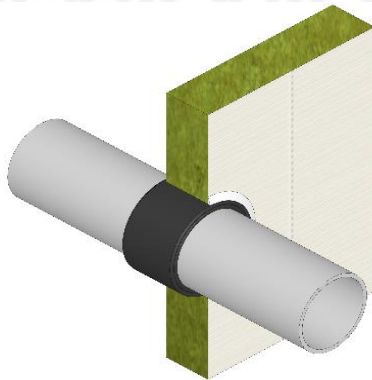
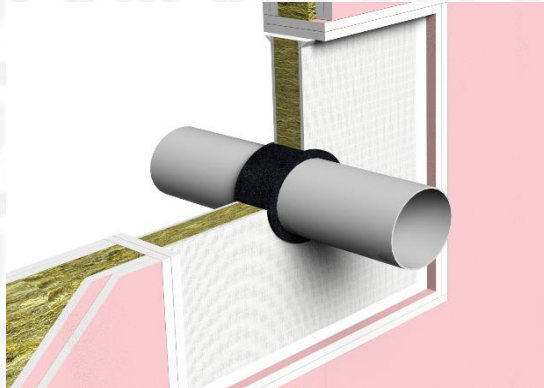
Uninsulated Combustible Pipes passing through Flexible and Rigid Walls as identified below, protected by single compressed FB750 Intubatt seal, sealed with FS702 Intumastic or FS712 Intucoat.	
Wall Details: Flexible or Rigid Walls including Concrete, Brick / Blockwork & AAC, of minimum thickness as identified below, and with performance classified to EN 13501-2. Flexible Walls constructed from steel or timber faced studs with a minimum of 2x12.5mm EN 520 type F boards on each side of studs.	
Maximum Opening size: 500mm by 550mm. In Flexible Walls openings should be created using a steel frame with a plasterboard lining. Multiple openings must be separated by a minimum of 200mm for fire resistance requirements. Check separation requirements with the system owner of the supporting construction.	
Installation Instructions: Single Layer board, compressed and bonded into the aperture at mid depth of the wall. FB750 Intubatt should be installed in as few cut pieces as possible and tightly compressed to two opposite sides. This is achieved by the addition of 2mm to the required cut dimension. Compression may be applied - FB750 Intubatt to FB750 Intubatt, FB750 Intubatt to non-combustible service, or FB750 Intubatt to Substrate. Compression must be achieved over a minimum 60% of the FB750 Intubatt Compressed edge. If compression is achieved Top to bottom of FB750 Intubatt, left/right is not required to be compressed and vice versa (the non-compressed seal should be fully abutted and bonded). All joints are to be bonded using FS712 Intucoat to full width of the FB750 Intubatt or FS702 Intumastic applied as a 10mm bead along the full-length joint centre line. FS702 Intumastic should be used to point all service and substrate interfaces, to a minimum of a 6mm bead. Apertures for penetrating services are to be tightly fitted and sealed. Imperfections should be filled with FS702 Intumastic to the full depth of the FB750 Intubatt. Service openings should be cut no more than 15mm away from non-combustible services, and/or, openings should be cut to suit the requirements of any additional required Nullfire product, if the service type is combustible or insulated CS or LS. (Imperfections in cut on a compressed edge may not exceed 40% of the area available to receive compression)	
The results below are also applicable when using multiple layers of FB750 Intubatt, including 1 layer (or more) surface mounted on both sides of the wall.	
	

Form-ULID-006104 (DCS:27-CP-F0855) 5.0



Appendix UL-EU CERTIFICATE

Certificate No. UL-EU-01058-CPR
 Page 49/144
 Date of Issue 2017-10-27

Service	Pipe Diameter	Pipe Wall Thickness	Pipe End Configuration		Integrity	Integrity & Insulation	Rigid Wall Thickness (mm)	Flexible Wall Thickness (mm)	Additional Requirements
	(mm)	(mm)	C/C	U/C	E (mins)	EI (mins)	≥ 100	≥ 100	
PVC-U pipe (+ PVC-C)	≤ 110	4.2	✓	✓	90	60	✓		3 layers of FP302 Intustrap (central to the seal), sealed on both sides of FB750 Intubatt with FS702 Intumastic
PVC-U pipe (+ PVC-C)	≤ 110	3.5	✓	✓	90	30	✓	✓	3 layers of FP302 Intustrap (central to the seal), sealed on both sides of FB750 Intubatt with FS702 Intumastic



Appendix UL-EU CERTIFICATE

Certificate No. UL-EU-01058-CPR
Page 50/144
Date of Issue 2017-10-27

Combustible Pipes - Single Batt Compression (Asymmetric)

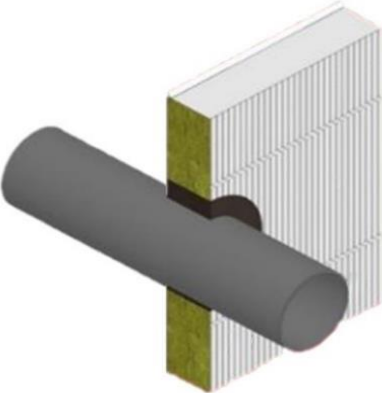
Uninsulated Combustible Pipes passing through Flexible and Rigid Walls as identified below, protected by single compressed asymmetric FB750 Intubatt seal, sealed with FS702 Intumastic or FS712 Intucoat.
Wall Details: Flexible or Rigid Walls including Concrete, Brick / Blockwork & AAC, of minimum thickness as identified below, and with performance classified to EN 13501-2. Flexible Walls constructed from steel or timber faced studs with a minimum of 2x12.5mm EN 520 type F boards on each side of studs.
Maximum Opening size: 500mm by 550mm. In Flexible Walls openings should be created using a steel frame with a plasterboard lining. Multiple openings must be separated by a minimum of 200mm for fire resistance requirements. Check separation requirements with the system owner of the supporting construction.
Installation Instructions: Single Layer board, compressed and bonded into the aperture on the opposite side of the wall to fire. FB750 Intubatt should be installed in as few cut pieces as possible and tightly compressed to two opposite sides. This is achieved by the addition of 2mm to the required cut dimension. Compression may be applied - FB750 Intubatt to FB750 Intubatt, FB750 Intubatt to non-combustible service, or FB750 Intubatt to Substrate. Compression must be achieved over a minimum 60% of the FB750 Intubatt compressed edge. If compression is achieved Top to bottom of FB750 Intubatt, left/right is not required to be compressed and vice versa (the non-compressed seal should be fully abutted and bonded). All joints are to be bonded using FS712 Intucoat to full width of the FB750 Intubatt or FS702 Intumastic applied as a 10mm bead along the full-length joint centre line. FS702 Intumastic should be used to point all service and substrate interfaces, to a minimum of a 6mm bead. Apertures for penetrating services are to be tightly fitted and sealed. Imperfections should be filled with FS702 Intumastic to the full depth of the FB750 Intubatt. Service openings should be cut no more than 15mm away from non-combustible services, and/or, openings should be cut to suit the requirements of any additional required Nullfire product, if the service type is combustible or insulated CS or LS. (Imperfections in cut on a compressed edge may not exceed 40% of the area available to receive compression)
The results below are also applicable when using multiple layers of FB750 Intubatt, including one layer or more of surface mounted FB750 Intubatt.

Form-ULID-006104 (DCS:27-CP-F0855) 5.0



Appendix UL-EU CERTIFICATE

Certificate No. UL-EU-01058-CPR
 Page 51/144
 Date of Issue 2017-10-27

Service	Pipe Diameter	Pipe Wall Thickness	Pipe End Configuration		Integrity	Integrity & Insulation	Rigid Wall Thickness (mm)	Flexible Wall Thickness (mm)	Additional Requirements
	(mm)	(mm)	C/C	U/C	E (mins)	EI (mins)	≥ 100	≥ 100	
PEX multilayer pipe (*)	≤ 111	12	✓	✓	60	60	✓	✓	20mm annulus of FS709 HP Intumescent Sealant, 50mm depth



Appendix UL-EU CERTIFICATE

Certificate No. UL-EU-01058-CPR
Page 52/144
Date of Issue 2017-10-27

Combustible Pipes in Shafts – Double Batt Pattress & Compression

<p>Combustible Pipes through Flexible and Rigid Shaft Walls as identified below, protected by double FB750 Intubatt seal, requiring access from one side only to construct. The first batt is installed flush with the surface furthest from the installation side. The second batt is surface mounted on the installation side, sealed with FS702 Intumastic or FS712 Intucoat. Results apply for fire in either direction.</p>
<p>Wall Details: Flexible or Rigid Walls including Concrete, Brick / Blockwork & AAC, of minimum thickness as identified below, and with performance classified to EN 13501-2. Flexible Walls constructed from steel or studs with a minimum of 1x19mm EN 520 type F board on the far side, and 2x15mm EN 520 type F boards on the installation side of the studs.</p>
<p>Maximum Opening size: 2010mm by 1000mm. Multiple openings must be separated by a minimum of 200mm for fire resistance requirements. Check separation requirements with the system owner of the supporting construction.</p>
<p>Installation Instructions: A 10mm bead of FS702 should be applied to the perimeter of the opening at the furthest point. The first board is then compressed, bonded and located on the perimeter bead, within the opening. This FB750 Intubatt should be installed in as few cut pieces as possible and tightly compressed to two opposite sides. This is achieved by the addition of 2mm to the required cut dimension. Compression may be applied - FB750 Intubatt to FB750 Intubatt, FB750 Intubatt to non-combustible service, or FB750 Intubatt to Substrate. Compression must be achieved over a minimum 60% of the FB750 Intubatt Compressed edge. If compression of FB750 Intubatt is achieved between two opposite sides, the perpendicular sides are not required to be compressed (the non-compressed seal should be fully abutted and bonded). All joints are to be bonded using FS712 Intucoat to full width of the FB750 Intubatt or FS702 Intumastic applied as a 10mm bead along the full-length joint centre line. The second board is surface mounted on installation side of the wall with a minimum 75mm overlap around the opening. (Overlap on the lowest edge can be reduced to 30mm in the event of an obstruction preventing the 75mm overlap). The overlap should be bonded with a 10mm bead of FS702 Intumastic placed 20-60mm from the board edges, and additionally mechanically restrained using 75mm steel screws with a 25mm washer at maximum 300mm centres, 10-65mm from the board perimeter and no more than 50mm from a board joint. A low torque setting should be used to ensure that the embedment of fixing into the board does not exceed 15mm. The fixings may be left exposed or covered using FS702 Intumastic. This FB750 Intubatt should also be installed in as few cut pieces as possible. All joints are to be bonded using FS712 Intucoat to full width of the FB750 Intubatt or FS702 Intumastic applied as a 10mm bead along the full-length joint centre line. FS702 Intumastic should be used to point all service and substrate interfaces, to a minimum of a 6mm bead. Apertures for penetrating services are to be tightly fitted and sealed. Imperfections should be filled with FS702 Intumastic to the full depth of the FB750 Intubatt. Service openings should be cut no more than 15mm away from non-combustible services, and/or, openings should be cut to suit the requirements of any additional required Nullifire product, if the service type is combustible or insulated CS or LS. External sides of the Board may be required to be coated for aesthetic reasons or to prevent fibre migration. (In situations where the required overlap cannot be achieved due to a perpendicular fire resisting wall / soffit, it is possible to reduce the overlap, down to as low as 0mm, provided the board edge is bonded to the adjoining compartment using a 10mm bead of FS702 Intumastic, and subsequently pointed to all mated edges)</p>
<p>The results below are also applicable when using multiple layers of surface mounted FB750 Intubatt. For multiple layers of FB750 Intubatt so a single (or both) face, identically sized boards should be used, ideally with staggered joints where possible. Closing devices should be located in or on the outmost board. Board to board abutment should be bonded with 10mm bead of FS702 Intumastic and mechanically restrained using a 75mm spiral screw to the first and secured layer. Spiral fixings should be at max 200mm centres and no more than 50mm from any joint.</p>

Form-ULID-006104 (DCS:27-CP-F0855) 5.0



Appendix UL-EU CERTIFICATE

Certificate No. UL-EU-01058-CPR

Page 53/144

Date of Issue 2017-10-27

Service	Pipe Diameter	Pipe Wall Thickness	Pipe End Configuration		Integrity	Integrity & Insulation	Flexible Asymmetric Shaft Wall Thickness (mm)	Additional Requirements
	(mm)	(mm)	C/C	U/C	E (mins)	EI (mins)	≥ 90	
HDPE pipe	≤ 110	10,0	✓	✓	120	120	✓	2 layers of FP302 Intustrap central to the seal of both batts and sealed with FS702 Intumastic
PEX multilayer pipe	≤ 69	8,0	✓	✓	120	120	✓	2 layers of FP302 Intustrap central to the seal of both batts and sealed with FS702 Intumastic
PEX multilayer pipe	≤ 111	10,0	✓	✓	120	120	✓	2 layers of FP302 Intustrap central to the seal of both batts and sealed with FS702 Intumastic



Appendix UL-EU CERTIFICATE

Certificate No. UL-EU-01058-CPR
Page 54/144
Date of Issue 2017-10-27

Combustible Pipes Insulated CS – Double Batt Pattress

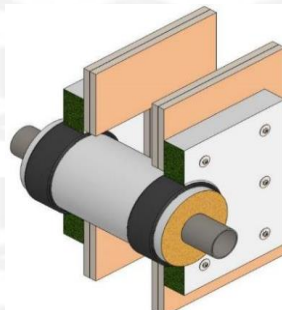
Combustible Pipes Insulated with Continuous Sustained insulation passing through Flexible and Rigid Walls as identified below, protected by double pattress (surface mounted) FB750 Intubatt seal, sealed with FS702 Intumastic or FS712 Intucoat.
Wall Details: Flexible or Rigid Walls including Concrete, Brick / Blockwork & AAC, of minimum thickness as identified below, and with performance classified to EN 13501-2. Flexible Walls constructed from steel or timber faced studs with a minimum of 2x12.5mm EN 520 type F boards on each side of studs.
Maximum Opening size: 900mm by 550mm. Multiple openings must be separated by a minimum of 200mm for fire resistance requirements. Check separation requirements with the system owner of the supporting construction.
Installation Instructions: Boards surface mounted (pattress fit) on both sides of the wall with a minimum 75mm overlap around the opening. (Overlap on the lowest edge can be reduced to 30mm in the event of an obstruction preventing the 75mm overlap). The overlap should be bonded with a 10mm bead of FS702 Intumastic placed 20-60mm from the board edges, and additionally mechanically restrained using 75mm steel screws with a 25mm washer at maximum 300mm centres, 10-65mm from the board perimeter and no more than 50mm from a board joint. A low torque setting should be used to ensure that the embedment of fixing into the board does not exceed 15mm. The fixings may be left exposed or covered using FS702 Intumastic. The FB750 Intubatt should be installed in as few cut pieces as possible. All joints are to be bonded using FS712 Intucoat to full width of the FB750 Intubatt or FS702 Intumastic applied as a 10mm bead along the full-length joint centre line. FS702 Intumastic should be used to point all service and substrate interfaces, to a minimum of a 6mm bead. Apertures for penetrating services are to be tightly fitted and sealed. Imperfections should be filled with FS702 Intumastic to the full depth of the FB750 Intubatt. Service openings should be cut no more than 15mm away from non-combustible services, and/or, openings should be cut to suit the requirements of any additional required Nullifire product, if the service type is combustible or insulated CS or LS. External sides of the Board may be required to be coated for aesthetic reasons or to prevent fibre migration. (In situations where the required overlap cannot be achieved due to a perpendicular fire resisting wall / soffit, it is possible to reduce the overlap, down to as low as 0mm, provided the board edge is bonded to the adjoining compartment using a 10mm bead of FS702 Intumastic, and subsequently pointed to all mated edges)
The results below are also applicable when using multiple layers of surface mounted FB750 Intubatt. For multiple layers of FB750 Intubatt so a single (or both) face, identically sized boards should be used, ideally with staggered joints where possible. Closing devices should be located in or on the outmost board. Board to board abutment should be bonded with 10mm bead of FS702 Intumastic and mechanically restrained using a 75mm spiral screw to the first and secured layer. Spiral fixings should be at max 200mm centres and no more than 50mm from any joint.

Form-ULID-006104 (DCS:27-CP-F0855) 5.0



Appendix UL-EU CERTIFICATE

Certificate No. UL-EU-01058-CPR

Page 54/144

Date of Issue 2017-10-27

Service	CS Pipe Insulation (Continuous Sustained)		Pipe Diameter (mm)	Pipe Wall Thickness (mm)	Pipe End Configuration		Integrity E (mins)	Integrity & Insulation EI (mins)	Rigid Wall Thickness (mm) ≥ 100	Flexible Wall Thickness (mm) ≥ 100	Additional Requirements (Both Sides)
	Material	Thickness (mm)			C/C	U/C					
PE pipe (+ ABS, San+ PVC, PVC-U & PVC-C)	Nitrile (Elastomeric)	19	≤ 40	≥ 2.4	✓	✓	90	90	✓	✓	2 layers of FP302 Intustrap, sealed within FB750 Intubatt with FS702 Intumastic
PE pipe (+ ABS, San+ PVC, PVC-U & PVC-C)	Nitrile (Elastomeric)	19	≤ 40	≥ 3.7	✓	✓	90	90	✓	✓	2 layers of FP302 Intustrap, sealed within FB750 Intubatt with FS702 Intumastic
PP pipe	Nitrile (Elastomeric)	19	≤ 40	≥ 1.8	✓	✓	90	90	✓	✓	2 layers of FP302 Intustrap, sealed within FB750 Intubatt with FS702 Intumastic
PP pipe	Nitrile (Elastomeric)	19	≤ 40	≥ 5.5	✓	✓	90	90	✓	✓	2 layers of FP302 Intustrap, sealed within FB750 Intubatt with FS702 Intumastic
PVC-U pipe (+ PVC-C)	Nitrile (Elastomeric)	19	≤ 40	≥ 3	✓	✓	90	90	✓	✓	2 layers of FP302 Intustrap, sealed within FB750 Intubatt with FS702 Intumastic
PVC-U pipe (+ PVC-C)	Nitrile (Elastomeric)	19	≤ 40	≥ 1.9	✓	✓	90	90	✓	✓	2 layers of FP302 Intustrap, sealed within FB750 Intubatt with FS702 Intumastic
PVC-U pipe (+ PVC-C)	Glass Fibre	≥ 50	≤ 20	≥ 1.5	✓	✓	120	30	✓		2 layers of FP302 Intustrap, sealed within FB750 Intubatt with FS702 Intumastic

Form-ULID-006104 (DCS:27-CP-F0855) 5.0



Appendix UL-EU CERTIFICATE

Certificate No. UL-EU-01058-CPR
Page 56/144
Date of Issue 2017-10-27

Combustible Pipes Insulated CS – Double Batt Compression

Combustible Pipes Insulated with Continuous Sustained insulation passing through Flexible and Rigid Walls as identified below, protected by double compressed FB750 Intubatt seal, sealed with FS702 Intumastic or FS712 Intucoat.
Wall Details: Flexible or Rigid Walls including Concrete, Brick / Blockwork & AAC, of minimum thickness as identified below, and with performance classified to EN 13501-2. Flexible Walls constructed from steel or timber faced studs with a minimum of 2x12.5mm EN 520 type F boards on each side of studs.
Maximum Opening size: 900mm by 550mm. In Flexible Walls openings should be created using a steel frame. Multiple openings must be separated by a minimum of 200mm for fire resistance requirements. Check separation requirements with the system owner of the supporting construction.
The Installation Instructions: Double Layer board, compressed and bonded into the aperture outer face flush with the face of the supporting construction. FB750 Intubatt should be installed in as few cut pieces as possible and tightly compressed to two opposite sides. This is achieved by the addition of 2mm to the required cut dimension. Compression may be applied - FB750 Intubatt to FB750 Intubatt, FB750 Intubatt to non-combustible service, or FB750 Intubatt to Substrate. Compression must be achieved over a minimum 60% of the FB750 Intubatt compressed edge. If compression is achieved Top to bottom of FB750 Intubatt, left/right is not required to be compressed and vice versa (the non-compressed seal should be fully abutted and bonded). All joints are to be bonded using FS712 Intucoat to full width of the FB750 Intubatt or FS702 Intumastic applied as a 10mm bead along the full-length joint centre line. FS702 Intumastic should be used to point all service and substrate interfaces, to a minimum of a 6mm bead. Apertures for penetrating services are to be tightly fitted and sealed. Imperfections should be filled with FS702 Intumastic to the full depth of the FB750 Intubatt. Service openings should be cut no more than 15mm away from non-combustible services, and/or, openings should be cut to suit the requirements of any additional required Nullifire product, if the service type is combustible or insulated CS or LS. (Imperfections in cut on a compressed edge may not exceed 40% of the area available to receive compression)
The results below are also applicable when using multiple layers of FB750 Intubatt, including 1 layer (or more) surface mounted on both sides of the wall.

Form-ULID-006104 (DCS:27-CP-F0855) 5.0



Appendix UL-EU CERTIFICATE

Certificate No. UL-EU-01058-CPR
 Page 57/144
 Date of Issue 2017-10-27

Service	CS Pipe Insulation (Continuous Sustained)		Pipe Diameter (mm)	Pipe Wall Thickness (mm)	Pipe End Configuration		Integrity E (mins)	Integrity & Insulation EI (mins)	Rigid Wall Thickness (mm) ≥ 100	Flexible Wall Thickness (mm) ≥ 100	Additional Requirements
	Material	Thickness (mm)			C/C	U/C					
PVC-U pipe (+ PVC-C)	Nitrile (Elastomeric)	19	≤ 40	≥ 3	✓	✓	90	90	✓	✓	2 layers of FP302 Intustrap (central to the seal), sealed on both sides of FB750 Intubatt with FS702 Intumastic
PVC-U pipe (+ PVC-C)	Nitrile (Elastomeric)	19	≤ 40	≥ 1.9	✓	✓	90	90	✓	✓	2 layers of FP302 Intustrap (central to the seal), sealed on both sides of FB750 Intubatt with FS702 Intumastic
PVC-U pipe (+ PVC-C)	Glass Fibre	≥ 50	≤ 20	≥ 1.5	✓	✓	120	30	✓		2 layers of FP302 Intustrap (central to the seal), sealed on both sides of FB750 Intubatt with FS702 Intumastic
PP pipe	Nitrile (Elastomeric)	19	≤ 40	≥ 1.8	✓	✓	90	60	✓	✓	2 layers of FP302 Intustrap (central to the seal), sealed on both sides of FB750 Intubatt with FS702 Intumastic
PP pipe	Nitrile (Elastomeric)	19	≤ 40	≥ 5.5	✓	✓	60	60	✓	✓	2 layers of FP302 Intustrap (central to the seal), sealed on both sides of FB750 Intubatt with FS702 Intumastic
PE pipe (+ ABS, San+ PVC, PVC-U & PVC-C)	Nitrile (Elastomeric)	19	≤ 40	≥ 3.7	✓	✓	60	60	✓	✓	2 layers of FP302 Intustrap (central to the seal), sealed on both sides of FB750 Intubatt with FS702 Intumastic
PE pipe (+ ABS, San+ PVC, PVC-U & PVC-C)	Nitrile (Elastomeric)	19	≤ 40	≥ 2.4	✓	✓	60	60	✓	✓	2 layers of FP302 Intustrap (central to the seal), sealed on both sides of FB750 Intubatt with FS702 Intumastic



Appendix UL-EU CERTIFICATE

Certificate No. UL-EU-01058-CPR
 Page 58/144
 Date of Issue 2017-10-27

Combustible Pipes Insulated CS – Single Batt Compression

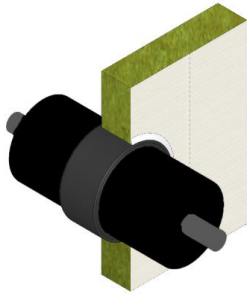
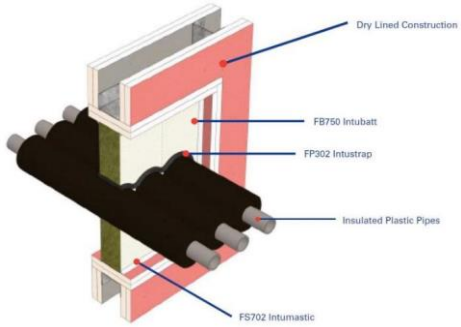
Combustible Pipes Insulated with Continuous Sustained insulation passing through Flexible and Rigid Walls as identified below, protected by single compressed FB750 Intubatt seal, sealed with FS702 Intumastic or FS712 Intucoat.	
Wall Details: Flexible or Rigid Walls including Concrete, Brick / Blockwork & AAC, of minimum thickness as identified below, and with performance classified to EN 13501-2. Flexible Walls constructed from steel or timber faced studs with a minimum of 2x12.5mm EN 520 type F boards on each side of studs.	
Maximum Opening size: 900mm by 550mm. In Flexible Walls openings should be created using a steel frame with a plasterboard lining. Multiple openings must be separated by a minimum of 200mm for fire resistance requirements. Check separation requirements with the system owner of the supporting construction.	
Installation Instructions: Single Layer board, compressed and bonded into the aperture at mid depth of the wall. FB750 Intubatt should be installed in as few cut pieces as possible and tightly compressed to two opposite sides. This is achieved by the addition of 2mm to the required cut dimension. Compression may be applied - FB750 Intubatt to FB750 Intubatt, FB750 Intubatt to non-combustible service, or FB750 Intubatt to Substrate. Compression must be achieved over a minimum 60% of the FB750 Intubatt Compressed edge. If compression is achieved Top to bottom of FB750 Intubatt, left/right is not required to be compressed and vice versa (the non-compressed seal should be fully abutted and bonded). All joints are to be bonded using FS712 Intucoat to full width of the FB750 Intubatt or FS702 Intumastic applied as a 10mm bead along the full-length joint centre line. FS702 Intumastic should be used to point all service and substrate interfaces, to a minimum of a 6mm bead. Apertures for penetrating services are to be tightly fitted and sealed. Imperfections should be filled with FS702 Intumastic to the full depth of the FB750 Intubatt. Service openings should be cut no more than 15mm away from non-combustible services, and/or, openings should be cut to suit the requirements of any additional required Nullfire product, if the service type is combustible or insulated CS or LS. (Imperfections in cut on a compressed edge may not exceed 40% of the area available to receive compression)	
The results below are also applicable when using multiple layers of FB750 Intubatt, including 1 layer (or more) surface mounted on both sides of the wall.	
	

Form-ULID-006104 (DCS:27-CP-F0855) 5.0



Appendix UL-EU CERTIFICATE

Certificate No. UL-EU-01058-CPR
 Page 59/144
 Date of Issue 2017-10-27

Service	CS Pipe Insulation (Continuous Sustained)		Pipe Diameter (mm)	Pipe Wall Thickness (mm)	Pipe End Configuration		Integrity E (mins)	Integrity & Insulation EI (mins)	Rigid Wall Thickness (mm) ≥ 100	Flexible Wall Thickness (mm) ≥ 100	Additional Requirements
	Material	Thickness (mm)			C/C	U/C					
PP pipe	Nitrile (Elastomeric)	19	≤ 40	≥ 1.8	✓	✓	90	60	✓	✓	2 layers of FP302 Intustrap (central to the seal), sealed on both sides of FB750 Intubatt with FS702 Intumastic
PE pipe (+ HDPE, ABS, San+ PVC, PVC-U & PVC-C)	Nitrile (Elastomeric)	19	≤ 40	≥ 2.4	✓	✓	90	30	✓	✓	2 layers of FP302 Intustrap (central to the seal), sealed on both sides of FB750 Intubatt with FS702 Intumastic
PVC-U pipe (+ PVC-C)	Glass Fibre	≥ 50	≤ 20	≥ 1.5	✓	✓	90	30	✓		2 layers of FP302 Intustrap (central to the seal), sealed on both sides of FB750 Intubatt with FS702 Intumastic
PVC-U pipe (+ PVC-C)	Nitrile (Elastomeric)	19	≤ 40	≥ 3	✓	✓	60	30	✓	✓	2 layers of FP302 Intustrap (central to the seal), sealed on both sides of FB750 Intubatt with FS702 Intumastic
PVC-U pipe (+ PVC-C)	Nitrile (Elastomeric)	19	≤ 40	≥ 1.9	✓	✓	60	30	✓	✓	2 layers of FP302 Intustrap (central to the seal), sealed on both sides of FB750 Intubatt with FS702 Intumastic



Appendix UL-EU CERTIFICATE

Certificate No. UL-EU-01058-CPR
 Page 60/144
 Date of Issue 2017-10-27

Non-Combustible Pipes – Double Batt Pattress

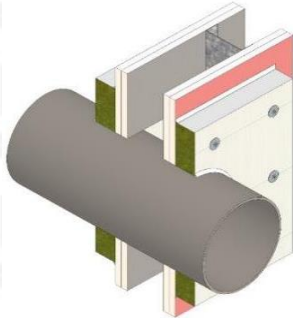
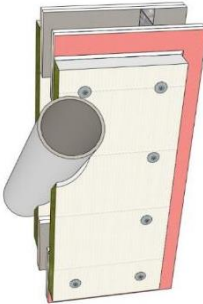
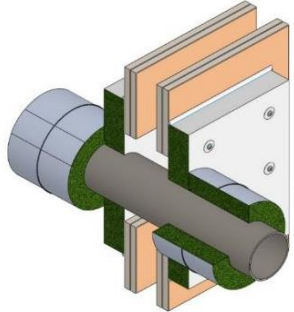
<p>Non-Combustible Pipes through Flexible and Rigid Walls as identified below, protected by double pattress (surface mounted) FB750 Intubatt seal, sealed with FS702 Intumastic or FS712 Intucoat.</p>		
<p>Wall Details: Flexible or Rigid Walls including Concrete, Brick / Blockwork & AAC, of minimum thickness as identified below, and with performance classified to EN 13501-2. Flexible Walls constructed from steel or timber faced studs with a minimum of 2x12.5mm EN 520 type F boards on each side of studs.</p>		
<p>Maximum Opening size: 1200mm by 500mm. Multiple openings must be separated by a minimum of 200mm for fire resistance requirements. Check separation requirements with the system owner of the supporting construction.</p>		
<p>Installation Instructions: Boards surface mounted (pattress fit) on both sides of the wall with a minimum 75mm overlap around the opening. (Overlap on the lowest edge can be reduced to 30mm in the event of an obstruction preventing the 75mm overlap). The overlap should be bonded with a 10mm bead of FS702 Intumastic placed 20-60mm from the board edges, and additionally mechanically restrained using 75mm steel screws with a 25mm washer at maximum 300mm centres, 10-65mm from the board perimeter and no more than 50mm from a board joint. A low torque setting should be used to ensure that the embedment of fixing into the board does not exceed 15mm. The fixings may be left exposed or covered using FS702 Intumastic. The FB750 Intubatt should be installed in as few cut pieces as possible. All joints are to be bonded using FS712 Intucoat to full width of the FB750 Intubatt or FS702 Intumastic applied as a 10mm bead along the full-length joint centre line. FS702 Intumastic should be used to point all service and substrate interfaces, to a minimum of a 6mm bead. Apertures for penetrating services are to be tightly fitted and sealed. Imperfections should be filled with FS702 Intumastic to the full depth of the FB750 Intubatt. Service openings should be cut no more than 15mm away from non-combustible services, and/or, openings should be cut to suit the requirements of any additional required Nullifire product, if the service type is combustible or insulated CS or LS. External sides of the Board may be required to be coated for aesthetic reasons or to prevent fibre migration. (In situations where the required overlap cannot be achieved due to a perpendicular fire resisting wall / soffit, it is possible to reduce the overlap, down to as low as 0mm, provided the board edge is bonded to the adjoining compartment using a 10mm bead of FS702 Intumastic, and subsequently pointed to all mated edges)</p>		
<p>The results below are also applicable when using multiple layers of surface mounted FB750 Intubatt. For multiple layers of FB750 Intubatt so a single (or both) face, identically sized boards should be used, ideally with staggered joints where possible. Closing devices should be located in or on the outmost board. Board to board abutment should be bonded with 10mm bead of FS702 Intumastic and mechanically restrained using a 75mm spiral screw to the first and secured layer. Spiral fixings should be at max 200mm centres and no more than 50mm from any joint.</p>		
		

Form-ULID-006104 (DCS:27-CP-F0855) 5.0



Appendix UL-EU CERTIFICATE

Certificate No. UL-EU-01058-CPR
 Page 61/144
 Date of Issue 2017-10-27

Service				Pipe Diameter	Pipe Wall Thickness#	Pipe End Configuration		Integrity	Integrity & Insulation	Rigid Wall Thickness (mm)				Flexible Wall Thickness (mm)			Additional Requirements (Both Sides)
Cast Iron	Steel	Copper	-	(mm)	(mm)	C/C	C/U	E (mins)	EI (mins)	≥ 150	≥ 130	≥ 100	≥ 90	≥ 130	≥ 100	≥ 90	
✓	✓	✓		≤ 42	≥ 1	✓	✓	240	120	✓							200mm extension of 1 layer of FI025 Intuflex, sealed to FB750 Intubatt with FS702 Intumastic
✓	✓	✓	(*)	≤ 14	≥ 1.2	✓	✓	120	120	✓	✓	✓	✓	✓	✓	✓	200mm extension of 1 layer of FI025 Intuflex, sealed to FB750 Intubatt with FS702 Intumastic
✓	✓	✓	(*)	≤ 28	≥ 1.2	✓	✓	120	120	✓	✓	✓	✓	✓	✓	✓	200mm extension of 1 layer of FI025 Intuflex, sealed to FB750 Intubatt with FS702 Intumastic
✓	✓	✓		≤ 14	≥ 1	✓	✓	120	120	✓	✓	✓		✓	✓		200mm extension of 1 layer of FI025 Intuflex, sealed to FB750 Intubatt with FS702 Intumastic
✓	✓	✓		≤ 28	≥ 1	✓	✓	120	120	✓	✓	✓		✓	✓		200mm extension of 1 layer of FI025 Intuflex, sealed to FB750 Intubatt with FS702 Intumastic
✓	✓	✓		≤ 42	≥ 1	✓	✓	120	120	✓	✓	✓		✓	✓		200mm extension of 1 layer of FI025 Intuflex, sealed to FB750 Intubatt with FS702 Intumastic
✓	✓	✓		≤ 160	≥ 2	✓	✓	120	120	✓	✓			✓			500mm extension of 2 layers of FI025 Intuflex, sealed to FB750 Intubatt with FS702 Intumastic
✓	✓	✓	(*)	≤ 42	≥ 1.2	✓	✓	120	90	✓	✓	✓	✓	✓	✓	✓	200mm extension of 1 layer of FI025 Intuflex, sealed to FB750 Intubatt with FS702 Intumastic
✓	✓	✓		≤ 15	≥ 0.8	✓	✓	120	90	✓	✓			✓			-
✓	✓	✓		≤ 35	≥ 1.2	✓	✓	120	60	✓	✓	✓		✓	✓		-
✓	✓	✓		≤ 15	≥ 0.7	✓	✓	90	90	✓	✓	✓		✓	✓		-



Appendix UL-EU CERTIFICATE

Certificate No. UL-EU-01058-CPR
 Page 62/144
 Date of Issue 2017-10-27

Service				Pipe Diameter	Pipe Wall Thickness#	Pipe End Configuration		Integrity	Integrity & Insulation	Rigid Wall Thickness (mm)				Flexible Wall Thickness (mm)			Additional Requirements (Both Sides)
Cast Iron	Steel	Copper	-	(mm)	(mm)	C/C	C/U	E (mins)	EI (mins)	≥ 150	≥ 130	≥ 100	≥ 90	≥ 130	≥ 100	≥ 90	
✓	✓	✓	(*)	≤ 28	≥ 1	✓	✓	60	60	✓	✓	✓		✓	✓		200mm extension of 1 layer of FI025 Intuflex, sealed to FB750 Intubatt with FS702 Intumastic
✓	✓	✓		≤ 160	≥ 1.2	✓	✓	120	30	✓	✓	✓	✓	✓	✓	✓	500mm extension of 2 layers of FI025 Intuflex, sealed to FB750 Intubatt with FS702 Intumastic
✓	✓	✓		≤ 14	≥ 1.2	✓	✓	120	30	✓	✓	✓	✓	✓	✓	✓	-
✓	✓	✓	(*)	≤ 14	≥ 1.2	✓	✓	120	30	✓	✓			✓			-

#Up to maximum 14.2 mm

Service				Pipe Diameter	Pipe Wall Thickness#	Pipe End Configuration		Integrity	Integrity & Insulation	Rigid Wall Thickness (mm)				Flexible Wall Thickness (mm)			Additional Requirements (Both Sides)
Cast Iron	Steel	Copper	-	(mm)	(mm)	C/C	C/U	E (mins)	EI (mins)	≥ 150	≥ 130	≥ 100	≥ 90	≥ 130	≥ 100	≥ 90	
✓	✓	✓		≤ 22	≥ 1	✓	✓	120	30	✓	✓	✓		✓	✓		200mm coatback of FS712 Intucoat 2mm WFT
✓	✓	✓		≤ 28	≥ 1	✓	✓	60	30	✓	✓	✓		✓	✓		-
✓	✓	✓	(*)	≤ 42	≥ 1	✓	✓	60	30	✓	✓	✓		✓	✓		200mm extension of 1 layer of FI025 Intuflex, sealed to FB750 Intubatt with FS702 Intumastic
✓	✓	✓		≤ 28	≥ 1.2	✓	✓	30	30	✓	✓	✓	✓	✓	✓	✓	-
✓	✓	✓	(*)	≤ 42	≥ 1.2	✓	✓	120	15	✓	✓	✓		✓	✓		-



Appendix UL-EU CERTIFICATE

Certificate No. UL-EU-01058-CPR
 Page 63/144
 Date of Issue 2017-10-27

Service				Pipe Diameter	Pipe Wall Thickness#	Pipe End Configuration		Integrity	Integrity & Insulation	Rigid Wall Thickness (mm)				Flexible Wall Thickness (mm)			Additional Requirements (Both Sides)
Cast Iron	Steel	Copper	-	(mm)	(mm)	C/C	C/U	E (mins)	EI (mins)	≥ 150	≥ 130	≥ 100	≥ 90	≥ 130	≥ 100	≥ 90	
✓	✓			≤ 76	≥ 2	✓	✓	240	120	✓							200mm extension of 1 layer of FI025 Intuflex, sealed to FB750 Intubatt with FS702 Intumastic
✓	✓			≤ 20	≥ 1.5	✓	✓	120	120	✓	✓						-
✓	✓			≤ 60	≥ 3.3	✓	✓	120	90	✓	✓						-
✓	✓			≤ 220	≥ 8.5	✓	✓	120	60	✓	✓			✓			-
✓	✓			≤ 10	≥ 1.8	✓	✓	90	60	✓	✓	✓		✓	✓		200mm coatback of FS712 Intucoat 2mm WFT
✓	✓			≤ 87	≥ 4	✓	✓	60	45	✓	✓						-
✓	✓			≤ 220	≥ 6	✓	✓	120	30	✓	✓	✓		✓	✓		200mm coatback of FS712 Intucoat 2mm WFT
✓	✓			≤ 64	≥ 3	✓	✓	120	30	✓	✓	✓		✓	✓		200mm coatback of FS712 Intucoat 2mm WFT
✓	✓			≤ 76	≥ 3.4	✓	✓	240	15	✓							-
✓	✓			≤ 90	≥ 3	✓	✓	120	15	✓	✓	✓		✓	✓		200mm coatback of FS712 Intucoat 2mm WFT

(*) Includes horizontal pipes from 90° to 45° to supporting construction
 #Up to maximum 14.2 mm



Appendix UL-EU CERTIFICATE

Certificate No. UL-EU-01058-CPR
Page 64/144
Date of Issue 2017-10-27

Non-Combustible Pipes – Double Batt Pattress (Asymmetric)

Non-Combustible Pipes through Rigid Walls as identified below, protected by double battress (surface mounted) asymmetric FB750 Intubatt seal, sealed with FS702 Intumastic or FS712 Intucoat.

Wall Details: Rigid Walls including Concrete, Brick / Blockwork & AAC, of minimum thickness as identified below and with performance classified to EN13501-2.

Maximum Opening size: 1100mm by 450mm. Multiple openings must be separated by a minimum of 200mm for fire resistance requirements. Check separation requirements with the system owner of the supporting construction.

Installation Instructions: Double layer board surface mounted (pattress fit) together on the opposite side of the wall to the fire, with a minimum 75mm overlap around the opening. (Overlap on the lowest edge can be reduced to 30mm in the event of an obstruction preventing the 75mm overlap). The overlap should be bonded with a 10mm bead of FS702 Intumastic placed 20-60mm from the board edges, and additionally mechanically restrained using 75mm steel screws with a 25mm washer at maximum 300mm centres, 10-65mm from the board perimeter and no more than 50mm from a board joint. A low torque setting should be used to ensure that the embedment of fixing into the board does not exceed 15mm. The fixings may be left exposed or covered using FS702 Intumastic. The FB750 Intubatt should be installed in as few cut pieces as possible. All joints are to be bonded using FS712 Intucoat to full width of the FB750 Intubatt or FS702 Intumastic applied as a 10mm bead along the full-length joint centre line. FS702 Intumastic should be used to point all service and substrate interfaces, to a minimum of a 6mm bead. Apertures for penetrating services are to be tightly fitted and sealed. Imperfections should be filled with FS702 Intumastic to the full depth of the FB750 Intubatt. Service openings should be cut no more than 15mm away from non-combustible services, and/or, openings should be cut to suit the requirements of any additional required Nullifire product, if the service type is combustible or insulated CS or LS. External sides of the Board may be required to be coated for aesthetic reasons or to prevent fibre migration. (In situations where the required overlap cannot be achieved due to a perpendicular fire resisting wall / soffit, it is possible to reduce the overlap, down to as low as 0mm, provided the board edge is bonded to the adjoining compartment using a 10mm bead of FS702 Intumastic, and subsequently pointed to all mated edges)

The results below are also applicable when using multiple layers of surface mounted FB750 Intubatt. Results could also be used in both directions with double layer surface mounted of FB750 Intubatt on both sides of the opening.

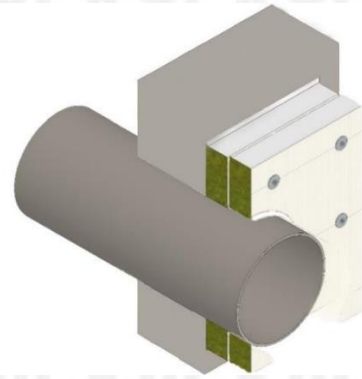

Form-ULID-006104 (DCS:27-CP-F0855) 5.0



Appendix UL-EU CERTIFICATE

Certificate No. UL-EU-01058-CPR
 Page 65/144
 Date of Issue 2017-10-27

Service			Pipe Diameter	Pipe Wall Thickness#	Pipe End Configuration		Integrity	Integrity & Insulation	Rigid Wall Thickness (mm)	Additional Requirements (Both Sides)
Cast Iron	Steel	Copper	(mm)	(mm)	C/C	C/U	E (mins)	EI (mins)	≥ 150	
✓	✓		≤ 40	≥ 2	✓	✓	240	120	✓	200mm extension of 1 layer of FI025 Intuflex, sealed to FB750 Intubatt with FS702 Intumastic
✓	✓		≤ 40	≥ 1.7	✓	✓	240	120	✓	-
✓	✓		≤ 110	≥ 2.2	✓	✓	240	30	✓	200mm extension of 1 layer of FI025 Intuflex, sealed to FB750 Intubatt with FS702 Intumastic
✓	✓	✓	≤ 40	≥ 1.5	✓	✓	240	60	✓	200mm extension of 1 layer of FI025 Intuflex, sealed to FB750 Intubatt with FS702 Intumastic
✓	✓	✓	≤ 110	≥ 2.7	✓	✓	240	15	✓	200mm extension of 1 layer of FI025 Intuflex, sealed to FB750 Intubatt with FS702 Intumastic

#Up to maximum 14.2 mm



Appendix UL-EU CERTIFICATE

Certificate No. UL-EU-01058-CPR
 Page 66/144
 Date of Issue 2017-10-27

Non-Combustible Pipes – Double Batt Compression

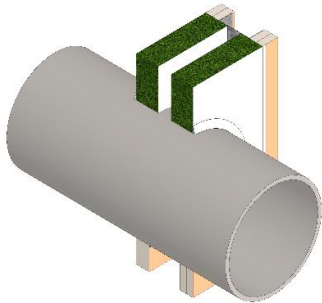
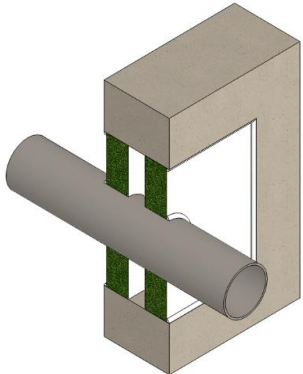
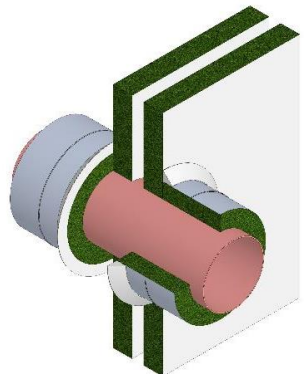
Uninsulated Non-Combustible Pipes through Flexible and Rigid Walls as identified below, protected by double compressed FB750 Intubatt seal, sealed with FS702 Intumastic or FS712 Intucoat.		
Wall Details: Flexible or Rigid Walls including Concrete, Brick / Blockwork & AAC, of minimum thickness as identified below, and with performance classified to EN 13501-2. Flexible Walls constructed from steel or timber faced studs with a minimum of 2 x 12.5mm EN 520 type F boards on each side of studs.		
Maximum Opening size: 2000mm by \leq 1100mm. In Flexible Walls openings should be created using a steel frame. Multiple openings must be separated by a minimum of 200mm for fire resistance requirements. Check separation requirements with the system owner of the supporting construction.		
Installation Instructions: Double Layer board, compressed and bonded into the aperture outer face flush with the face of the supporting construction. FB750 Intubatt should be installed in as few cut pieces as possible and tightly compressed to two opposite sides. This is achieved by the addition of 2mm to the required cut dimension. Compression may be applied - FB750 Intubatt to FB750 Intubatt, FB750 Intubatt to non-combustible service, or FB750 Intubatt to Substrate. Compression must be achieved over a minimum 60% of the FB750 Intubatt compressed edge. If compression is achieved Top to bottom of FB750 Intubatt, left/right is not required to be compressed and vice versa (the non-compressed seal should be fully abutted and bonded). All joints are to be bonded using FS712 Intucoat to full width of the FB750 Intubatt or FS702 Intumastic applied as a 10mm bead along the full-length joint centre line. FS702 Intumastic should be used to point all service and substrate interfaces, to a minimum of a 6mm bead. Apertures for penetrating services are to be tightly fitted and sealed. Imperfections should be filled with FS702 Intumastic to the full depth of the FB750 Intubatt. Service openings should be cut no more than 15mm away from non-combustible services, and/or, openings should be cut to suit the requirements of any additional required Nullifire product, if the service type is combustible or insulated CS or LS. (Imperfections in cut on a compressed edge may not exceed 40% of the area available to receive compression)		
The results below are also applicable when using multiple layers of FB750 Intubatt, including 1 layer (or more) surface mounted on both sides of the wall.		
		

Form-ULID-006104 (DCS:27-CP-F0855) 5.0



Appendix UL-EU CERTIFICATE

Certificate No. UL-EU-01058-CPR
 Page 67/144
 Date of Issue 2017-10-27

Service				Pipe Diameter	Pipe Wall Thickness#	Pipe End Configuration		Integrity	Integrity & Insulation	Rigid Wall Thickness (mm)			Flexible Wall Thickness (mm)		Additional Requirements (Both Sides)
Cast Iron	Steel	Copper	-	(mm)	(mm)	C/C	C/U	E (mins)	EI (mins)	≥ 150	≥ 130	≥ 100	≥ 130	≥ 100	
✓	✓	✓		≤ 42	≥ 1	✓	✓	240	120	✓					200mm extension of 1 layer of FI025 Intuflex, sealed to FB750 Intubatt with FS702 Intumastic
✓	✓	✓		≤ 42	≥ 1	✓	✓	120	120	✓	✓	✓	✓	✓	200mm extension of 1 layer of FI025 Intuflex, sealed to FB750 Intubatt with FS702 Intumastic
✓	✓	✓		≤ 160	≥ 2	✓	✓	120	120	✓	✓		✓		500mm extension of 2 layers of FI025 Intuflex, sealed to FB750 Intubatt with FS702 Intumastic
✓	✓	✓		≤ 15	≥ 0.8	✓	✓	120	90	✓	✓		✓		-
✓	✓	✓	(*)	≤ 28	≥ 1	✓	✓	60	60	✓	✓	✓	✓	✓	200mm extension of 1 layer of FI025 Intuflex, sealed to FB750 Intubatt with FS702 Intumastic
✓	✓	✓	(*)	≤ 14	≥ 1.2	✓	✓	120	30	✓	✓	✓	✓	✓	-
✓	✓	✓	(*)	≤ 42	≥ 1.2	✓	✓	120	15	✓	✓	✓	✓	✓	-
✓	✓	✓		≤ 22	≥ 1	✓	✓	120	15	✓	✓	✓	✓	✓	200mm coatback of FS712 Intucoat 2mm WFT
✓	✓			≤ 76	≥ 2	✓	✓	240	120	✓					200mm extension of 1 layer of FI025 Intuflex, sealed to FB750 Intubatt with FS702 Intumastic
✓	✓			≤ 220	≥ 8.5	✓	✓	120	60	✓	✓		✓		-
✓	✓			≤ 22	≥ 1	✓	✓	120	30	✓	✓	✓	✓	✓	200mm coatback of FS712 Intucoat 2mm WFT
✓	✓			≤ 220	≥ 6	✓	✓	120	30	✓	✓	✓	✓	✓	200mm coatback of FS712 Intucoat 2mm WFT



Appendix UL-EU CERTIFICATE

Certificate No. UL-EU-01058-CPR
 Page 68/144
 Date of Issue 2017-10-27

Service				Pipe Diameter	Pipe Wall Thickness#	Pipe End Configuration		Integrity	Integrity & Insulation	Rigid Wall Thickness (mm)			Flexible Wall Thickness (mm)		Additional Requirements (Both Sides)
Cast Iron	Steel	Copper	-	(mm)	(mm)	C/C	C/U	E (mins)	EI (mins)	≥ 150	≥ 130	≥ 100	≥ 130	≥ 100	
✓	✓			≤ 64	≥ 3	✓	✓	120	30	✓	✓	✓	✓	✓	200mm coatback of FS712 Intucoat 2mm WFT
✓	✓			≤ 65	≥ 3.2	✓	✓	90	30	✓	✓	✓	✓	✓	200mm coatback of FS712 Intucoat 2mm WFT
✓	✓			≤ 76	≥ 3.4	✓	✓	240	15	✓					-
✓	✓			≤ 90	≥ 3	✓	✓	120	15	✓	✓	✓	✓	✓	200mm coatback of FS712 Intucoat 2mm WFT

(*) Includes horizontal pipes from 90° to 45° to supporting construction
 #Up to maximum 14.2 mm



Appendix UL-EU CERTIFICATE

Certificate No. UL-EU-01058-CPR
Page 69/144
Date of Issue 2017-10-27

Non-Combustible Pipes – Double Batt Compression (Asymmetric)

Uninsulated Non-Combustible Pipes through Rigid Walls as identified below, protected by double compressed asymmetric FB750 Intubatt seal, sealed with FS702 Intumastic or FS712 Intucoat.

Wall Details: Rigid Walls including Concrete, Brick / Blockwork & AAC, of minimum thickness as identified below, and with performance classified to EN 13501-2.

Maximum Opening size: $\leq 1100\text{mm}$ by 450mm . Multiple openings must be separated by a minimum of 200mm for fire resistance requirements. Check separation requirements with the system owner of the supporting construction.

Installation Instructions: Double Layer board, compressed and bonded together into the aperture outer face flush with the face of the supporting construction on the opposite side to the fire. FB750 Intubatt should be installed in as few cut pieces as possible and tightly compressed to two opposite sides. This is achieved by the addition of 2mm to the required cut dimension. Compression may be applied - FB750 Intubatt to FB750 Intubatt, FB750 Intubatt to non-combustible service, or FB750 Intubatt to Substrate. Compression must be achieved over a minimum 60% of the FB750 Intubatt compressed edge. If compression is achieved Top to bottom of FB750 Intubatt, left/right is not required to be compressed and vice versa (the non-compressed seal should be fully abutted and bonded). All joints are to be bonded using FS712 Intucoat to full width of the FB750 Intubatt or FS702 Intumastic applied as a 10mm bead along the full-length joint centre line. FS702 Intumastic should be used to point all service and substrate interfaces, to a minimum of a 6mm bead. Apertures for penetrating services are to be tightly fitted and sealed. Imperfections should be filled with FS702 Intumastic to the full depth of the FB750 Intubatt. Service openings should be cut no more than 15mm away from non-combustible services, and/or, openings should be cut to suit the requirements of any additional required Nullifire product, if the service type is combustible or insulated CS or LS. (Imperfections in cut on a compressed edge may not exceed 40% of the area available to receive compression)

The results below are also applicable when using multiple layers of FB750 Intubatt, including 2 layers (or more) of surface mounted FB750 Intubatt. Results could also be used in both directions with the addition of FB750 Intubatt to fully fill the opening.

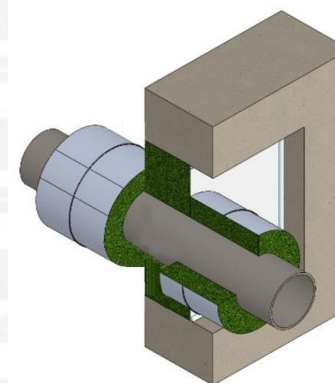
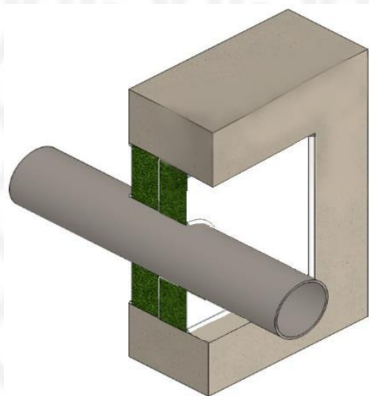

Form-ULID-006104 (DCS:27-CP-F0855) 5.0



Appendix UL-EU CERTIFICATE

Certificate No. UL-EU-01058-CPR
 Page 70/144
 Date of Issue 2017-10-27

Service			Pipe Diameter	Pipe Wall Thickness#	Pipe End Configuration		Integrity	Integrity & Insulation	Rigid Wall Thickness (mm)	Additional Requirements (Both Sides)
Cast Iron	Steel	Copper	(mm)	(mm)	C/C	C/U	E (mins)	EI (mins)	≥ 150	
✓	✓		≤ 40	≥ 2	✓	✓	240	120	✓	200mm extension of 1 layer of FI025 Intuflex, sealed to FB750 Intubatt with FS702 Intumastic
✓	✓		≤ 40	≥ 1.7	✓	✓	240	120	✓	-
✓	✓		≤ 110	≥ 2.2	✓	✓	240	30	✓	200mm extension of 1 layer of FI025 Intuflex, sealed to FB750 Intubatt with FS702 Intumastic
✓	✓	✓	≤ 40	≥ 1.5	✓	✓	240	60	✓	200mm extension of 1 layer of FI025 Intuflex, sealed to FB750 Intubatt with FS702 Intumastic

#Up to maximum 14.2 mm



Appendix UL-EU CERTIFICATE

Certificate No. UL-EU-01058-CPR
Page 71/144
Date of Issue 2017-10-27

Non-Combustible Pipes – Single Batt Compression

Uninsulated Non-Combustible Pipes through Flexible and Rigid Walls as identified below, protected by single compressed FB750 Intubatt seal, sealed with FS702 Intumastic or FS712 Intucoat.
Wall Details: Flexible or Rigid Walls including Concrete, Brick / Blockwork & AAC, of minimum thickness as identified below, and with performance classified to EN 13501-2. Flexible Walls constructed from steel or timber faced studs with a minimum of 2 x 12.5mm EN 520 type F boards on each side of studs.
Maximum Opening size: 1800mm by 1200mm. In Flexible Walls openings should be created using a steel frame with a plasterboard lining. Multiple openings must be separated by a minimum of 200mm for fire resistance requirements. Check separation requirements with the system owner of the supporting construction.
Installation Instructions: Single Layer board, compressed and bonded into the aperture at mid depth of the wall. FB750 Intubatt should be installed in as few cut pieces as possible and tightly compressed to two opposite sides. This is achieved by the addition of 2mm to the required cut dimension. Compression may be applied - FB750 Intubatt to FB750 Intubatt, FB750 Intubatt to non-combustible service, or FB750 Intubatt to Substrate. Compression must be achieved over a minimum 60% of the FB750 Intubatt Compressed edge. If compression is achieved Top to bottom of FB750 Intubatt, left/right is not required to be compressed and vice versa (the non-compressed seal should be fully abutted and bonded). All joints are to be bonded using FS712 Intucoat to full width of the FB750 Intubatt or FS702 Intumastic applied as a 10mm bead along the full-length joint centre line. FS702 Intumastic should be used to point all service and substrate interfaces, to a minimum of a 6mm bead. Apertures for penetrating services are to be tightly fitted and sealed. Imperfections should be filled with FS702 Intumastic to the full depth of the FB750 Intubatt. Service openings should be cut no more than 15mm away from non-combustible services, and/or, openings should be cut to suit the requirements of any additional required Nullifire product, if the service type is combustible or insulated CS or LS. (Imperfections in cut on a compressed edge may not exceed 40% of the area available to receive compression)
The results below are also applicable when using multiple layers of FB750 Intubatt, including 1 layer (or more) surface mounted on both sides of the wall.

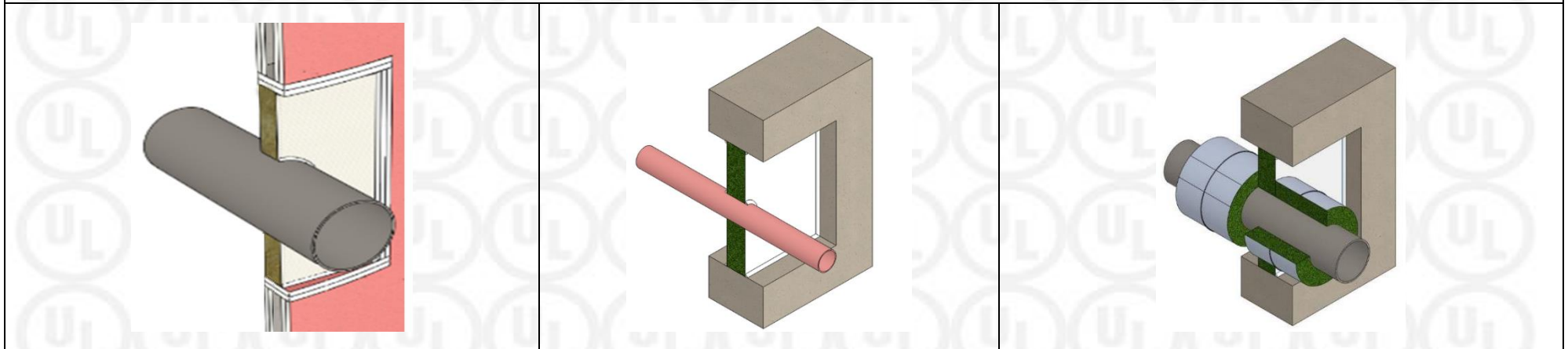

Form-ULID-006104 (DCS:27-CP-F0855) 5.0



Appendix UL-EU CERTIFICATE

Certificate No. UL-EU-01058-CPR
 Page 72/144
 Date of Issue 2017-10-27

Service			Pipe Diameter	Pipe Wall Thickness#	Pipe End Configuration		Integrity	Integrity & Insulation	Rigid Wall Thickness (mm)			Flexible Wall Thickness (mm)		Additional Requirements (Both Sides)
Cast Iron	Steel	Copper	(mm)	(mm)	C/C	C/U	E (mins)	EI (mins)	≥ 150	≥ 130	≥ 100	≥ 130	≥ 100	
✓	✓		≤ 160	≥ 5	✓	✓	120	60	✓					500mm extension (2 rows) of 2 layers of FI025 Intuflex, sealed to FB750 Intubatt with FS702 Intumastic
✓	✓		≤ 10	≥ 1.8	✓	✓	90	60	✓	✓	✓	✓	✓	200mm coatback of FS712 Intucoat 2mm WFT
✓	✓		≤ 22	≥ 1	✓	✓	120	30	✓	✓	✓	✓	✓	200mm coatback of FS712 Intucoat 2mm WFT
✓	✓		≤ 220	≥ 6	✓	✓	120	30	✓	✓	✓	✓	✓	200mm coatback of FS712 Intucoat 2mm WFT
✓	✓		≤ 64	≥ 3	✓	✓	120	30	✓	✓	✓	✓	✓	200mm coatback of FS712 Intucoat 2mm WFT
✓	✓		≤ 65	≥ 3.2	✓	✓	90	30	✓	✓	✓	✓	✓	200mm coatback of FS712 Intucoat 2mm WFT
✓	✓		≤ 76	≥ 3.4	✓	✓	240	15	✓					-
✓	✓		≤ 90	≥ 3	✓	✓	120	15	✓	✓	✓	✓	✓	200mm coatback of FS712 Intucoat 2mm WFT
✓	✓	✓	≤ 159	≥ 2	✓	✓	60	60	✓	✓		✓		500mm extension (2 rows) of 2 layers of FI025 Intuflex, sealed to FB750 Intubatt with FS702 Intumastic
✓	✓	✓	≤ 22	≥ 1	✓	✓	120	15	✓	✓	✓	✓	✓	200mm coatback of FS712 Intucoat 2mm WFT
#Up to maximum 14.2 mm														



Appendix UL-EU CERTIFICATE

Certificate No. UL-EU-01058-CPR
Page 73/144
Date of Issue 2017-10-27

Non-Combustible Pipes – Single Batt Compression (Asymmetric)

Uninsulated Non-Combustible Pipes through Flexible and Rigid Walls as identified below, protected by single compressed asymmetric FB750 Intubatt seal, sealed with FS702 Intumastic or FS712 Intucoat.

Wall Details: Flexible or Rigid Walls including Concrete, Brick / Blockwork & AAC, of minimum thickness as identified below, and with performance classified to EN 13501-2.

Flexible Walls constructed from steel or timber faced studs with a minimum of 2 x 12.5mm EN 520 type F boards on each side of studs.

Maximum Opening size: 400mm by 400mm. In Flexible Walls openings should be created using a steel frame with a plasterboard lining. Multiple openings must be separated by a minimum of 200mm for fire resistance requirements. Check separation requirements with the system owner of the supporting construction.

Installation Instructions: Single Layer board, compressed and bonded into the aperture on the opposite side of the wall to the fire. FB750 Intubatt should be installed in as few cut pieces as possible and tightly compressed to two opposite sides. This is achieved by the addition of 2mm to the required cut dimension. Compression may be applied - FB750 Intubatt to FB750 Intubatt, FB750 Intubatt to non-combustible service, or FB750 Intubatt to Substrate. Compression must be achieved over a minimum 60% of the FB750 Intubatt length. If compression is achieved Top to bottom of FB750 Intubatt, left/right is not required to be compressed and vice versa (the non-compressed seal should be fully abutted and bonded). All joints are to be bonded using FS712 Intucoat to full width of the FB750 Intubatt or FS702 Intumastic applied as a 10mm bead along the full-length joint centre line. FS702 Intumastic should be used to point all service and substrate interfaces, to a minimum of a 6mm bead. Apertures for penetrating services are to be tightly fitted and sealed. Imperfections should be filled with FS702 Intumastic to the full depth of the FB750 Intubatt. Service openings should be cut no more than 15mm away from non-combustible services, and/or, openings should be cut to suit the requirements of any additional required Nullfire product, if the service type is combustible or insulated CS or LS. (Imperfections in cut on a compressed edge may not exceed 40% of the area available to receive compression)

The results below are also applicable when using multiple layers of FB750 Intubatt, including 1 layer (or more) of surface mounted FB750 Intubatt.

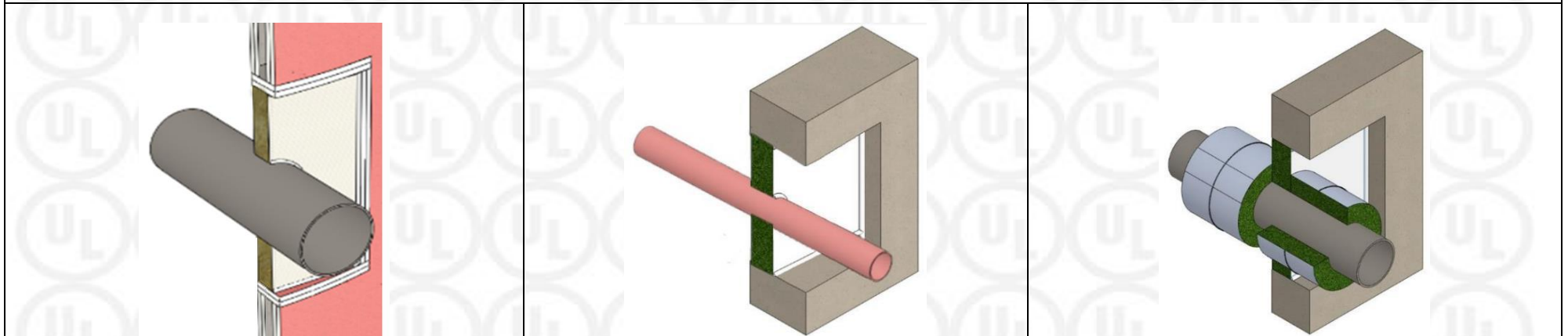

Form-ULID-006104 (DCS:27-CP-F0855) 5.0



Appendix UL-EU CERTIFICATE

Certificate No. UL-EU-01058-CPR
 Page 74/144
 Date of Issue 2017-10-27

Service				Pipe Diameter	Pipe Wall Thickness#	Pipe End Configuration		Integrity	Integrity & Insulation	Rigid Wall Thickness (mm)	Flexible Wall Thickness (mm)	Additional Requirements (Both Sides)
Cast Iron	Steel	Copper	-	(mm)	(mm)	C/C	C/U	E (mins)	EI (mins)	≥ 100	≥ 100	
✓	✓	✓	(*)	≤ 28	≥ 1	✓	✓	60	60	✓	✓	200mm extension of 1 layer of FI025 Intuflex, sealed to FB750 Intubatt with FS702 Intumastic
✓	✓	✓	(*)	≤ 42	≥ 1	✓	✓	60	30	✓	✓	200mm extension of 1 layer of FI025 Intuflex, sealed to FB750 Intubatt with FS702 Intumastic
✓	✓	✓		≤ 28	≥ 1	✓	✓	60	30	✓	✓	-
✓	✓	✓		≤ 160	≥ 1	✓	✓	60	15	✓	✓	220mm extension of 2 layers of FI025 Intuflex, sealed within FB750 Intubatt with FS702 Intumastic

(*) Includes horizontal pipes from 90° to 45° to supporting construction
 #Up to maximum 14.2 mm



Appendix UL-EU CERTIFICATE

Certificate No. UL-EU-01058-CPR
Page 75/144
Date of Issue 2017-10-27

Non-Combustible Pipes in Shafts – Double Batt Pattress & Compression

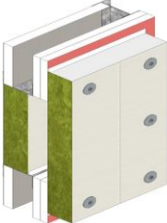
<p>Non-Combustible Pipes through Flexible and Rigid Shaft Walls as identified below, protected by double FB750 Intubatt seal, requiring access from one side only to construct. The first batt is installed flush with the surface furthest from the installation side. The second batt is surface mounted on the installation side, sealed with FS702 Intumastic or FS712 Intucoat. Results apply for fire in either direction.</p>
<p>Wall Details: Flexible or Rigid Walls including Concrete, Brick / Blockwork & AAC, of minimum thickness as identified below, and with performance classified to EN 13501-2. Flexible Walls constructed from steel or studs with a minimum of 1 x 19mm EN 520 type F board on the far side, and 2 x 15mm EN 520 type F boards on the installation side of the studs.</p>
<p>Maximum Opening size: 2010mm by 1000mm. Multiple openings must be separated by a minimum of 200mm for fire resistance requirements. Check separation requirements with the system owner of the supporting construction.</p>
<p>Installation Instructions: A 10mm bead of FS702 should be applied to the perimeter of the opening at the furthest point. The first board is then compressed, bonded, and located on the perimeter bead, within the opening. This FB750 Intubatt should be installed in as few cut pieces as possible and tightly compressed to two opposite sides. This is achieved by the addition of 2mm to the required cut dimension. Compression may be applied - FB750 Intubatt to FB750 Intubatt, FB750 Intubatt to non-combustible service, or FB750 Intubatt to Substrate. Compression must be achieved over a minimum 60% of the FB750 Intubatt Compressed edge. If compression of FB750 Intubatt is achieved between two opposite sides, the perpendicular sides are not required to be compressed (the non-compressed seal should be fully abutted and bonded). All joints are to be bonded using FS712 Intucoat to full width of the FB750 Intubatt or FS702 Intumastic applied as a 10mm bead along the full-length joint centre line. The second board is surface mounted on installation side of the wall with a minimum 75mm overlap around the opening. (Overlap on the lowest edge can be reduced to 30mm in the event of an obstruction preventing the 75mm overlap). The overlap should be bonded with a 10mm bead of FS702 Intumastic placed 20-60mm from the board edges, and additionally mechanically restrained using 75mm steel screws with a 25mm washer at maximum 300mm centres, 10-65mm from the board perimeter and no more than 50mm from a board joint. A low torque setting should be used to ensure that the embedment of fixing into the board does not exceed 15mm. The fixings may be left exposed or covered using FS702 Intumastic. This FB750 Intubatt should also be installed in as few cut pieces as possible. All joints are to be bonded using FS712 Intucoat to full width of the FB750 Intubatt or FS702 Intumastic applied as a 10mm bead along the full-length joint centre line. FS702 Intumastic should be used to point all service and substrate interfaces, to a minimum of a 6mm bead. Apertures for penetrating services are to be tightly fitted and sealed. Imperfections should be filled with FS702 Intumastic to the full depth of the FB750 Intubatt. Service openings should be cut no more than 15mm away from non-combustible services, and/or, openings should be cut to suit the requirements of any additional required Nullifire product, if the service type is combustible or insulated CS or LS. External sides of the Board may be required to be coated for aesthetic reasons or to prevent fibre migration. (In situations where the required overlap cannot be achieved due to a perpendicular fire resisting wall / soffit, it is possible to reduce the overlap, down to as low as 0mm, provided the board edge is bonded to the adjoining compartment using a 10mm bead of FS702 Intumastic, and subsequently pointed to all mated edges)</p>
<p>The results below are also applicable when using multiple layers of surface mounted FB750 Intubatt. For multiple layers of FB750 Intubatt so a single (or both) face, identically sized boards should be used, ideally with staggered joints where possible. Closing devices should be located in or on the outmost board. Board to board abutment should be bonded with 10mm bead of FS702 Intumastic and mechanically restrained using a 75mm spiral screw to the first and secured layer. Spiral fixings should be at max 200mm centres and no more than 50mm from any joint.</p>

Form-ULID-006104 (DCS:27-CP-F0855) 5.0



Appendix UL-EU CERTIFICATE

Certificate No. UL-EU-01058-CPR

Page 76/144

Date of Issue 2017-10-27

Service				Pipe Diameter	Pipe Wall Thickness#	Pipe End Configuration		Integrity	Integrity & Insulation	Flexible Asymmetric Shaft Wall Thickness (mm)	Additional Requirements
Cast Iron	Steel	Copper	-	(mm)	(mm)	C/C	C/U	E (mins)	EI (mins)	≥ 90	
✓	✓	✓	(*)	≤ 14	≥ 1.2	✓	✓	120	120	✓	200mm extension of 1 layer of FI025 Intuflex, sealed to FB750 Intubatt with FS702 Intumastic
✓	✓	✓	(*)	≤ 28	≥ 1.2	✓	✓	120	120	✓	200mm extension of 1 layer of FI025 Intuflex, sealed to FB750 Intubatt with FS702 Intumastic
✓	✓	✓	(*)	≤ 42	≥ 1.2	✓	✓	120	90 (120*)	✓	200mm extension of 1 layer of FI025 Intuflex, sealed to FB750 Intubatt with FS702 Intumastic
✓	✓	✓		≤ 160	≥ 1.2	✓	✓	120	30 (60*)	✓	500mm extension of 2 layers of FI025 Intuflex, sealed to FB750 Intubatt with FS702 Intumastic
✓	✓	✓		≤ 14	≥ 1.2	✓	✓	120	30	✓	-
✓	✓	✓		≤ 28	≥ 1.2	✓	✓	30 (120**)	30	✓	-

(* Includes horizontal pipes from 90° to 45° to supporting construction

All results apply for fire in either direction.

(60*) Result can be increased to EI60 for fire case into shaft

(120*) Result can be increased to EI120 for fire case into shaft

(120**) Result can be increased to EI120 for fire case from shaft into room

#Up to maximum 14.2 mm



Appendix UL-EU CERTIFICATE

Certificate No. UL-EU-01058-CPR
Page 77/144
Date of Issue 2017-10-27

Non-Combustible Pipes Insulated CI – Double Batt Pattress

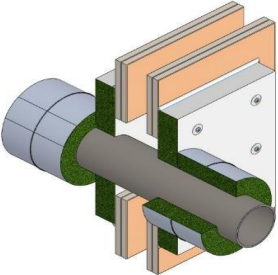
Non-Combustible Pipes Insulated with Continuous Interrupted Insulation passing through Flexible and Rigid Walls as identified below, protected by double pattress (surface mounted) FB750 Intubatt seal, sealed with FS702 Intumastic or FS712 Intucoat.
Wall Details: Flexible or Rigid Walls including Concrete, Brick / Blockwork & AAC, of minimum thickness as identified below, and with performance classified to EN 13501-2. Flexible Walls constructed from steel or timber faced studs with a minimum of 2 x 12.5mm EN 520 type F boards on each side of studs.
Maximum Opening size: 1000mm by 1000mm. Multiple openings must be separated by a minimum of 200mm for fire resistance requirements. Check separation requirements with the system owner of the supporting construction.
Installation Instructions: Boards surface mounted (pattress fit) on both sides of the wall with a minimum 75mm overlap around the opening. (Overlap on the lowest edge can be reduced to 30mm in the event of an obstruction preventing the 75mm overlap). The overlap should be bonded with a 10mm bead of FS702 Intumastic placed 20-60mm from the board edges, and additionally mechanically restrained using 75mm steel screws with a 25mm washer at maximum 300mm centres, 10-65mm from the board perimeter and no more than 50mm from a board joint. A low torque setting should be used to ensure that the embedment of fixing into the board does not exceed 15mm. The fixings may be left exposed or covered using FS702 Intumastic. The FB750 Intubatt should be installed in as few cut pieces as possible. All joints are to be bonded using FS712 Intucoat to full width of the FB750 Intubatt or FS702 Intumastic applied as a 10mm bead along the full-length joint centre line. FS702 Intumastic should be used to point all service and substrate interfaces, to a minimum of a 6mm bead. Apertures for penetrating services are to be tightly fitted and sealed. Imperfections should be filled with FS702 Intumastic to the full depth of the FB750 Intubatt. Service openings should be cut no more than 15mm away from non-combustible services, and/or, openings should be cut to suit the requirements of any additional required Nullifire product, if the service type is combustible or insulated CS or LS. External sides of the Board may be required to be coated for aesthetic reasons or to prevent fibre migration. (In situations where the required overlap cannot be achieved due to a perpendicular fire resisting wall / soffit, it is possible to reduce the overlap, down to as low as 0mm, provided the board edge is bonded to the adjoining compartment using a 10mm bead of FS702 Intumastic, and subsequently pointed to all mated edges)
The results below are also applicable when using multiple layers of surface mounted FB750 Intubatt. For multiple layers of FB750 Intubatt so a single (or both) face, identically sized boards should be used, ideally with staggered joints where possible. Closing devices should be located in or on the outmost board. Board to board abutment should be bonded with 10mm bead of FS702 Intumastic and mechanically restrained using a 75mm spiral screw to the first and secured layer. Spiral fixings should be at max 200mm centres and no more than 50mm from any joint.

Form-ULID-006104 (DCS:27-CP-F0855) 5.0



Appendix UL-EU CERTIFICATE

Certificate No. UL-EU-01058-CPR

Page 78/144

Date of Issue 2017-10-27

Service			CI Pipe Insulation (Continuous Interrupted)		Pipe Diameter	Pipe Wall Thickness#	Pipe End Configuration		Integrity	Integrity & Insulation	Rigid Wall Thickness (mm)		Flexible Wall Thickness (mm)		Additional Requirements
Cast Iron	Steel	Copper	Material	Thickness (mm)	(mm)	(mm)	C/C	C/U	E (mins)	EI (mins)	≥ 130	≥ 100	≥ 130	≥ 100	
✓	✓	✓	Rock Fibre	≥ 30	≤ 159	≥ 2	✓	✓	120	120	✓		✓		-
✓	✓	✓	Rock Fibre	≥ 30	≤ 22	≥ 0.9	✓	✓	120	90	✓		✓		-
✓	✓	✓	Rock Fibre	≥ 30	≤ 15	≥ 0.7	✓	✓	120	90	✓		✓		-
✓	✓	✓	PIR / Phenolic	25	≤ 22	≥ 1	✓	✓	120	60	✓	✓	✓	✓	-
✓	✓	✓	Glass Fibre / Rock Fibre	≥ 40	≤ 22	≥ 1	✓	✓	120	60	✓	✓	✓	✓	-
✓	✓		Rock Fibre	≥ 40	≤ 200	≥ 7.5	✓	✓	120	120	✓		✓		-
✓	✓		Rock Fibre	≥ 30	≤ 60	≥ 7	✓	✓	120	120	✓		✓		-
✓	✓		Nitrile (Elastomeric)	20	≤ 90	≥ 3	✓	✓	120	30	✓	✓	✓	✓	-

#Up to maximum 14.2 mm



Appendix UL-EU CERTIFICATE

Certificate No. UL-EU-01058-CPR
Page 79/144
Date of Issue 2017-10-27

Non-Combustible Pipes Insulated CI – Double Batt Compression

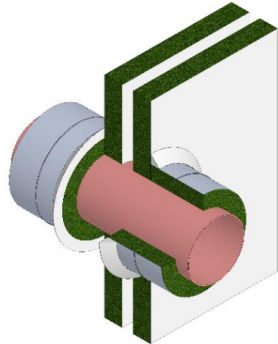
Non-Combustible Pipes Insulated with Continuous Interrupted Insulation passing through Flexible and Rigid Walls as identified below, protected by double compressed FB750 Intubatt seal, sealed with FS702 Intumastic or FS712 Intucoat.
Wall Details: Flexible or Rigid Walls including Concrete, Brick / Blockwork & AAC, of minimum thickness as identified below, and with performance classified to EN 13501-2. Flexible Walls constructed from steel or timber faced studs with a minimum of 2 x 12.5mm EN 520 type F boards on each side of studs.
Maximum Opening size: 1200mm by 1200mm. In Flexible Walls openings should be created using a steel frame. Multiple openings must be separated by a minimum of 200mm for fire resistance requirements. Check separation requirements with the system owner of the supporting construction.
Installation Instructions: Double Layer board, compressed and bonded into the aperture outer face flush with the face of the supporting construction. FB750 Intubatt should be installed in as few cut pieces as possible and tightly compressed to two opposite sides. This is achieved by the addition of 2mm to the required cut dimension. Compression may be applied - FB750 Intubatt to FB750 Intubatt, FB750 Intubatt to non-combustible service, or FB750 Intubatt to Substrate. Compression must be achieved over a minimum 60% of the FB750 Intubatt compressed edge. If compression is achieved Top to bottom of FB750 Intubatt, left/right is not required to be compressed and vice versa (the non-compressed seal should be fully abutted and bonded). All joints are to be bonded using FS712 Intucoat to full width of the FB750 Intubatt or FS702 Intumastic applied as a 10mm bead along the full-length joint centre line. FS702 Intumastic should be used to point all service and substrate interfaces, to a minimum of a 6mm bead. Apertures for penetrating services are to be tightly fitted and sealed. Imperfections should be filled with FS702 Intumastic to the full depth of the FB750 Intubatt. Service openings should be cut no more than 15mm away from non-combustible services, and/or, openings should be cut to suit the requirements of any additional required Nullifire product, if the service type is combustible or insulated CS or LS. (Imperfections in cut on a compressed edge may not exceed 40% of the area available to receive compression)
The results below are also applicable when using multiple layers of FB750 Intubatt, including 1 layer (or more) surface mounted on both sides of the wall.

Form-ULID-006104 (DCS:27-CP-F0855) 5.0



Appendix UL-EU CERTIFICATE

Certificate No. UL-EU-01058-CPR
 Page 80/144
 Date of Issue 2017-10-27

Service			CI Pipe Insulation (Continuous Interrupted)		Pipe Diameter	Pipe Wall Thickness#	Pipe End Configuration		Integrity	Integrity & Insulation	Rigid Wall Thickness (mm)		Flexible Wall Thickness (mm)		Additional Requirements
Cast Iron	Steel	Copper	Material	Thickness (mm)	(mm)	(mm)	C/C	C/U	E (mins)	EI (mins)	≥ 130	≥ 100	≥ 130	≥ 100	
✓	✓		Rock Fibre	≥ 40	≤ 200	≥ 7.5	✓	✓	120	120	✓		✓		-
✓	✓		Rock Fibre	≥ 30	≤ 60	≥ 7	✓	✓	120	120	✓		✓		-
✓	✓		Nitrile (Elastomeric)	20	≤ 90	≥ 3	✓	✓	120	30	✓	✓	✓	✓	-
✓	✓	✓	Rock Fibre	≥ 30	≤ 22	≥ 0.9	✓	✓	120	90	✓		✓		-
✓	✓	✓	Rock Fibre	≥ 30	≤ 15	≥ 0.7	✓	✓	120	90	✓		✓		-
✓	✓	✓	PIR / Phenolic	25	≤ 22	≥ 1	✓	✓	120	60	✓	✓	✓	✓	-
✓	✓	✓	Glass Fibre / Rock Fibre	≥ 40	≤ 22	≥ 1	✓	✓	120	60	✓	✓	✓	✓	-
✓	✓	✓	Rock Fibre	≥ 30	≤ 159	≥ 2	✓	✓	60	60	✓		✓		-

#Up to maximum 14.2 mm



Appendix UL-EU CERTIFICATE

Certificate No. UL-EU-01058-CPR
Page 81/144
Date of Issue 2017-10-27

Non-Combustible Pipes Insulated CI – Single Batt Compression

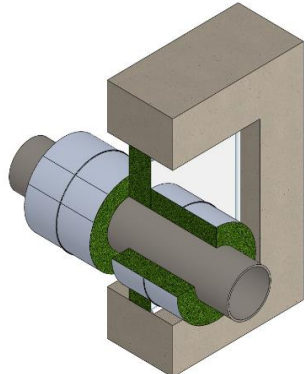
Non-Combustible Pipes Insulated with Continuous Interrupted Insulation passing through Flexible and Rigid Walls as identified below, protected by single compressed FB750 Intubatt seal, sealed with FS702 Intumastic or FS712 Intucoat.
Wall Details: Flexible or Rigid Walls including Concrete, Brick / Blockwork & AAC, of minimum thickness as identified below, and with performance classified to EN 13501-2. Flexible Walls constructed from steel or timber faced studs with a minimum of 2 x 12.5mm EN 520 type F boards on each side of studs.
Maximum Opening size: 1800mm by 1200mm. In Flexible Walls openings should be created using a steel frame with a plasterboard lining. Multiple openings must be separated by a minimum of 200mm for fire resistance requirements. Check separation requirements with the system owner of the supporting construction.
Installation Instructions: Single Layer board, compressed and bonded into the aperture at mid depth of the wall. FB750 Intubatt should be installed in as few cut pieces as possible and tightly compressed to two opposite sides. This is achieved by the addition of 2mm to the required cut dimension. Compression may be applied - FB750 Intubatt to FB750 Intubatt, FB750 Intubatt to non-combustible service, or FB750 Intubatt to Substrate. Compression must be achieved over a minimum 60% of the FB750 Intubatt Compressed edge. If compression is achieved Top to bottom of FB750 Intubatt, left/right is not required to be compressed and vice versa (the non-compressed seal should be fully abutted and bonded). All joints are to be bonded using FS712 Intucoat to full width of the FB750 Intubatt or FS702 Intumastic applied as a 10mm bead along the full-length joint centre line. FS702 Intumastic should be used to point all service and substrate interfaces, to a minimum of a 6mm bead. Apertures for penetrating services are to be tightly fitted and sealed. Imperfections should be filled with FS702 Intumastic to the full depth of the FB750 Intubatt. Service openings should be cut no more than 15mm away from non-combustible services, and/or, openings should be cut to suit the requirements of any additional required Nullifire product, if the service type is combustible or insulated CS or LS. (Imperfections in cut on a compressed edge may not exceed 40% of the area available to receive compression)
The results below are also applicable when using multiple layers of FB750 Intubatt, including 1 layer (or more) surface mounted on both sides of the wall.

Form-ULID-006104 (DCS:27-CP-F0855) 5.0



Appendix UL-EU CERTIFICATE

Certificate No. UL-EU-01058-CPR
 Page 82/144
 Date of Issue 2017-10-27

Service			CI Pipe Insulation (Continuous Interrupted)		Pipe Diameter	Pipe Wall Thickness#	Pipe End Configuration		Integrity	Integrity & Insulation	Rigid Wall Thickness (mm)		Flexible Wall Thickness (mm)		Additional Requirements
Cast Iron	Steel	Copper	Material	Thickness (mm)	(mm)	(mm)	C/C	C/U	E (mins)	EI (mins)	≥ 130	≥ 100	≥ 130	≥ 100	
✓	✓	✓	Rock Fibre	≥ 40	≤ 15	≥ 1	✓	✓	120	90	✓		✓		-
✓	✓	✓	PIR / Phenolic	25	≤ 22	≥ 1	✓	✓	120	60	✓	✓	✓	✓	-
✓	✓	✓	Glass Fibre / Rock Fibre	≥ 40	≤ 22	≥ 1	✓	✓	120	60	✓	✓	✓	✓	-
✓	✓	✓	Rock Fibre	≥ 30	≤ 159	≥ 2	✓	✓	60	60	✓		✓		-
✓	✓		Nitrile (Elastomeric)	20	≤ 90	≥ 3	✓	✓	120	30	✓	✓	✓	✓	-
#Up to maximum 14.2 mm															



Appendix UL-EU CERTIFICATE

Certificate No. UL-EU-01058-CPR
 Page 83/144
 Date of Issue 2017-10-27

Non-Combustible Pipes Insulated CS – Double Batt Pattress

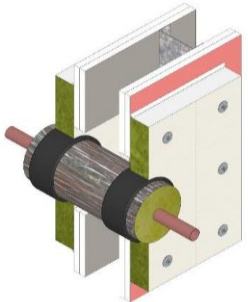
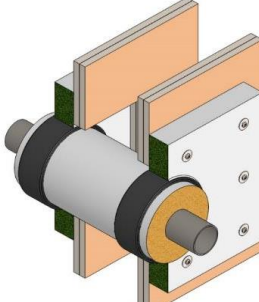
<p>Non-Combustible Pipes Insulated with Continuous Sustained Insulation passing through Flexible and Rigid Walls as identified below, protected by double pattress (surface mounted) FB750 Intubatt seal, sealed with FS702 Intumastic or FS712 Intucoat.</p>	
<p>Wall Details: Flexible or Rigid Walls including Concrete, Brick / Blockwork & AAC, of minimum thickness as identified below, and with performance classified to EN 13501-2. Flexible Walls constructed from steel or timber faced studs with a minimum of 2 x 12.5mm EN 520 type F boards on each side of studs.</p>	
<p>Maximum Opening size: 2000mm by 1100mm. Multiple openings must be separated by a minimum of 200mm for fire resistance requirements. Check separation requirements with the system owner of the supporting construction.</p>	
<p>Installation Instructions: Boards surface mounted (pattress fit) on both sides of the wall with a minimum 75mm overlap around the opening. (Overlap on the lowest edge can be reduced to 30mm in the event of an obstruction preventing the 75mm overlap). The overlap should be bonded with a 10mm bead of FS702 Intumastic placed 20-60mm from the board edges, and additionally mechanically restrained using 75mm steel screws with a 25mm washer at maximum 300mm centres, 10-65mm from the board perimeter and no more than 50mm from a board joint. A low torque setting should be used to ensure that the embedment of fixing into the board does not exceed 15mm. The fixings may be left exposed or covered using FS702 Intumastic. The FB750 Intubatt should be installed in as few cut pieces as possible. All joints are to be bonded using FS712 Intucoat to full width of the FB750 Intubatt or FS702 Intumastic applied as a 10mm bead along the full-length joint centre line. FS702 Intumastic should be used to point all service and substrate interfaces, to a minimum of a 6mm bead. Apertures for penetrating services are to be tightly fitted and sealed. Imperfections should be filled with FS702 Intumastic to the full depth of the FB750 Intubatt. Service openings should be cut no more than 15mm away from non-combustible services, and/or, openings should be cut to suit the requirements of any additional required Nullifire product, if the service type is combustible or insulated CS or LS. External sides of the Board may be required to be coated for aesthetic reasons or to prevent fibre migration. (In situations where the required overlap cannot be achieved due to a perpendicular fire resisting wall / soffit, it is possible to reduce the overlap, down to as low as 0mm, provided the board edge is bonded to the adjoining compartment using a 10mm bead of FS702 Intumastic, and subsequently pointed to all mated edges)</p>	
<p>The results below are also applicable when using multiple layers of surface mounted FB750 Intubatt. For multiple layers of FB750 Intubatt so a single (or both) face, identically sized boards should be used, ideally with staggered joints where possible. Closing devices should be located in or on the outmost board. Board to board abutment should be bonded with 10mm bead of FS702 Intumastic and mechanically restrained using a 75mm spiral screw to the first and secured layer. Spiral fixings should be at max 200mm centres and no more than 50mm from any joint.</p>	
	

Form-ULID-006104 (DCS:27-CP-F0855) 5.0



Appendix UL-EU CERTIFICATE

Certificate No. UL-EU-01058-CPR
 Page 84/144
 Date of Issue 2017-10-27

Service				CS Pipe Insulation (Continuous Sustained)		Pipe Diameter	Pipe Wall Thickness#	Pipe End Configuration		Integrity	Integrity & Insulation	Rigid Wall Thickness (mm)				Flexible Wall Thickness (mm)		Additional Requirements (Both Sides)
Cast Iron	Steel	Copper	-	Material	Thickness (mm)	(mm)	(mm)	C/C	C/U	E (mins)	EI (mins)	≥ 145	≥ 130	≥ 100	≥ 90	≥ 130	≥ 100	
✓	✓	✓		PIR / Phenolic	20	≤ 14	≥ 1.2	✓	✓	120	120	✓	✓	✓		✓	✓	2 layers of FP302 Intustrap, sealed within FB750 Intubatt with FS702 Intumastic
✓	✓	✓	(*)	PIR / Phenolic	50	≤ 28	≥ 1.2	✓	✓	120	120	✓	✓	✓		✓	✓	20mm annulus of FS709 HP Intumescent Sealant, 50mm depth
✓	✓	✓	(*)	PIR / Phenolic	20	≤ 14	≥ 1.2	✓	✓	120	120	✓	✓	✓		✓	✓	20mm annulus of FS709 HP Intumescent Sealant, 50mm depth
✓	✓	✓		PIR / Phenolic	30	≤ 22	≥ 1.2	✓	✓	120	120	✓	✓	✓				25mm annulus of FS709 HP Intumescent Sealant, 25mm depth, with a central rock fibre backing
✓	✓	✓		PIR / Phenolic	20	≤ 22	≥ 0.7	✓	✓	120	120	✓	✓	✓		✓	✓	2 layers of FP302 Intustrap, sealed within FB750 Intubatt with FS702 Intumastic
✓	✓	✓		Glass fibre	≥ 50	≤ 15	≥ 1	✓	✓	120	120	✓	✓			✓		2 layers of FP302 Intustrap, sealed within FB750 Intubatt with FS702 Intumastic
✓	✓	✓		Glass fibre	≥ 25	≤ 22	≥ 0.7	✓	✓	120	120	✓	✓	✓		✓	✓	2 layers of FP302 Intustrap, sealed within FB750 Intubatt with FS702 Intumastic



Appendix UL-EU CERTIFICATE

Certificate No. UL-EU-01058-CPR
 Page 85/144
 Date of Issue 2017-10-27

Service				CS Pipe Insulation (Continuous Sustained)		Pipe Diameter	Pipe Wall Thickness#	Pipe End Configuration		Integrity	Integrity & Insulation	Rigid Wall Thickness (mm)				Flexible Wall Thickness (mm)		Additional Requirements (Both Sides)
Cast Iron	Steel	Copper	-	Material	Thickness (mm)	(mm)	(mm)	C/C	C/U	E (mins)	EI (mins)	≥ 145	≥ 130	≥ 100	≥ 90	≥ 130	≥ 100	
✓	✓	✓		Nitrile (Elastomeric)	35	≤ 15	≥ 1	✓	✓	120	120	✓	✓			✓		2 layers of FP302 Intustrap, sealed within FB750 Intubatt with FS702 Intumastic
✓	✓	✓		Nitrile (Elastomeric)	15	≤ 22	≥ 0.7	✓	✓	120	120	✓	✓	✓		✓	✓	2 layers of FP302 Intustrap, sealed within FB750 Intubatt with FS702 Intumastic
✓	✓	✓		PIR / Phenolic	50	≤ 28	≥ 1.2	✓	✓	120	90	✓	✓	✓		✓	✓	2 layers of FP302 Intustrap, sealed within FB750 Intubatt with FS702 Intumastic
✓	✓	✓		PIR / Phenolic	20	≤ 28	≥ 1.2	✓	✓	120	90	✓	✓	✓		✓	✓	2 layers of FP302 Intustrap, sealed within FB750 Intubatt with FS702 Intumastic
✓	✓	✓		PIR / Phenolic	20	≤ 28	≥ 1.2	✓	✓	120	90	✓	✓	✓		✓	✓	20mm annulus of FS709 HP Intumescent Sealant, 50mm depth
✓	✓	✓	(*)	PIR / Phenolic	20	≤ 48	≥ 1.2	✓	✓	120	90	✓	✓	✓		✓	✓	20mm annulus of FS709 HP Intumescent Sealant, 50mm depth
✓	✓	✓		PIR / Phenolic	50	≤ 42	≥ 1.2	✓	✓	120	30	✓	✓	✓		✓	✓	2 layers of FP302 Intustrap, sealed within FB750 Intubatt with FS702 Intumastic



Appendix UL-EU CERTIFICATE

Certificate No. UL-EU-01058-CPR
 Page 86/144
 Date of Issue 2017-10-27

Service				CS Pipe Insulation (Continuous Sustained)		Pipe Diameter	Pipe Wall Thickness#	Pipe End Configuration		Integrity	Integrity & Insulation	Rigid Wall Thickness (mm)				Flexible Wall Thickness (mm)		Additional Requirements (Both Sides)
Cast Iron	Steel	Copper	-	Material	Thickness (mm)	(mm)	(mm)	C/C	C/U	E (mins)	EI (mins)	≥ 145	≥ 130	≥ 100	≥ 90	≥ 130	≥ 100	
✓	✓	✓		PIR / Phenolic	20	≤ 42	≥ 1.2	✓	✓	120	30	✓	✓	✓		✓	✓	2 layers of FP302 Intustrap, sealed within FB750 Intubatt with FS702 Intumastic

#Up to maximum 14.2 mm



Appendix UL-EU CERTIFICATE

Certificate No. UL-EU-01058-CPR
 Page 87/144
 Date of Issue 2017-10-27

Service				CS Pipe Insulation (Continuous Sustained)		Pipe Diameter	Pipe Wall Thickness#	Pipe End Configuration		Integrity	Integrity & Insulation	Rigid Wall Thickness (mm)				Flexible Wall Thickness (mm)		Additional Requirements (Both Sides)
Cast Iron	Steel	Copper	-	Material	Thickness (mm)	(mm)	(mm)	C/C	C/U	E (mins)	EI (mins)	≥ 145	≥ 130	≥ 100	≥ 90	≥ 130	≥ 100	
✓	✓	✓		Rock Fibre	≥ 40	≤ 15	≥ 0.7	✓	✓	90	90	✓	✓	✓		✓	✓	-
✓	✓	✓		Rock Fibre	≥ 40	≤ 159	≥ 2	✓	✓	90	90	✓	✓	✓		✓	✓	-
✓	✓	✓		Rock Fibre	≥ 30	≤ 159	≥ 2	✓	✓	90	60	✓	✓	✓		✓	✓	-
✓	✓	✓		Glass fibre	≥ 50	≤ 22	≥ 0.9	✓	✓	90	30	✓	✓	✓	✓			2 layers of FP302 Intustrap, sealed within FB750 Intubatt with FS702 Intumastic
✓	✓	✓		PIR / Phenolic	30	≤ 22	≥ 0.9	✓	✓	90	30	✓	✓	✓	✓			2 layers of FP302 Intustrap, sealed within FB750 Intubatt with FS702 Intumastic
✓	✓	✓		PIR / Phenolic	30	≤ 22	≥ 0.9	✓	✓	90	30	✓	✓	✓	✓			2 layers of FP302 Intustrap, sealed within FB750 Intubatt with FS702 Intumastic
✓	✓	✓	(*)	PIR / Phenolic	50	≤ 42	≥ 1.2	✓	✓	60	30	✓	✓	✓		✓	✓	20mm annulus of FS709 HP Intumescent Sealant, 50mm depth
✓	✓			Glass Fibre	≥ 25	≤ 60	≥ 3.3	✓	✓	120	120	✓	✓					2 layers of FP302 Intustrap, sealed within FB750 Intubatt with FS702 Intumastic



Appendix UL-EU CERTIFICATE

Certificate No. UL-EU-01058-CPR
 Page 88/144
 Date of Issue 2017-10-27

Service				CS Pipe Insulation (Continuous Sustained)		Pipe Diameter	Pipe Wall Thickness#	Pipe End Configuration		Integrity	Integrity & Insulation	Rigid Wall Thickness (mm)				Flexible Wall Thickness (mm)		Additional Requirements (Both Sides)
Cast Iron	Steel	Copper	-	Material	Thickness (mm)	(mm)	(mm)	C/C	C/U	E (mins)	EI (mins)	≥ 145	≥ 130	≥ 100	≥ 90	≥ 130	≥ 100	
✓	✓			Glass Fibre	≥ 50	≤ 60	≥ 6	✓	✓	120	120	✓	✓					1 layer of FP302 Intustrap, sealed within FB750 Intubatt with FS702 Intumastic
✓	✓			Glass Fibre	≥ 50	≤ 220	≥ 6	✓	✓	120	90	✓						2 layers of FP302 Intustrap, sealed within FB750 Intubatt with FS702 Intumastic
✓	✓			PIR / Phenolic	30	≤ 22	≥ 1.8	✓	✓	90	90	✓	✓	✓		✓	✓	2 layers of FP302 Intustrap, sealed within FB750 Intubatt with FS702 Intumastic
✓	✓			Nitrile (Elastomeric)	38	≤ 220	≥ 6	✓	✓	120	60	✓						2 layers of FP302 Intustrap, sealed within FB750 Intubatt with FS702 Intumastic
✓	✓			Nitrile (Elastomeric)	25	≤ 22	≥ 1.8	✓	✓	90	30	✓	✓	✓		✓	✓	2 layers of FP302 Intustrap, sealed within FB750 Intubatt with FS702 Intumastic

(*) Includes horizontal pipes from 90° to 45° to supporting construction
 #Up to maximum 14.2 mm



Appendix UL-EU CERTIFICATE

Certificate No. UL-EU-01058-CPR
Page 89/144
Date of Issue 2017-10-27

Non-Combustible Pipes Insulated CS – Double Batt Compression

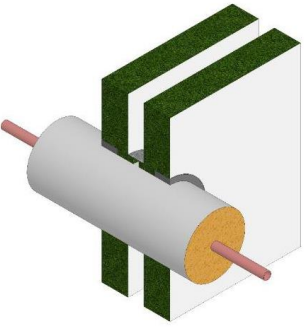
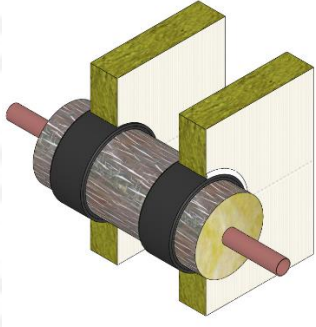
Non-Combustible Pipes Insulated with Continuous Sustained Insulation passing through Flexible and Rigid Walls as identified below, protected by double compressed FB750 Intubatt seal, sealed with FS702 Intumastic or FS712 Intucoat.	
Wall Details: Flexible or Rigid Walls including Concrete, Brick / Blockwork & AAC, of minimum thickness as identified below, and with performance classified to EN 13501-2. Flexible Walls constructed from steel or timber faced studs with a minimum of 2 x 12.5mm EN 520 type F boards on each side of studs.	
Maximum Opening size: 2000mm by 1100mm. In Flexible Walls openings should be created using a steel frame. Multiple openings must be separated by a minimum of 200mm for fire resistance requirements. Check separation requirements with the system owner of the supporting construction.	
Installation Instructions: Double Layer board, compressed and bonded into the aperture outer face flush with the face of the supporting construction. FB750 Intubatt should be installed in as few cut pieces as possible and tightly compressed to two opposite sides. This is achieved by the addition of 2mm to the required cut dimension. Compression may be applied - FB750 Intubatt to FB750 Intubatt, FB750 Intubatt to non-combustible service, or FB750 Intubatt to Substrate. Compression must be achieved over a minimum 60% of the FB750 Intubatt compressed edge. If compression is achieved Top to bottom of FB750 Intubatt, left/right is not required to be compressed and vice versa (the non-compressed seal should be fully abutted and bonded). All joints are to be bonded using FS712 Intucoat to full width of the FB750 Intubatt or FS702 Intumastic applied as a 10mm bead along the full-length joint centre line. FS702 Intumastic should be used to point all service and substrate interfaces, to a minimum of a 6mm bead. Apertures for penetrating services are to be tightly fitted and sealed. Imperfections should be filled with FS702 Intumastic to the full depth of the FB750 Intubatt. Service openings should be cut no more than 15mm away from non-combustible services, and/or, openings should be cut to suit the requirements of any additional required Nullifire product, if the service type is combustible or insulated CS or LS. (Imperfections in cut on a compressed edge may not exceed 40% of the area available to receive compression)	
The results below are also applicable when using multiple layers of FB750 Intubatt, including 1 layer (or more) surface mounted on both sides of the wall.	
	

Form-ULID-006104 (DCS:27-CP-F0855) 5.0



Appendix UL-EU CERTIFICATE

Certificate No. UL-EU-01058-CPR
 Page 90/144
 Date of Issue 2017-10-27

Service				CS Pipe Insulation (Continuous Sustained)		Pipe Diameter	Pipe Wall Thickness#	Pipe End Configuration		Integrity	Integrity & Insulation	Rigid Wall Thickness (mm)		Flexible Wall Thickness (mm)		Additional Requirements (Both Sides)
Cast Iron	Steel	Copper	-	Material	Thickness (mm)	(mm)	(mm)	C/C	C/U	E (mins)	EI (mins)	≥ 130	≥ 100	≥ 130	≥ 100	
✓	✓	✓		PIR / Phenolic	20	≤ 14	≥ 1	✓	✓	120	120	✓	✓	✓	✓	2 layers of FP302 Intustrap, sealed within FB750 Intubatt with FS702 Intumastic
✓	✓	✓	(*)	PIR / Phenolic	50	≤ 28	≥ 1	✓	✓	120	120	✓	✓	✓	✓	20mm annulus of FS709 HP Intumescent Sealant, 50mm depth
✓	✓	✓	(*)	PIR / Phenolic	20	≤ 14	≥ 1	✓	✓	120	120	✓	✓	✓	✓	20mm annulus of FS709 HP Intumescent Sealant, 50mm depth
✓	✓	✓		PIR / Phenolic	30	≤ 22	≥ 1	✓	✓	120	120	✓	✓			25mm annulus of FS709 HP Intumescent Sealant, 25mm depth, with a central 50mm rock fibre backing
✓	✓	✓		Glass fibre	≥ 50	≤ 15	≥ 1	✓	✓	120	120	✓		✓		2 layers of FP302 Intustrap, sealed within FB750 Intubatt with FS702 Intumastic
✓	✓	✓		Nitrile (Elastomeric)	35	≤ 15	≥ 1	✓	✓	120	120	✓		✓		2 layers of FP302 Intustrap, sealed within FB750 Intubatt with FS702 Intumastic
✓	✓	✓		PIR / Phenolic	50	≤ 28	≥ 1	✓	✓	120	90	✓	✓	✓	✓	2 layers of FP302 Intustrap, sealed within FB750 Intubatt with FS702 Intumastic
✓	✓	✓		PIR / Phenolic	20	≤ 28	≥ 1	✓	✓	120	90	✓	✓	✓	✓	2 layers of FP302 Intustrap, sealed within FB750 Intubatt with FS702 Intumastic
✓	✓	✓	(*)	PIR / Phenolic	20	≤ 48	≥ 1	✓	✓	120	90	✓	✓	✓	✓	20mm annulus of FS709 HP Intumescent Sealant, 50mm depth

#Up to maximum 14.2 mm



Appendix UL-EU CERTIFICATE

Certificate No. UL-EU-01058-CPR
 Page 91/144
 Date of Issue 2017-10-27

Service				CS Pipe Insulation (Continuous Sustained)		Pipe Diameter	Pipe Wall Thickness#	Pipe End Configuration		Integrity	Integrity & Insulation	Rigid Wall Thickness (mm)		Flexible Wall Thickness (mm)		Additional Requirements (Both Sides)
Cast Iron	Steel	Copper	-	Material	Thickness (mm)	(mm)	(mm)	C/C	C/U	E (mins)	EI (mins)	≥ 130	≥ 100	≥ 130	≥ 100	
✓	✓	✓		Rock Fibre	≥ 40	≤ 15	≥ 0.7	✓	✓	90	90	✓	✓	✓	✓	-
✓	✓	✓		Rock Fibre	≥ 40	≤ 159	≥ 2	✓	✓	90	90	✓	✓	✓	✓	-
✓	✓	✓		Rock Fibre	≥ 30	≤ 159	≥ 2	✓	✓	90	60	✓	✓	✓	✓	-
✓	✓	✓		PIR / Phenolic	50	≤ 42	≥ 1	✓	✓	120	30	✓	✓	✓	✓	2 layers of FP302 Intustrap, sealed within FB750 Intubatt with FS702 Intumastic
✓	✓	✓		PIR / Phenolic	20	≤ 42	≥ 1	✓	✓	120	30	✓	✓	✓	✓	2 layers of FP302 Intustrap, sealed within FB750 Intubatt with FS702 Intumastic
✓	✓	✓		Nitrile (Elastomeric)	25	≤ 22	≥ 0.9	✓	✓	120	30	✓	✓			2 layers of FP302 Intustrap, sealed within FB750 Intubatt with FS702 Intumastic
✓	✓	✓		Glass fibre	≥ 50	≤ 22	≥ 0.9	✓	✓	90	30	✓	✓			2 layers of FP302 Intustrap, sealed within FB750 Intubatt with FS702 Intumastic
✓	✓	✓		PIR / Phenolic	30	≤ 22	≥ 0.9	✓	✓	90	30	✓	✓			2 layers of FP302 Intustrap, sealed within FB750 Intubatt with FS702 Intumastic
✓	✓	✓	(*)	PIR / Phenolic	50	≤ 42	≥ 1	✓	✓	60	30	✓	✓	✓	✓	20mm annulus of FS709 HP Intumescent Sealant, 50mm depth
✓	✓			PIR / Phenolic	30	≤ 22	≥ 1.8	✓	✓	90	90	✓	✓	✓	✓	2 layers of FP302 Intustrap, sealed within FB750 Intubatt with FS702 Intumastic



Appendix UL-EU CERTIFICATE

Certificate No. UL-EU-01058-CPR
 Page 92/144
 Date of Issue 2017-10-27

Service				CS Pipe Insulation (Continuous Sustained)		Pipe Diameter	Pipe Wall Thickness#	Pipe End Configuration		Integrity	Integrity & Insulation	Rigid Wall Thickness (mm)		Flexible Wall Thickness (mm)		Additional Requirements (Both Sides)
Cast Iron	Steel	Copper	-	Material	Thickness (mm)	(mm)	(mm)	C/C	C/U	E (mins)	EI (mins)	≥ 130	≥ 100	≥ 130	≥ 100	
✓	✓			Nitrile (Elastomeric)	25	≤ 22	≥ 1.8	✓	✓	90	30	✓	✓	✓	✓	2 layers of FP302 Intustrap, sealed within FB750 Intubatt with FS702 Intumastic
✓	✓			Glass fibre	≥ 30	≤ 22	≥ 1.8	✓	✓	90	30	✓	✓	✓	✓	2 layers of FP302 Intustrap, sealed within FB750 Intubatt with FS702 Intumastic

(*) Includes horizontal pipes from 90° to 45° to supporting construction
 #Up to maximum 14.2 mm



Appendix UL-EU CERTIFICATE

Certificate No. UL-EU-01058-CPR

Page 93/144

Date of Issue 2017-10-27

Non-Combustible Pipes Insulated CS – Single Batt Compression

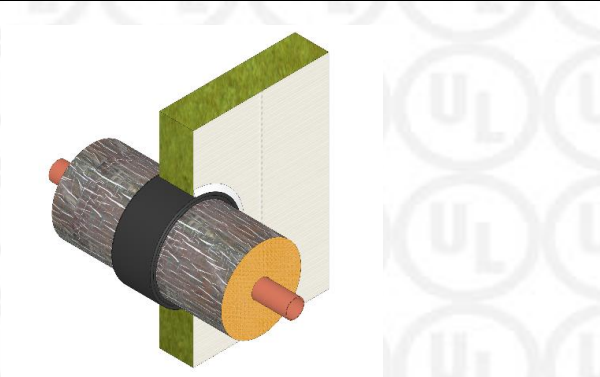
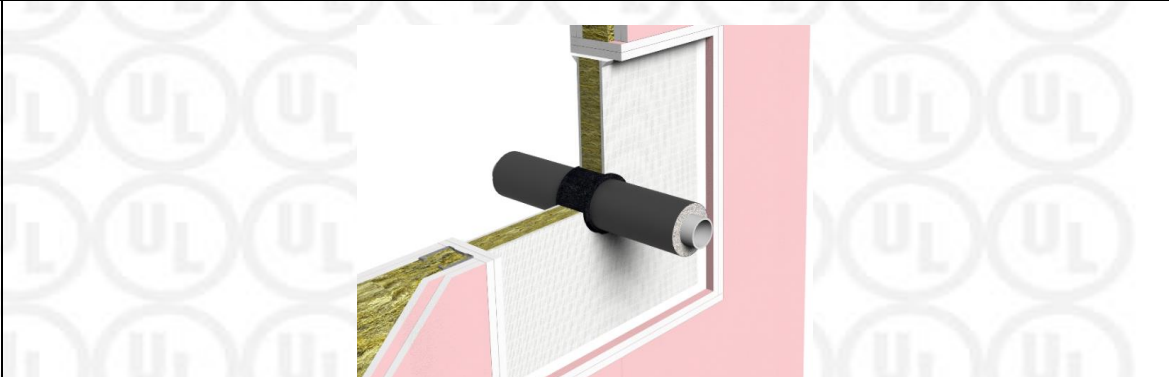
Non-Combustible Pipes Insulated with Continuous Sustained Insulation passing through Flexible and Rigid Walls as identified below, protected by single compressed FB750 Intubatt seal, sealed with FS702 Intumastic or FS712 Intucoat.	
Wall Details: Flexible or Rigid Walls including Concrete, Brick / Blockwork & AAC, of minimum thickness as identified below, and with performance classified to EN 13501-2. Flexible Walls constructed from steel or timber faced studs with a minimum of 2 x 12.5mm EN 520 type F boards on each side of studs.	
Maximum Opening size: 1100mm by 630mm. In Flexible Walls openings should be created using a steel frame with a plasterboard lining. Multiple openings must be separated by a minimum of 200mm for fire resistance requirements. Check separation requirements with the system owner of the supporting construction.	
Installation Instructions: Single Layer board, compressed and bonded into the aperture at mid depth of the wall. FB750 Intubatt should be installed in as few cut pieces as possible and tightly compressed to two opposite sides. This is achieved by the addition of 2mm to the required cut dimension. Compression may be applied - FB750 Intubatt to FB750 Intubatt, FB750 Intubatt to non-combustible service, or FB750 Intubatt to Substrate. Compression must be achieved over a minimum 60% of the FB750 Intubatt Compressed edge. If compression is achieved Top to bottom of FB750 Intubatt, left/right is not required to be compressed and vice versa (the non-compressed seal should be fully abutted and bonded). All joints are to be bonded using FS712 Intucoat to full width of the FB750 Intubatt or FS702 Intumastic applied as a 10mm bead along the full-length joint centre line. FS702 Intumastic should be used to point all service and substrate interfaces, to a minimum of a 6mm bead. Apertures for penetrating services are to be tightly fitted and sealed. Imperfections should be filled with FS702 Intumastic to the full depth of the FB750 Intubatt. Service openings should be cut no more than 15mm away from non-combustible services, and/or, openings should be cut to suit the requirements of any additional required Nullfire product, if the service type is combustible or insulated CS or LS. (Imperfections in cut on a compressed edge may not exceed 40% of the area available to receive compression)	
The results below are also applicable when using multiple layers of FB750 Intubatt, including 1 layer (or more) surface mounted on both sides of the wall.	
	

Form-ULID-006104 (DCS:27-CP-F0855) 5.0



Appendix UL-EU CERTIFICATE

Certificate No. UL-EU-01058-CPR
 Page 94/144
 Date of Issue 2017-10-27

Service			CS Pipe Insulation (Continuous Sustained)		Pipe Diameter	Pipe Wall Thickness#	Pipe End Configuration		Integrity	Integrity & Insulation	Rigid Wall Thickness (mm)	Flexible Wall Thickness (mm)	Additional Requirements
Cast Iron	Steel	Copper	Material	Thickness (mm)	(mm)	(mm)	C/C	C/U	E (mins)	EI (mins)	≥ 100	≥ 100	
✓	✓		PIR / Phenolic	30	≤ 22	≥ 1.8	✓	✓	90	90	✓	✓	2 layers of FP302 Intustrap (central to the seal). sealed on both sides of FB750 Intubatt with FS702 Intumastic
✓	✓		Glass Fibre	≥ 30	≤ 22	≥ 1.8	✓	✓	90	30	✓	✓	2 layers of FP302 Intustrap (central to the seal). sealed on both sides of FB750 Intubatt with FS702 Intumastic
✓	✓	✓	Rock Fibre	≥ 30	≤ 159	≥ 2	✓	✓	90	60	✓	✓	-
✓	✓	✓	Nitrile (Elastomeric)	25	≤ 22	≥ 0.9	✓	✓	120	30	✓		2 layers of FP302 Intustrap (central to the seal). sealed on both sides of FB750 Intubatt with FS702 Intumastic
✓	✓	✓	Glass fibre	≥ 50	≤ 22	≥ 0.9	✓	✓	90	30	✓		2 layers of FP302 Intustrap (central to the seal). sealed on both sides of FB750 Intubatt with FS702 Intumastic



#Up to maximum 14.2 mm



Appendix UL-EU CERTIFICATE

Certificate No. UL-EU-01058-CPR
Page 95/144
Date of Issue 2017-10-27

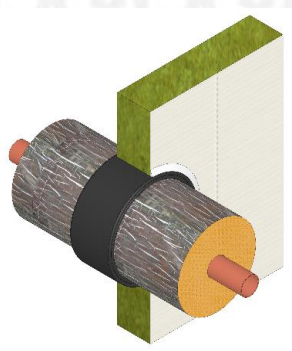
Non-Combustible Pipes Insulated CS – Single Batt Compression (Asymmetric)

Non-Combustible Pipes Insulated with Continuous Sustained Insulation passing through Flexible and Rigid Walls as identified below, protected by single compressed asymmetric FB750 Intubatt seal, sealed with FS702 Intumastic or FS712 Intucoat.	
Wall Details: Flexible or Rigid Walls including Concrete, Brick / Blockwork & AAC, of minimum thickness as identified below, and with performance classified to EN 13501-2. Flexible Walls constructed from steel or timber faced studs with a minimum of 2 x 12.5mm EN 520 type F boards on each side of studs.	
Maximum Opening size: 400mm by 400mm. In Flexible Walls openings should be created using a steel frame with a plasterboard lining. Multiple openings must be separated by a minimum of 200mm for fire resistance requirements. Check separation requirements with the system owner of the supporting construction.	
Installation Instructions: Single Layer board, compressed and bonded into the aperture on the opposite side of the wall to fire. FB750 Intubatt should be installed in as few cut pieces as possible and tightly compressed to two opposite sides. This is achieved by the addition of 2mm to the required cut dimension. Compression may be applied - FB750 Intubatt to FB750 Intubatt, FB750 Intubatt to non-combustible service, or FB750 Intubatt to Substrate. Compression must be achieved over a minimum 60% of the FB750 Intubatt compressed edge. If compression is achieved Top to bottom of FB750 Intubatt, left/right is not required to be compressed and vice versa (the non-compressed seal should be fully abutted and bonded). All joints are to be bonded using FS712 Intucoat to full width of the FB750 Intubatt or FS702 Intumastic applied as a 10mm bead along the full-length joint centre line. FS702 Intumastic should be used to point all service and substrate interfaces, to a minimum of a 6mm bead. Apertures for penetrating services are to be tightly fitted and sealed. Imperfections should be filled with FS702 Intumastic to the full depth of the FB750 Intubatt. Service openings should be cut no more than 15mm away from non-combustible services, and/or, openings should be cut to suit the requirements of any additional required Nullifire product, if the service type is combustible or insulated CS or LS. (Imperfections in cut on a compressed edge may not exceed 40% of the area available to receive compression)	
The results below are also applicable when using multiple layers of FB750 Intubatt, including 1 layer (or more) of surface mounted FB750 Intubatt.	
	

Form-ULID-006104 (DCS:27-CP-F0855) 5.0



Appendix UL-EU CERTIFICATE

Certificate No. UL-EU-01058-CPR
 Page 96/144
 Date of Issue 2017-10-27

Service			CS Pipe Insulation (Continuous Sustained)		Pipe Diameter	Pipe Wall Thickness#	Pipe End Configuration		Integrity	Integrity & Insulation	Rigid Wall Thickness (mm)	Flexible Wall Thickness (mm)	Additional Requirements
Cast Iron	Steel	Copper	Material	Thickness (mm)	(mm)	(mm)	C/C	C/U	E (mins)	EI (mins)	≥ 100	≥ 100	
✓	✓	✓	PIR / Phenolic	50	≤ 28	≥ 1	✓	✓	60	60	✓	✓	2 layers of FP302 Intustrap (central to the seal), sealed on both sides of FB750 Intubatt with FS702 Intumastic
✓	✓	✓	PIR / Phenolic	20	≤ 28	≥ 1	✓	✓	60	60	✓	✓	20mm annulus of FS709 HP Intumescent Sealant, 50mm depth
✓	✓	✓	PIR / Phenolic	50	≤ 42	≥ 1	✓	✓	60	30	✓	✓	2 layers of FP302 Intustrap (central to the seal), sealed on both sides of FB750 Intubatt with FS702 Intumastic
✓	✓	✓	PIR / Phenolic	20	≤ 48	≥ 1	✓	✓	60	30	✓	✓	2 layers of FP302 Intustrap (central to the seal), sealed on both sides of FB750 Intubatt with FS702 Intumastic
✓	✓	✓	PIR / Phenolic	20	≤ 48	≥ 1	✓	✓	60	15	✓	✓	20mm annulus of FS709 HP Intumescent Sealant, 50mm depth

#Up to maximum 14.2 mm



Appendix UL-EU CERTIFICATE

Certificate No. UL-EU-01058-CPR
Page 97/144
Date of Issue 2017-10-27

Non-Combustible Pipes Insulated LS – Double Batt Pattress

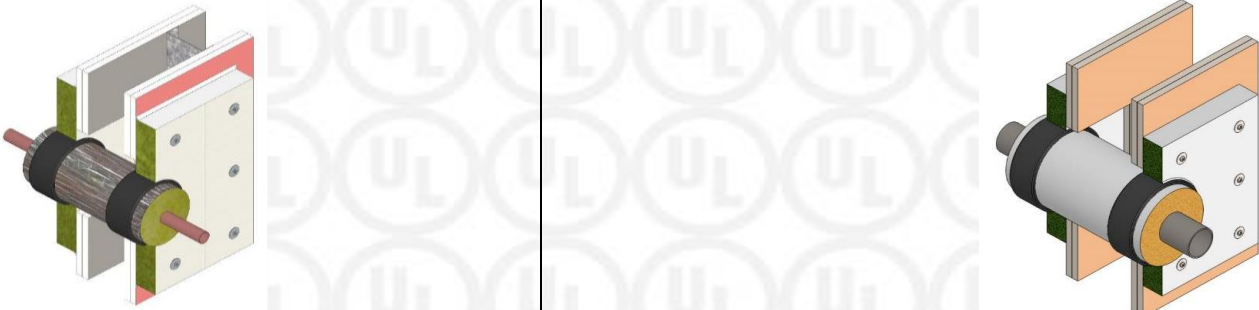
Non-Combustible Pipes Insulated with Local Sustained Insulation passing through Flexible and Rigid Walls as identified below, protected by double pattress (surface mounted) FB750 Intubatt seal, sealed with FS702 Intumastic or FS712 Intucoat.
Wall Details: Flexible or Rigid Walls including Concrete, Brick / Blockwork & AAC, of minimum thickness as identified below, and with performance classified to EN 13501-2. Flexible Walls constructed from steel or timber faced studs with a minimum of 2 x 12.5mm EN 520 type F boards on each side of studs.
Maximum Opening size: 200mm by 200mm. Multiple openings must be separated by a minimum of 200mm for fire resistance requirements. Check separation requirements with the system owner of the supporting construction.
Installation Instructions: Boards surface mounted (pattress fit) on both sides of the wall with a minimum 75mm overlap around the opening. (Overlap on the lowest edge can be reduced to 30mm in the event of an obstruction preventing the 75mm overlap). The overlap should be bonded with a 10mm bead of FS702 Intumastic placed 20-60mm from the board edges, and additionally mechanically restrained using 75mm steel screws with a 25mm washer at maximum 300mm centres, 10-65mm from the board perimeter and no more than 50mm from a board joint. A low torque setting should be used to ensure that the embedment of fixing into the board does not exceed 15mm. The fixings may be left exposed or covered using FS702 Intumastic. The FB750 Intubatt should be installed in as few cut pieces as possible. All joints are to be bonded using FS712 Intucoat to full width of the FB750 Intubatt or FS702 Intumastic applied as a 10mm bead along the full-length joint centre line. FS702 Intumastic should be used to point all service and substrate interfaces, to a minimum of a 6mm bead. Apertures for penetrating services are to be tightly fitted and sealed. Imperfections should be filled with FS702 Intumastic to the full depth of the FB750 Intubatt. Service openings should be cut no more than 15mm away from non-combustible services, and/or, openings should be cut to suit the requirements of any additional required Nullifire product, if the service type is combustible or insulated CS or LS. External sides of the Board may be required to be coated for aesthetic reasons or to prevent fibre migration. (In situations where the required overlap cannot be achieved due to a perpendicular fire resisting wall / soffit, it is possible to reduce the overlap, down to as low as 0mm, provided the board edge is bonded to the adjoining compartment using a 10mm bead of FS702 Intumastic, and subsequently pointed to all mated edges)
The results below are also applicable when using multiple layers of surface mounted FB750 Intubatt. For multiple layers of FB750 Intubatt so a single (or both) face, identically sized boards should be used, ideally with staggered joints where possible. Closing devices should be located in or on the outmost board. Board to board abutment should be bonded with 10mm bead of FS702 Intumastic and mechanically restrained using a 75mm spiral screw to the first and secured layer. Spiral fixings should be at max 200mm centres and no more than 50mm from any joint.

Form-ULID-006104 (DCS:27-CP-F0855) 5.0



Appendix UL-EU CERTIFICATE

Certificate No. UL-EU-01058-CPR
 Page 98/144
 Date of Issue 2017-10-27

Service				LS Insulation (Local Sustained)			Pipe Diameter	Pipe Wall Thickness#	Pipe End Configuration		Integrity	Integrity & Insulation	Rigid Wall Thickness (mm)	Flexible Wall Thickness (mm)	Additional Requirements (Both Sides)
Cast Iron	Steel	Copper	-	Material	Thickness (mm)	Length on both sides (mm)	(mm)	(mm)	C/C	C/U	E (mins)	EI (mins)	≥ 100	≥ 100	
✓	✓	✓		PIR / Phenolic	20	≥ 200	≤ 14	≥ 1.2	✓	✓	120	120	✓	✓	2 layers of FP302 Intustrap, sealed within FB750 Intubatt with FS702 Intumastic
✓	✓	✓	(*)	PIR / Phenolic	50	≥ 200	≤ 28	≥ 1.2	✓	✓	120	120	✓	✓	20mm annulus of FS709 HP Intumescent Sealant, 50mm depth
✓	✓	✓	(*)	PIR / Phenolic	20	≥ 200	≤ 14	≥ 1.2	✓	✓	120	120	✓	✓	20mm annulus of FS709 HP Intumescent Sealant, 50mm depth
✓	✓	✓		PIR / Phenolic	50	≥ 200	≤ 28	≥ 1.2	✓	✓	120	90	✓	✓	2 layers of FP302 Intustrap, sealed within FB750 Intubatt with FS702 Intumastic
✓	✓	✓		PIR / Phenolic	20	≥ 200	≤ 28	≥ 1.2	✓	✓	120	90	✓	✓	2 layers of FP302 Intustrap, sealed within FB750 Intubatt with FS702 Intumastic
✓	✓	✓		PIR / Phenolic	20	≥ 200	≤ 28	≥ 1.2	✓	✓	120	90	✓	✓	20mm annulus of FS709 HP Intumescent Sealant, 50mm depth
✓	✓	✓	(*)	PIR / Phenolic	20	≥ 200	≤ 48	≥ 1.2	✓	✓	120	90	✓	✓	20mm annulus of FS709 HP Intumescent Sealant, 50mm depth
✓	✓	✓		PIR / Phenolic	50	≥ 200	≤ 42	≥ 1.2	✓	✓	120	30	✓	✓	2 layers of FP302 Intustrap, sealed within FB750 Intubatt with FS702 Intumastic



Appendix UL-EU CERTIFICATE

Certificate No. UL-EU-01058-CPR
 Page 99/144
 Date of Issue 2017-10-27

Service				LS Insulation (Local Sustained)			Pipe Diameter	Pipe Wall Thickness#	Pipe End Configuration		Integrity	Integrity & Insulation	Rigid Wall Thickness (mm)	Flexible Wall Thickness (mm)	Additional Requirements (Both Sides)
Cast Iron	Steel	Copper	-	Material	Thickness (mm)	Length on both sides (mm)	(mm)	(mm)	C/C	C/U	E (mins)	EI (mins)	≥ 100	≥ 100	
✓	✓	✓		PIR / Phenolic	20	≥ 200	≤ 42	≥ 1.2	✓	✓	120	30	✓	✓	2 layers of FP302 Intustrap, sealed within FB750 Intubatt with FS702 Intumastic
✓	✓	✓	(*)	PIR / Phenolic	50	≥ 200	≤ 42	≥ 1.2	✓	✓	60	30	✓	✓	20mm annulus of FS709 HP Intumescent Sealant, 50mm depth

(*) Includes horizontal pipes from 90° to 45° to supporting construction
 #Up to maximum 14.2 mm



Appendix UL-EU CERTIFICATE

Certificate No. UL-EU-01058-CPR
Page 100/144
Date of Issue 2017-10-27

Non-Combustible Pipes Insulated LS – Double Batt Compression

Non-Combustible Pipes Insulated with Local Sustained Insulation passing through Flexible and Rigid Walls as identified below, protected by double compressed FB750 Intubatt seal, sealed with FS702 Intumastic or FS712 Intucoat.
Wall Details: Flexible or Rigid Walls including Concrete, Brick / Blockwork & AAC, of minimum thickness as identified below, and with performance classified to EN 13501-2. Flexible Walls constructed from steel or timber faced studs with a minimum of 2 x 12.5mm EN 520 type F boards on each side of studs.
Maximum Opening size: 400mm by 400mm. In Flexible Walls openings should be created using a steel frame. Multiple openings must be separated by a minimum of 200mm for fire resistance requirements. Check separation requirements with the system owner of the supporting construction.
Installation Instructions: Double Layer board, compressed and bonded into the aperture outer face flush with the face of the supporting construction. FB750 Intubatt should be installed in as few cut pieces as possible and tightly compressed to two opposite sides. This is achieved by the addition of 2mm to the required cut dimension. Compression may be applied - FB750 Intubatt to FB750 Intubatt, FB750 Intubatt to non-combustible service, or FB750 Intubatt to Substrate. Compression must be achieved over a minimum 60% of the FB750 Intubatt compressed edge. If compression is achieved Top to bottom of FB750 Intubatt, left/right is not required to be compressed and vice versa (the non-compressed seal should be fully abutted and bonded). All joints are to be bonded using FS712 Intucoat to full width of the FB750 Intubatt or FS702 Intumastic applied as a 10mm bead along the full-length joint centre line. FS702 Intumastic should be used to point all service and substrate interfaces, to a minimum of a 6mm bead. Apertures for penetrating services are to be tightly fitted and sealed. Imperfections should be filled with FS702 Intumastic to the full depth of the FB750 Intubatt. Service openings should be cut no more than 15mm away from non-combustible services, and/or, openings should be cut to suit the requirements of any additional required Nullifire product, if the service type is combustible or insulated CS or LS. (Imperfections in cut on a compressed edge may not exceed 40% of the area available to receive compression)
The results below are also applicable when using multiple layers of FB750 Intubatt, including 1 layer (or more) surface mounted on both sides of the wall.

Form-ULID-006104 (DCS:27-CP-F0855) 5.0



Appendix UL-EU CERTIFICATE

Certificate No. UL-EU-01058-CPR
 Page 101/144
 Date of Issue 2017-10-27

Service				LS Insulation (Local Sustained)			Pipe Diameter	Pipe Wall Thickness#	Pipe End Configuration		Integrity	Integrity & Insulation	Rigid Wall Thickness (mm)	Flexible Wall Thickness (mm)	Additional Requirements (Both Sides)
Cast Iron	Steel	Copper	-	Material	Thickness (mm)	Length on both sides (mm)	(mm)	(mm)	C/C	C/U	E (mins)	EI (mins)	≥ 100	≥ 100	
✓	✓	✓		PIR / Phenolic	20	≥ 200	≤ 14	≥ 1	✓	✓	120	120	✓	✓	2 layers of FP302 Intustrap, sealed within FB750 Intubatt with FS702 Intumastic
✓	✓	✓	(*)	PIR / Phenolic	50	≥ 200	≤ 28	≥ 1	✓	✓	120	120	✓	✓	20mm annulus of FS709 HP Intumescent Sealant, 50mm depth
✓	✓	✓	(*)	PIR / Phenolic	20	≥ 200	≤ 14	≥ 1	✓	✓	120	120	✓	✓	20mm annulus of FS709 HP Intumescent Sealant, 50mm depth
✓	✓	✓		PIR / Phenolic	50	≥ 200	≤ 28	≥ 1	✓	✓	120	90	✓	✓	2 layers of FP302 Intustrap, sealed within FB750 Intubatt with FS702 Intumastic
✓	✓	✓		PIR / Phenolic	20	≥ 200	≤ 28	≥ 1	✓	✓	120	90	✓	✓	2 layers of FP302 Intustrap, sealed within FB750 Intubatt with FS702 Intumastic
✓	✓	✓	(*)	PIR / Phenolic	20	≥ 200	≤ 48	≥ 1	✓	✓	120	90	✓	✓	20mm annulus of FS709 HP Intumescent Sealant, 50mm depth
✓	✓	✓		PIR / Phenolic	50	≥ 200	≤ 42	≥ 1	✓	✓	120	30	✓	✓	2 layers of FP302 Intustrap, sealed within FB750 Intubatt with FS702 Intumastic
✓	✓	✓	(*)	PIR / Phenolic	50	≥ 200	≤ 42	≥ 1	✓	✓	60	30	✓	✓	20mm annulus of FS709 HP Intumescent Sealant, 50mm depth

(*) Includes horizontal pipes from 90° to 45° to supporting construction
 #Up to maximum 14.2 mm



Appendix UL-EU CERTIFICATE

Certificate No. UL-EU-01058-CPR
Page 102/144
Date of Issue 2017-10-27

Non-Combustible Pipes Insulated LS – Single Batt Compression (Asymmetric)

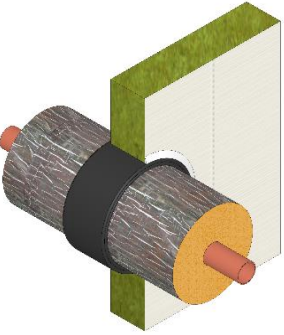
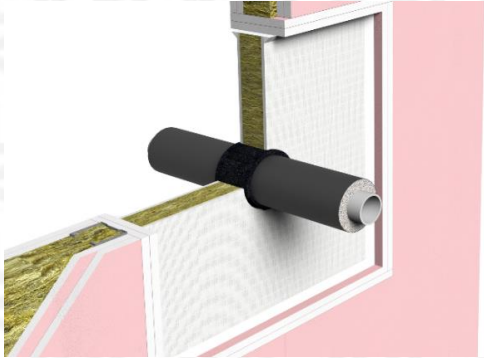
Non-Combustible Pipes Insulated with Local Sustained Insulation passing through Flexible and Rigid Walls as identified below, protected by single compressed asymmetric FB750 Intubatt seal, sealed with FS702 Intumastic or FS712 Intucoat.	
Wall Details: Flexible or Rigid Walls including Concrete, Brick / Blockwork & AAC, of minimum thickness as identified below, and with performance classified to EN 13501-2. Flexible Walls constructed from steel or timber faced studs with a minimum of 2 x 12.5mm EN 520 type F boards on each side of studs.	
Maximum Opening size: 400mm by 400mm. In Flexible Walls openings should be created using a steel frame with a plasterboard lining. Multiple openings must be separated by a minimum of 200mm for fire resistance requirements. Check separation requirements with the system owner of the supporting construction.	
Installation Instructions: Single Layer board, compressed and bonded into the aperture on the opposite side of the wall to the fire. FB750 Intubatt should be installed in as few cut pieces as possible and tightly compressed to two opposite sides. This is achieved by the addition of 2mm to the required cut dimension. Compression may be applied - FB750 Intubatt to FB750 Intubatt, FB750 Intubatt to non-combustible service, or FB750 Intubatt to Substrate. Compression must be achieved over a minimum 60% of the FB750 Intubatt compressed edge. If compression is achieved Top to bottom of FB750 Intubatt, left/right is not required to be compressed and vice versa (the non-compressed seal should be fully abutted and bonded). All joints are to be bonded using FS712 Intucoat to full width of the FB750 Intubatt or FS702 Intumastic applied as a 10mm bead along the full-length joint centre line. FS702 Intumastic should be used to point all service and substrate interfaces, to a minimum of a 6mm bead. Apertures for penetrating services are to be tightly fitted and sealed. Imperfections should be filled with FS702 Intumastic to the full depth of the FB750 Intubatt. Service openings should be cut no more than 15mm away from non-combustible services, and/or, openings should be cut to suit the requirements of any additional required Nullifire product, if the service type is combustible or insulated CS or LS. (Imperfections in cut on a compressed edge may not exceed 40% of the area available to receive compression)	
The results below are also applicable when using multiple layers of FB750 Intubatt, including 1 layer (or more) of surface mounted FB750 Intubatt.	
	

Form-ULID-006104 (DCS:27-CP-F0855) 5.0



Appendix UL-EU CERTIFICATE

Certificate No. UL-EU-01058-CPR
 Page 103/144
 Date of Issue 2017-10-27

Service			LS Insulation (Local Sustained)			Pipe Diameter	Pipe Wall Thickness#	Pipe End Configuration		Integrity	Integrity & Insulation	Rigid Wall Thickness (mm)	Flexible Wall Thickness (mm)	Additional Requirements
Cast Iron	Steel	Copper	Material	Thickness (mm)	Length on both sides (mm)	(mm)	(mm)	C/C	C/U	E (mins)	EI (mins)	≥ 100	≥ 100	
✓	✓	✓	PIR / Phenolic	50	≥ 200	≤ 28	≥ 1	✓	✓	60	60	✓	✓	2 layers of FP302 Intustrap (central to the seal), sealed on both sides of FB750 Intubatt with FS702 Intumastic
✓	✓	✓	PIR / Phenolic	20	≥ 200	≤ 28	≥ 1	✓	✓	60	60	✓	✓	20mm annulus of FS709 HP Intumescent Sealant, 50mm depth
✓	✓	✓	PIR / Phenolic	50	≥ 200	≤ 42	≥ 1	✓	✓	60	30	✓	✓	2 layers of FP302 Intustrap (central to the seal), sealed on both sides of FB750 Intubatt with FS702 Intumastic
✓	✓	✓	PIR / Phenolic	20	≥ 220	≤ 48	≥ 1	✓	✓	60	30	✓	✓	2 layers of FP302 Intustrap (central to the seal), sealed on both sides of FB750 Intubatt with FS702 Intumastic
✓	✓	✓	PIR / Phenolic	20	≥ 200	≤ 48	≥ 1	✓	✓	60	15	✓	✓	20mm annulus of FS709 HP Intumescent Sealant, 50mm depth

#Up to maximum 14.2 mm



Appendix UL-EU CERTIFICATE

Certificate No. UL-EU-01058-CPR
Page 104/144
Date of Issue 2017-10-27

Blank Seals – Double Batt Pattress

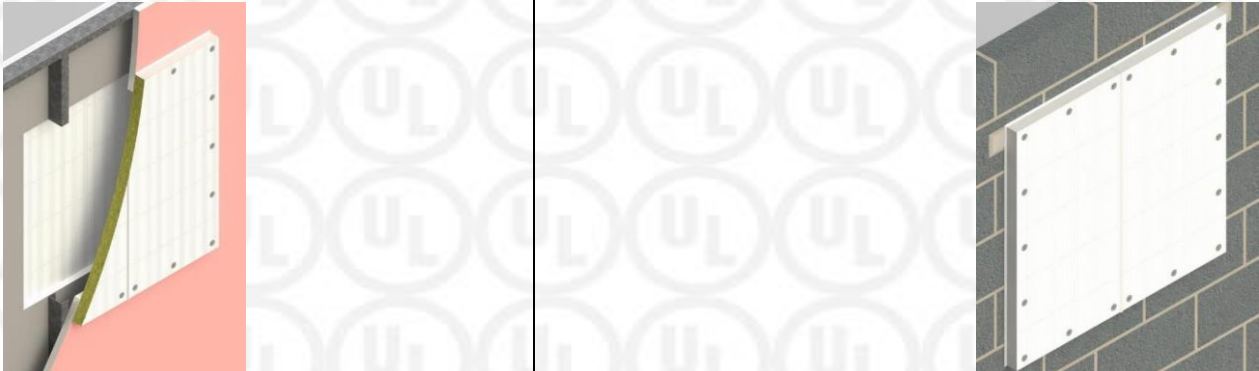
Blank Seals installed in Flexible Walls or Rigid Walls as Identified below, protected by double pattress (surface mounted) FB750 Intubatt seal, sealed with FS702 Intumastic or FS712 Intucoat.
Wall Details: Flexible or Rigid Walls including Concrete, Brick / Blockwork & AAC, of minimum thickness as identified below, and with performance classified to EN 13501-2. Flexible Walls constructed from steel or timber faced studs with a minimum of 2 x 12.5mm EN 520 type F boards on each side of studs.
Maximum Opening size: See below. Multiple openings must be separated by a minimum of 200mm for fire resistance requirements. Check separation requirements with the system owner of the supporting construction.
Installation Instructions: Boards surface mounted (pattress fit) on both sides of the wall with a minimum 75mm overlap around the opening. (Overlap on the lowest edge can be reduced to 30mm in the event of an obstruction preventing the 75mm overlap). The overlap should be bonded with a 10mm bead of FS702 Intumastic placed 20-60mm from the board edges, and additionally mechanically restrained using 75mm steel screws with a 25mm washer at maximum 300mm centres, 10-65mm from the board perimeter and no more than 50mm from a board joint. A low torque setting should be used to ensure that the embedment of fixing into the board does not exceed 15mm. The fixings may be left exposed or covered using FS702 Intumastic. The FB750 Intubatt should be installed in as few cut pieces as possible. All joints are to be bonded using FS712 Intucoat to full width of the FB750 Intubatt or FS702 Intumastic applied as a 10mm bead along the full-length joint centre line. FS702 Intumastic should be used to point all substrate interfaces, to a minimum of a 6mm bead. Imperfections should be filled with FS702 Intumastic to the full depth of the FB750 Intubatt. External sides of the Board may be required to be coated for aesthetic reasons or to prevent fibre migration. (In situations where the required overlap cannot be achieved due to a perpendicular fire resisting wall / soffit, it is possible to reduce the overlap, down to as low as 0mm, provided the board edge is bonded to the adjoining compartment using a 10mm bead of FS702 Intumastic, and subsequently pointed to all mated edges)
The results below are also applicable when using multiple layers of surface mounted FB750 Intubatt. For multiple layers of FB750 Intubatt so a single (or both) face, identically sized boards should be used, ideally with staggered joints where possible. Closing devices should be located in or on the outmost board. Board to board abutment should be bonded with 10mm bead of FS702 Intumastic and mechanically restrained using a 75mm spiral screw to the first and secured layer. Spiral fixings should be at max 200mm centres and no more than 50mm from any joint.

Form-ULID-006104 (DCS:27-CP-F0855) 5.0



Appendix UL-EU CERTIFICATE

Certificate No. UL-EU-01058-CPR
 Page 105/144
 Date of Issue 2017-10-27

Opening size (mm)	Integrity	Integrity & Insulation	Rigid Wall Thickness (mm)		Flexible Wall Thickness (mm)	
	E (mins)	EI (mins)	≥ 130	≥ 100	≥ 130	≥ 100
≤ 1500 x 1500	240	240	✓	✓		
≤ 1500 x 450	120	120	✓	✓	✓	✓
≤ 1140 x 480	120	120	✓		✓	



Appendix UL-EU CERTIFICATE

Certificate No. UL-EU-01058-CPR
Page 106/144
Date of Issue 2017-10-27

Blank Seals – Double Batt Compression

Blank Seals installed in Flexible Walls or Rigid Walls as Identified below, protected by double compressed FB750 Intubatt seal, sealed with FS702 Intumastic or FS712 Intucoat.

Wall Details: Flexible or Rigid Walls including Concrete, Brick / Blockwork & AAC, of minimum thickness as identified below, and with performance classified to EN 13501-2.
Flexible Walls constructed from steel or timber faced studs with a minimum of 2 x 12.5mm EN 520 type F boards on each side of studs.

Maximum Opening size: See below. In Flexible Walls openings should be created using a steel frame. Multiple openings must be separated by a minimum of 200mm for fire resistance requirements. Check separation requirements with the system owner of the supporting construction.

Installation Instructions: Double Layer board, compressed and bonded into the aperture outer face flush with the face of the supporting construction. FB750 Intubatt should be installed in as few cut pieces as possible and tightly compressed to two opposite sides. This is achieved by the addition of 2mm to the required cut dimension. Compression may be applied - FB750 Intubatt to FB750 Intubatt, or FB750 Intubatt to Substrate. Compression must be achieved over a minimum 60% of the FB750 Intubatt compressed edge. If compression is achieved Top to bottom of FB750 Intubatt, left/right is not required to be compressed and vice versa (the non-compressed seal should be fully abutted and bonded). All joints are to be bonded using FS712 Intucoat to full width of the FB750 Intubatt or FS702 Intumastic applied as a 10mm bead along the full-length joint centre line. FS702 Intumastic should be used to point all substrate interfaces, to a minimum of a 6mm bead. Imperfections should be filled with FS702 Intumastic to the full depth of the FB750 Intubatt. (Imperfections in cut on a compressed edge may not exceed 40% of the area available to receive compression)

The results below are also applicable when using multiple layers of FB750 Intubatt, including 1 layer (or more) surface mounted on both sides of the wall.

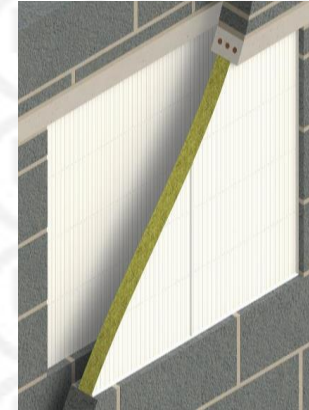
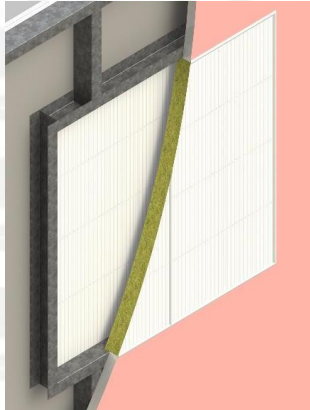

Form-ULID-006104 (DCS:27-CP-F0855) 5.0



Appendix UL-EU CERTIFICATE

Certificate No. UL-EU-01058-CPR
 Page 107/144
 Date of Issue 2017-10-27

Opening Size (mm)	Integrity	Integrity & Insulation	Rigid Wall Thickness (mm)		Flexible Wall Thickness (mm)	
	E (mins)	EI (mins)	≥ 130	≥ 100	≥ 130	≥ 100
≤ 1500 x 1500	240	240	✓	✓		
≤ 1500 x 450	120	120	✓	✓	✓	✓
≤ 1140 x 480	120	120	✓		✓	



Appendix UL-EU CERTIFICATE

Certificate No. UL-EU-01058-CPR
Page 108/144
Date of Issue 2017-10-27

Blank Seals – Single Batt Pattress

Blank Seals installed in Rigid Walls as Identified below, protected by single FB750 Intubatt seal, pattress fitted to one side, sealed with FS702 Intumastic or FS712 Intucoat.

Wall Details: Rigid Walls including Concrete, Brick / Blockwork & AAC, of minimum thickness as identified below, and with performance classified to EN 13501-2.

Maximum Opening size: See below. Multiple openings must be separated by a minimum of 200mm for fire resistance requirements. Check separation requirements with the system owner of the supporting construction.

Installation Instructions: Single Layer board, surface mounted (pattress fit) with 75mm overlap beyond the aperture on the opposite side of the wall to the fire. FB750 Intubatt should be installed in as few cut pieces as possible. All joints are to be bonded using FS712 Intucoat to full width of the FB750 Intubatt or FS702 Intumastic applied as a 10mm bead along the full-length joint centre line. FS702 Intumastic should be used to point all substrate interfaces, to a minimum of a 6mm bead. Imperfections should be filled with FS702 Intumastic to the full depth of the FB750 Intubatt.

The results below are also applicable when using multiple layers of surface mounted FB750 Intubatt.

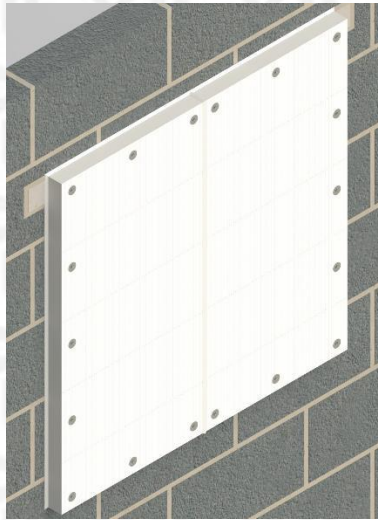

Form-ULID-006104 (DCS:27-CP-F0855) 5.0



Appendix UL-EU CERTIFICATE

Certificate No. UL-EU-01058-CPR
Page 109/144
Date of Issue 2017-10-27

Opening Size	Integrity	Integrity & Insulation	Rigid Wall Thickness (mm)
	E (mins)	EI (mins)	≥ 130
≤ 400 x 400	120	60	✓



Appendix UL-EU CERTIFICATE

Certificate No. UL-EU-01058-CPR
Page 110/144
Date of Issue 2017-10-27

Blank Seals – Single Batt Compression

Blank Seals installed in Flexible Walls or Rigid Walls as Identified below, protected by single compressed FB750 Intubatt seal, sealed with FS702 Intumastic or FS712 Intucoat.
Wall Details: Flexible or Rigid Walls including Concrete, Brick / Blockwork & AAC, of minimum thickness as identified below, and with performance classified to EN 13501-2. Flexible Walls constructed from steel or timber faced studs with a minimum of 2 x 12.5mm EN 520 type F boards on each side of studs.
Maximum Opening size: See below. In Flexible Walls openings should be created using a steel frame with a plasterboard lining. Multiple openings must be separated by a minimum of 200mm for fire resistance requirements. Check separation requirements with the system owner of the supporting construction.
Installation Instructions: Single Layer board, compressed and bonded into the aperture at mid depth of the wall. FB750 Intubatt should be installed in as few cut pieces as possible and tightly compressed to two opposite sides. This is achieved by the addition of 2mm to the required cut dimension. Compression may be applied - FB750 Intubatt to FB750 Intubatt or FB750 Intubatt to Substrate. Compression must be achieved over a minimum 60% of the FB750 Intubatt compressed edge. If compression is achieved Top to bottom of FB750 Intubatt, left/right is not required to be compressed and vice versa (the non-compressed seal should be fully abutted and bonded). All joints are to be bonded using FS712 Intucoat to full width of the FB750 Intubatt or FS702 Intumastic applied as a 10mm bead along the full-length joint centre line. FS702 Intumastic should be used to point all service and substrate interfaces, to a minimum of a 6mm bead. Imperfections should be filled with FS702 Intumastic to the full depth of the FB750 Intubatt. (Imperfections in cut on a compressed edge may not exceed 40% of the area available to receive compression)
The results below are also applicable when using multiple layers of FB750 Intubatt, including 1 layer (or more) surface mounted on both sides of the wall.

Form-ULID-006104 (DCS:27-CP-F0855) 5.0



Appendix UL-EU CERTIFICATE

Certificate No. UL-EU-01058-CPR
 Page 111/144
 Date of Issue 2017-10-27

Opening Size (mm)	Integrity	Integrity & Insulation	Rigid Wall Thickness (mm)		Flexible Wall Thickness (mm)	
	E (mins)	EI (mins)	≥ 130	≥ 100	≥ 130	≥ 100
≤ 300 x 300	120	120	✓		✓	
≤ 1800 x 1200	120	30	✓	✓	✓	✓

Form-ULID-006104 (DCS:27-CP-F0855) 5.0



Appendix UL-EU CERTIFICATE

Certificate No. UL-EU-01058-CPR
Page 112/144
Date of Issue 2017-10-27

Floors

Cables and Cable Carriers – Double Batt Pattress

Cables, Metal Cable Trays, Trunking, Baskets and Ladders passing through Rigid Floors as identified below, protected by double pattress (surface mounted) FB750 Intubatt seal, sealed with FS702 Intumastic or FS712 Intucoat.
Floor Details: Rigid Floors of minimum thickness as identified below, and with performance classified to EN 13501-2.
Maximum Opening size: 1100mm by 450mm. Multiple apertures must be separated by a minimum of 200mm for fire resistance requirements. Check separation requirements with the system owner of the supporting construction.
Installation Instructions: Double layer board, surface mounted (pattress fit) on under side of the floor with a minimum 75mm overlap around the opening. The overlap should be bonded with a 10mm bead of FS702 Intumastic placed 20-60mm from the board edges, and additionally mechanically restrained using 75mm steel screws with a 25mm washer at maximum 300mm centres, 10-65mm from the board perimeter and no more than 50mm from a board joint. A low torque setting should be used to ensure that the embedment of fixing into the board does not exceed 15mm. The fixings may be left exposed or covered using FS702 Intumastic. The FB750 Intubatt should be installed in as few cut pieces as possible. All joints are to be bonded using FS712 Intucoat to full width of the FB750 Intubatt or FS702 Intumastic applied as a 10mm bead along the full-length joint centre line. FS702 Intumastic should be used to point all service and substrate interfaces, to a minimum of a 6mm bead. Apertures for penetrating services are to be tightly fitted and sealed. Imperfections should be filled with FS702 Intumastic to the full depth of the FB750 Intubatt. Service openings should be cut no more than 15mm away from non-combustible services, and/or, openings should be cut to suit the requirements of any additional required Nullifire product, if the service type is combustible or insulated CS or LS. External sides of the Board may be required to be coated for aesthetic reasons or to prevent fibre migration.
The results below are also applicable when using multiple layers of surface mounted FB750 Intubatt to the underside of the floor, or double / multiple layers compressed and bonded within the floor, or double / multiple layers to the upper face of the floor.

Form-ULID-006104 (DCS:27-CP-F0855) 5.0



Appendix UL-EU CERTIFICATE

Certificate No. UL-EU-01058-CPR
 Page 113/144
 Date of Issue 2017-10-27

Service	Integrity	Integrity & Insulation	Rigid Floor Thickness (mm)	Additional Requirements
	E (mins)	EI (mins)	≥ 150	
Bundle of ≤ 42mm diameter, comprising ≤ 8 Twin & earth cables, each ≤ 17mm diameter within a ≤ 55mm x 3.2mm HDPE conduit	240	240	✓	1 layer of FP302 Intustrap, central to the seal, sealed within FB750 Intubatt with FS702 Intumastic
Bundle of ≤ 10 Ethernet Cat 5 cables, each ≤ 6mm diameter	180	120	✓	-
Bundle of ≤ 5 Fibre optic cables, each ≤ 8mm diameter	180	120	✓	-
Bundle of ≤ 3 Fire alarm cables, each ≤ 13mm diameter	180	120	✓	-
Bundle of ≤ 6 lighting cables, each ≤ 10mm diameter	180	120	✓	-
Bundle of ≤ 25 Ethernet Cat 5 cable, each ≤ 6mm diameter	60	60	✓	-
Bundle of ≤ 8 Twin & earth cables, each ≤ 17mm diameter	60	60	✓	-

Cable diameters can be increased up to 25%, and cable bundle diameters can be increased up to 10%



Appendix UL-EU CERTIFICATE

Certificate No. UL-EU-01058-CPR
Page 114/144
Date of Issue 2017-10-27

Cables and Cable Carriers – Double Batt Compression

Cables, Metal Cable Trays, Trunking, Baskets and Ladders passing through Rigid Floors as identified below, protected by double compressed FB750 Intubatt seal, sealed with FS702 Intumastic or FS712 Intucoat.
Floor Details: Rigid Floors of minimum thickness as identified below, and with performance classified to EN 13501-2.
Maximum Opening size: 1100mm by 450mm. Multiple apertures must be separated by a minimum of 200mm for fire resistance requirements. Check separation requirements with the system owner of the supporting construction.
Installation Instructions: Double Layer board, compressed and bonded into the aperture within the floor. FB750 Intubatt should be installed in as few cut pieces as possible and tightly compressed to two opposite sides. This is achieved by the addition of 2mm to the required cut dimension. Compression may be applied - FB750 Intubatt to FB750 Intubatt, FB750 Intubatt to non-combustible service, or FB750 Intubatt to Substrate. Compression must be achieved over a minimum 60% of the FB750 Intubatt Compressed edge. If compression is achieved between two opposite sides of FB750 Intubatt, the perpendicular sides are not required to be compressed (the non-compressed seal should be fully abutted and bonded). All joints are to be bonded using FS712 Intucoat to full width of the FB750 Intubatt or FS702 Intumastic applied as a 10mm bead along the full-length joint centre line. FS702 Intumastic should be used to point all service and substrate interfaces, to a minimum of a 6mm bead. Apertures for penetrating services are to be tightly fitted and sealed. Imperfections should be filled with FS702 Intumastic to the full depth of the FB750 Intubatt. Service openings should be cut no more than 15mm away from non-combustible services, and/or, openings should be cut to suit the requirements of any additional required Nullifire product, if the service type is combustible or insulated CS or LS. (Imperfections in cut on a compressed edge may not exceed 40% of the area available to receive compression)
The results below are also applicable when using multiple layers of FB750 Intubatt compressed in the opening, including double/multiple layers of surface mounted FB750 Intubatt to the upper face.

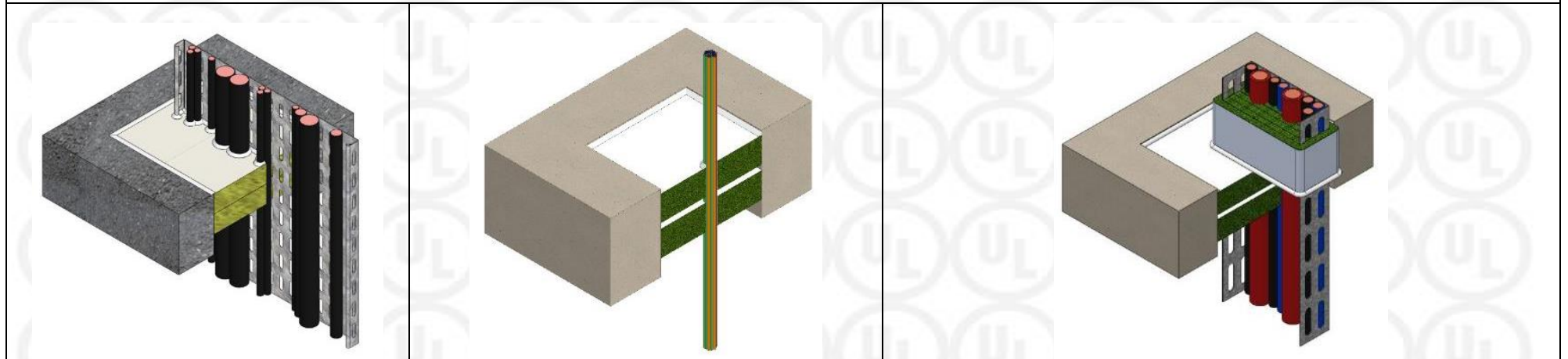

Form-ULID-006104 (DCS:27-CP-F0855) 5.0



Appendix UL-EU CERTIFICATE

Certificate No. UL-EU-01058-CPR
 Page 115/144
 Date of Issue 2017-10-27

Service		Integrity	Integrity & Insulation	Rigid Floor Thickness (mm)	Additional Requirements (Top Side Only)
		E (mins)	EI (mins)	≥ 150	
Metal Cable Trays, Trunking, Baskets and Ladder ≤ 300mm width & minimum 1.3mm thickness	B	120	120	✓	200mm extension of 1 layer of FI025 Intuflex, sealed to FB750 Intubatt with FS702 Intumastic
Metal Cable Trays, Trunking, Baskets and Ladder ≤ 500mm width & minimum 1mm thickness	C	120	60	✓	-
Bundle of ≤ 10 A2 cables, each ≤ 12mm diameter	B	120	120	✓	200mm extension of 1 layer of FI025 Intuflex, sealed to FB750 Intubatt with FS702 Intumastic
Bundle of ≤ 10 A3 cables, each ≤ 12mm diameter	B	120	120	✓	200mm extension of 1 layer of FI025 Intuflex, sealed to FB750 Intubatt with FS702 Intumastic
≤ 2 type B cables, each ≤ 19mm diameter	B	120	120	✓	200mm extension of 1 layer of FI025 Intuflex, sealed to FB750 Intubatt with FS702 Intumastic
1 type C1 cable ≤ 41mm diameter	B	120	120	✓	200mm extension of 1 layer of FI025 Intuflex, sealed to FB750 Intubatt with FS702 Intumastic
1 type C2 cable ≤ 50mm diameter	B	120	120	✓	200mm extension of 1 layer of FI025 Intuflex, sealed to FB750 Intubatt with FS702 Intumastic
1 type C3 cable ≤ 37mm diameter	B	120	120	✓	200mm extension of 1 layer of FI025 Intuflex, sealed to FB750 Intubatt with FS702 Intumastic
1 type C2 cable ≤ 50mm diameter	C	120	90	✓	-
≤ 2 type B cables, each ≤ 19mm diameter	C	120	60	✓	-
1 type C1 cable ≤ 41mm diameter	C	120	60	✓	-
1 type C3 cable ≤ 37mm diameter	C	120	60	✓	-

Form-ULID-006104 (DCS:27-CP-F0855) 5.0



Appendix UL-EU CERTIFICATE

Certificate No. UL-EU-01058-CPR
 Page 116/144
 Date of Issue 2017-10-27

Service		Integrity	Integrity & Insulation	Rigid Floor Thickness (mm)	Additional Requirements (Top Side Only)
		E (mins)	EI (mins)	≥ 150	
1 type G1 cable ≤ 15mm diameter	C	120	30	✓	-
1 type G2 cable ≤ 20mm diameter	C	120	30	✓	-

Cable diameters can be increased up to 25%, and cable bundle diameters can be increased up to 10%
 A: Batts fitted together, flush to lower surface. Data covers applications mid-depth or flush to upper surface.
 B: Batts fitted together mid-depth. Data covers flush to upper surface.
 C: Batts fitted together flush to upper surface.



Appendix UL-EU CERTIFICATE

Certificate No. UL-EU-01058-CPR
Page 117/144
Date of Issue 2017-10-27

Cables and Cable Carriers – Single Batt Compression

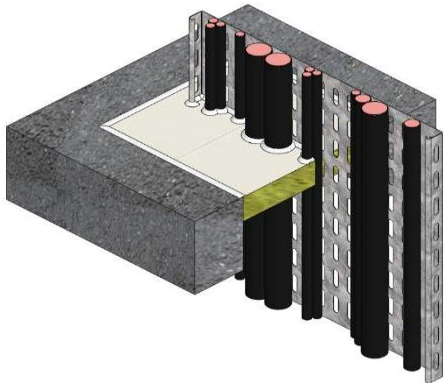
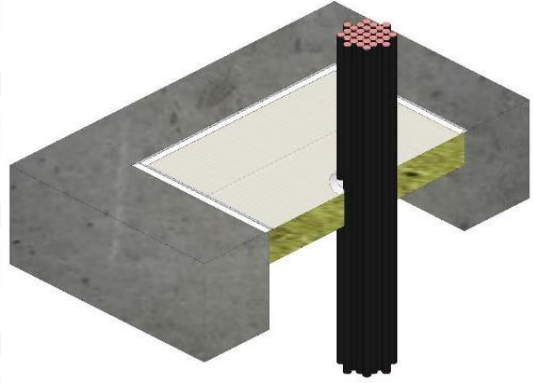
Cables, Metal Cable Trays, Trunking, Baskets and Ladders passing through Rigid Floors as identified below, protected by single compressed FB750 Intubatt seal, sealed with FS702 Intumastic or FS712 Intucoat.	
Floor Details: Rigid Floors of minimum thickness as identified below, and with performance classified to EN 13501-2.	
Maximum Opening size: 350mm by 550mm. Multiple openings must be separated by a minimum of 200mm for fire resistance requirements. Check separation requirements with the system owner of the supporting construction.	
Installation Instructions: Single Layer board, compressed and bonded into the aperture flush with upper surface of the floor. FB750 Intubatt should be installed in as few cut pieces as possible and tightly compressed to two opposite sides. This is achieved by the addition of 2mm to the required cut dimension. Compression may be applied - FB750 Intubatt to FB750 Intubatt, FB750 Intubatt to non-combustible service, or FB750 Intubatt to Substrate. Compression must be achieved over a minimum 60% of the FB750 Intubatt Compressed edge. If compression is achieved between two opposite sides of FB750 Intubatt, the perpendicular sides are not required to be compressed (the non-compressed seal should be fully abutted and bonded). All joints are to be bonded using FS712 Intucoat to full width of the FB750 Intubatt or FS702 Intumastic applied as a 10mm bead along the full-length joint centre line. FS702 Intumastic should be used to point all service and substrate interfaces, to a minimum of a 6mm bead. Apertures for penetrating services are to be tightly fitted and sealed. Imperfections should be filled with FS702 Intumastic to the full depth of the FB750 Intubatt. Service openings should be cut no more than 15mm away from non-combustible services, and/or, openings should be cut to suit the requirements of any additional required Nullfire product, if the service type is combustible or insulated CS or LS. (Imperfections in cut on a compressed edge may not exceed 40% of the area available to receive compression)	
The results below are also applicable when using multiple layers of FB750 Intubatt compressed in the opening and using single/ multiple layers of surface mounted FB750 Intubatt on the upper face.	
	

Form-ULID-006104 (DCS:27-CP-F0855) 5.0



Appendix UL-EU CERTIFICATE

Certificate No. UL-EU-01058-CPR
 Page 118/144
 Date of Issue 2017-10-27

Service	Integrity	Integrity & Insulation	Rigid Floor Thickness (mm)	Additional Requirements
	E (mins)	EI (mins)	≥ 150	
Metal Cable Trays, Trunking, Baskets and Ladder ≤ 500mm width and ≥ 1mm thickness	60	30	✓	-
≤ 2 type B cables, each cable ≤ 19mm diameter	60	30	✓	-
1 type C1 cable ≤ 4mm diameter	60	30	✓	-
1 type C2 cable ≤ 50mm diameter	60	30	✓	-
1 type C3 cable ≤ 37mm diameter	60	30	✓	-
1 type G1 cable ≤ 15mm diameter	60	30	✓	-
1 type G2 cable ≤ 20mm diameter	60	30	✓	-

Cable diameters can be increased up to 25%, and cable bundle diameters can be increased up to 10%



Appendix UL-EU CERTIFICATE

Certificate No. UL-EU-01058-CPR
Page 119/144
Date of Issue 2017-10-27

Cables and Cable Carriers – Double Batt Compression Batt Box

Cables, Metal Cable Trays, Trunking, Baskets and Ladders insulated within a batt box passing through Rigid Floors as identified below, protected by double compressed FB750 Intubatt seal, sealed with FS702 Intumastic.

Floor Details: Rigid Floors of minimum thickness as identified below, and with performance classified to EN 13501-2.

Maximum Opening size: 1800mm by 600mm. Multiple openings must be separated by a minimum of 200mm for fire resistance requirements. Check separation requirements with the system owner of the supporting construction.

Installation Instructions: Double Layer board, compressed and bonded into the aperture within the floor. FB750 Intubatt should be installed in as few cut pieces as possible and tightly compressed to two opposite sides. This is achieved by the addition of 2mm to the required cut dimension. Compression may be applied - FB750 Intubatt to FB750 Intubatt, FB750 Intubatt to non-combustible service, or FB750 Intubatt to Substrate. Compression must be achieved over a minimum 60% of the FB750 Intubatt Compressed edge. If compression is achieved between two opposite sides of FB750 Intubatt, the perpendicular sides are not required to be compressed (the non-compressed seal should be fully abutted and bonded). All joints are to be bonded using FS712 Intucoat to full width of the FB750 Intubatt or FS702 Intumastic applied as a 10mm bead along the full-length joint centre line. FS702 Intumastic should be used to point all service and substrate interfaces, to a minimum of a 6mm bead. Apertures for penetrating services are to be tightly fitted and sealed. Imperfections should be filled with FS702 Intumastic to the full depth of the FB750 Intubatt. (Imperfections in cut on a compressed edge may not exceed 40% of the area available to receive compression). Cut FB750 Intubatt to form batt box detail around cable tray(s) as per detail drawing below.

FS702 Intumastic or FS712 Intucoat is to be used to bond and form a seal between the batt box and the double batt seal and the abutment of the floor and board to board joints. Position the batt box around the penetration and position the centre of the batt box in line with the centre of the proposed FB750 Intubatt seal. The remaining aperture within the batt box should be completely filled with FI064 Soft Joint Filler and coated to upper face with 3mm WFT FS702 Intumastic. Batt Box is only required to be installed round cables, trays (perforated or non-perforated), ladders, baskets and trunking. If included within a mixed penetration seal, the rest of the seal should be completed as per the normal double batt requirement.

The results below are also applicable when using multiple layers of FB750 Intubatt compressed in the opening, including double/multiple layers of surface mounted FB750 Intubatt to the upper face.

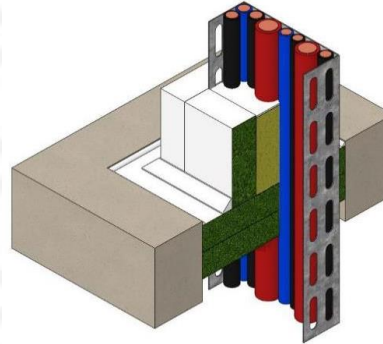

Form-ULID-006104 (DCS:27-CP-F0855) 5.0



Appendix UL-EU CERTIFICATE

Certificate No. UL-EU-01058-CPR
 Page 120/144
 Date of Issue 2017-10-27

Service	Integrity	Integrity & Insulation	Rigid Floor Thickness (mm)
	E (mins)	EI (mins)	≥ 150
Metal Cable Trays, Trunking, Baskets and Ladders ≤ 500mm width	120	120	✓
Bundle of ≤ 10 type A1 cables, each cable ≤ 12mm diameter	120	120	✓
Bundle of ≤ 10 type A2 cables, each cable ≤ 12mm diameter	120	120	✓
Bundle of ≤ 10 type A3 cables, each cable ≤ 12mm diameter	120	120	✓
1 type C1 cable ≤ 41mm diameter	120	120	✓
1 type C2 cable ≤ 50mm diameter	120	120	✓
1 type C3 cable ≤ 37mm diameter	120	120	✓
1 type D1 cable ≤ 55mm diameter	120	120	✓
1 type D2 cable ≤ 65mm diameter	120	120	✓
1 type D3 cable ≤ 52.5mm diameter	120	120	✓
Bundle of ≤ 100mm diameter type F data cables, each cable ≤ 13mm diameter	120	120	✓
1 type G1 cable ≤ 15mm diameter	120	120	✓
1 type G2 cable ≤ 20mm diameter	120	120	✓
≤ 2 type B cables, each cable ≤ 19mm diameter	120	90	✓
≤ 2 type E cables ≤ 25mm diameter	120	90	✓

Cable diameters can be increased up to 25%, and cable bundle diameters can be increased up to 10%



Appendix UL-EU CERTIFICATE

Certificate No. UL-EU-01058-CPR
Page 121/144
Date of Issue 2017-10-27

Combustible Pipes – Double Batt Pattress

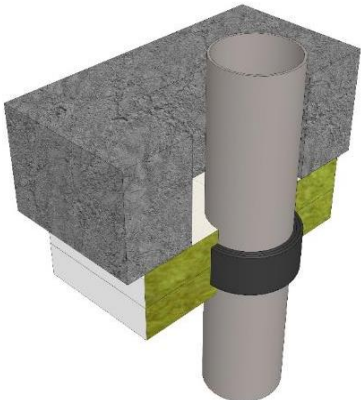
Combustible Pipes Uninsulated passing through Rigid Floors as identified below, protected by double pattress (surface mounted) FB750 Intubatt seal, sealed with FS702 Intumastic or FS712 Intucoat.
Floor Details: Rigid Floor of minimum thickness as identified below, and with performance classified to EN 13501-2.
Maximum Opening size: 400mm by 400mm. Multiple apertures must be separated by a minimum of 200mm for fire resistance requirements. Check separation requirements with the system owner of the supporting construction.
Installation Instructions: Double layer board, surface mounted (pattress fit) on under side of the floor with a minimum 75mm overlap around the opening. The overlap should be bonded with a 10mm bead of FS702 Intumastic placed 20-60mm from the board edges, and additionally mechanically restrained using 75mm steel screws with a 25mm washer at maximum 300mm centres, 10-65mm from the board perimeter and no more than 50mm from a board joint. A low torque setting should be used to ensure that the embedment of fixing into the board does not exceed 15mm. The fixings may be left exposed or covered using FS702 Intumastic. The FB750 Intubatt should be installed in as few cut pieces as possible. All joints are to be bonded using FS712 Intucoat to full width of the FB750 Intubatt or FS702 Intumastic applied as a 10mm bead along the full-length joint centre line. FS702 Intumastic should be used to point all service and substrate interfaces, to a minimum of a 6mm bead. Apertures for penetrating services are to be tightly fitted and sealed. Imperfections should be filled with FS702 Intumastic to the full depth of the FB750 Intubatt. Service openings should be cut no more than 15mm away from non-combustible services, and/or, openings should be cut to suit the requirements of any additional required Nullifire product, if the service type is combustible or insulated CS or LS. External sides of the Board may be required to be coated for aesthetic reasons or to prevent fibre migration.
The results below are also applicable when using multiple layers of surface mounted FB750 Intubatt to the underside of the floor, or double / multiple layers compressed and bonded within the floor, or double / multiple layers to the upper face of the floor.

Form-ULID-006104 (DCS:27-CP-F0855) 5.0



Appendix UL-EU CERTIFICATE

Certificate No. UL-EU-01058-CPR
 Page 122/144
 Date of Issue 2017-10-27

Service	Pipe Diameter	Pipe Wall Thickness	Pipe End Configuration		Integrity	Integrity & Insulation	Rigid Floor Thickness (mm)	Additional Requirements
	(mm)	(mm)	C/C	U/C	E (mins)	EI (mins)	≥ 150	
HDPE pipe	≤ 55	3.2	✓	✓	60	60	✓	1 layer of FP302 Intustrap, central to the seal, sealed within FB750 Intubatt with FS702 Intumastic



Appendix UL-EU CERTIFICATE

Certificate No. UL-EU-01058-CPR
Page 123/144
Date of Issue 2017-10-27

Combustible Pipes – Double Batt Compression

Combustible Pipes passing through Rigid Floors as identified below, protected by double compressed FB750 Intubatt seal, sealed with FS702 Intumastic or FS712 Intucoat.

Floor Details: Rigid Floors of minimum thickness as identified below, and with performance classified to EN 13501-2.

Maximum Opening size: 1100mm by 1100mm. Multiple apertures must be separated by a minimum of 200mm for fire resistance requirements. Check separation requirements with the system owner of the supporting construction.

Installation Instructions: Double Layer board, compressed and bonded into the aperture within the floor, unless otherwise stated. FB750 Intubatt should be installed in as few cut pieces as possible and tightly compressed to two opposite sides. This is achieved by the addition of 2mm to the required cut dimension. Compression may be applied - FB750 Intubatt to FB750 Intubatt, FB750 Intubatt to non-combustible service, or FB750 Intubatt to Substrate. Compression must be achieved over a minimum 60% of the FB750 Intubatt Compressed edge. If compression of FB750 Intubatt is achieved between two opposite sides, the perpendicular sides are not required to be compressed (the non-compressed seal should be fully abutted and bonded). All joints are to be bonded using FS712 Intucoat to full width of the FB750 Intubatt or FS702 Intumastic applied as a 10mm bead along the full-length joint centre line. FS702 Intumastic should be used to point all service and substrate interfaces, to a minimum of a 6mm bead. Apertures for penetrating services are to be tightly fitted and sealed. Imperfections should be filled with FS702 Intumastic to the full depth of the FB750 Intubatt. Service openings should be cut no more than 15mm away from non-combustible services, and/or, openings should be cut to suit the requirements of any additional required Nullifire product, if the service type is combustible or insulated CS or LS. (Imperfections in cut on a compressed edge may not exceed 40% of the area available to receive compression)

The results below are also applicable when using multiple layers of FB750 Intubatt compressed in the opening, including double/multiple layers of surface mounted FB750 Intubatt to the upper face.

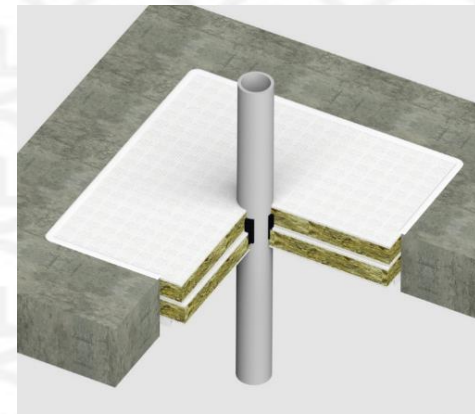
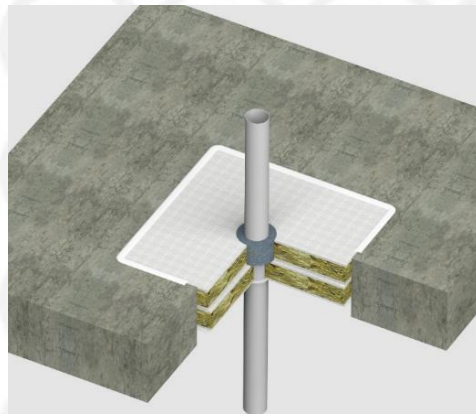

Form-ULID-006104 (DCS:27-CP-F0855) 5.0



Appendix UL-EU CERTIFICATE

Certificate No. UL-EU-01058-CPR
 Page 124/144
 Date of Issue 2017-10-27

Service		Pipe Diameter	Pipe Wall Thickness	Pipe End Configuration		Integrity	Integrity & Insulation	Rigid Floor Thickness (mm)	Additional Requirements
		(mm)	(mm)	C/C	U/C	E (mins)	EI (mins)	≥ 150	
ABS pipe	A	≤ 55	3.2	✓	✓	240	180	✓	1 layer of FP302 Intustrap, central to the seal, sealed within FB750 Intubatt with FS702 Intumastic
ABS pipe	B	≤ 110	7.3	✓	✓	60	60	✓	20mm annulus of FS709 HP Intumescent Sealant, 50mm depth
ABS pipe	B	≤ 90	6,0	✓	✓	60	60	✓	20mm annulus of FS709 HP Intumescent Sealant, 50mm depth
ABS pipe	B	≤ 110	11.2	✓	✓	60	60	✓	20mm annulus of FS709 HP Intumescent Sealant, 50mm depth
ABS pipe	B	≤ 114	11.2	✓	✓	60	60	✓	3 layers of FP302 Intustrap, central to the seal, sealed within FB750 Intubatt with FS702 Intumastic
ABS pipe	B	≤ 114	7.3	✓	✓	60	60	✓	3 layers of FP302 Intustrap, central to the seal, sealed within FB750 Intubatt with FS702 Intumastic
ABS pipe	B	≤ 90	6,0	✓	✓	60	60	✓	2 layers of FP302 Intustrap, central to the seal, sealed within FB750 Intubatt with FS702 Intumastic
ABS pipe	B	≤ 40	2.7	✓	✓	60	60	✓	1 layer of FP302 Intustrap, central to the seal, sealed within FB750 Intubatt with FS702 Intumastic
ABS pipe	B	≤ 40	2.7	✓	✓	60	60	✓	20mm annulus of FS709 HP Intumescent Sealant, 50mm depth
PVC-U pipe (+ PVC-C)	C	≤ 160	3.2	✓	✓	180	120	✓	4 layers of FP302 Intustrap, central to the seal, sealed within FB750 Intubatt with FS702 Intumastic
PVC-U pipe (+ PVC-C)	B	≤ 125	7.4	✓	✓	60	60	✓	20mm annulus of FS709 HP Intumescent Sealant, 50mm depth
PVC-U pipe (+ PVC-C)	B	≤ 40	1.9	✓	✓	60	60	✓	20mm annulus of FS709 HP Intumescent Sealant, 50mm depth

Form-ULID-006104 (DCS:27-CP-F0855) 5.0



Appendix UL-EU CERTIFICATE

Certificate No. UL-EU-01058-CPR
 Page 125/144
 Date of Issue 2017-10-27

Service		Pipe Diameter	Pipe Wall Thickness	Pipe End Configuration		Integrity	Integrity & Insulation	Rigid Floor Thickness (mm)	Additional Requirements
		(mm)	(mm)	C/C	U/C	E (mins)	EI (mins)	≥ 150	
PVC-U pipe (+ PVC-C)	B	≤ 90	5.4	✓	✓	60	60	✓	20mm annulus of FS709 HP Intumescent Sealant, 50mm depth
PVC-U pipe (+ PVC-C)	B	≤ 125	4.8	✓	✓	60	60	✓	20mm annulus of FS709 HP Intumescent Sealant, 50mm depth
PVC-U pipe (+ PVC-C)	A	≤ 110	3.2	✓	✓	60	60	✓	2 layers of FP302 Intustrap, central to the seal, sealed within FB750 Intubatt with FS702 Intumastic
PVC-U pipe (+ PVC-C)	B	≤ 125	7.4	✓	✓	60	60	✓	3 layers of FP302 Intustrap, central to the seal, sealed within FB750 Intubatt with FS702 Intumastic
PVC-U pipe (+ PVC-C)	B	≤ 40	1.9	✓	✓	60	60	✓	1 layer of FP302 Intustrap, central to the seal, sealed within FB750 Intubatt with FS702 Intumastic
PVC-U pipe (+ PVC-C)	B	≤ 90	5.4	✓	✓	60	60	✓	3 layers of FP302 Intustrap, central to the seal, sealed within FB750 Intubatt with FS702 Intumastic
PVC-U pipe (+ PVC-C)	B	≤ 125	4.8	✓	✓	60	60	✓	4 layers of FP302 Intustrap, central to the seal, sealed within FB750 Intubatt with FS702 Intumastic



Appendix UL-EU CERTIFICATE

Certificate No. UL-EU-01058-CPR
 Page 126/144
 Date of Issue 2017-10-27

Service	Pipe Diameter	Pipe Wall Thickness	Pipe End Configuration		Integrity	Integrity & Insulation	Rigid Floor Thickness (mm)	Additional Requirements	
			C/C	U/C					E (mins)
PE pipe (+ ABS, San+ PVC, PVC-U & PVC-C)	B	≤ 40	3.7	✓	✓	60	60	✓	20mm annulus of FS709 HP Intumescent Sealant, 50mm depth
PE pipe (+ ABS, San+ PVC, PVC-U & PVC-C)	B	≤ 110	6.6	✓	✓	60	60	✓	20mm annulus of FS709 HP Intumescent Sealant, 50mm depth
PE pipe (+ ABS, San+ PVC, PVC-U & PVC-C)	B	≤ 110	6.6	✓	✓	60	60	✓	2 layers of FP302 Intustrap, central to the seal, sealed within FB750 Intubatt with FS702 Intumastic
PE pipe (+ ABS, San+ PVC, PVC-U & PVC-C)	B	≤ 40	3.7	✓	✓	60	60	✓	1 layer of FP302 Intustrap, central to the seal, sealed within FB750 Intubatt with FS702 Intumastic
PE pipe (+ ABS, San+ PVC, PVC-U & PVC-C)	B	≤ 110	3.4	✓	✓	60	60	✓	20mm annulus of FS709 HP Intumescent Sealant, 50mm depth
PE pipe (+ ABS, San+ PVC, PVC-U & PVC-C)	B	≤ 110	3.4	✓	✓	60	60	✓	3 layers of FP302 Intustrap, central to the seal, sealed within FB750 Intubatt with FS702 Intumastic
HDPE pipe	B	≤ 90	8.2	✓	✓	60	60	✓	1 layer of FP302 Intustrap, central to the seal, sealed within FB750 Intubatt with FS702 Intumastic
HDPE pipe	C	≤ 90	8.2	✓	✓	60	60	✓	20mm annulus of FS709 HP Intumescent Sealant, 50mm depth
PP pipe	B	≤ 110	10.0	✓	✓	60	60	✓	20mm annulus of FS709 HP Intumescent Sealant, 50mm depth
PP pipe	B	≤ 90	8.2	✓	✓	60	60	✓	20mm annulus of FS709 HP Intumescent Sealant, 50mm depth
PP pipe	B	≤ 40	1.8	✓	✓	60	60	✓	20mm annulus of FS709 HP Intumescent Sealant, 50mm depth
PP pipe	B	≤ 90	8.2	✓	✓	60	60	✓	3 layers of FP302 Intustrap, central to the seal, sealed within FB750 Intubatt with FS702 Intumastic



Appendix UL-EU CERTIFICATE

Certificate No. UL-EU-01058-CPR
 Page 127/144
 Date of Issue 2017-10-27

Service		Pipe Diameter	Pipe Wall Thickness	Pipe End Configuration		Integrity	Integrity & Insulation	Rigid Floor Thickness (mm)	Additional Requirements
		(mm)	(mm)	C/C	U/C	E (mins)	EI (mins)	≥ 150	
PP pipe	B	≤ 110	10,0	✓	✓	60	60	✓	3 layers of FP302 Intustrap, central to the seal, sealed within FB750 Intubatt with FS702 Intumastic
PP pipe	B	≤ 40	1.8	✓	✓	60	60	✓	2 layers of FP302 Intustrap, central to the seal, sealed within FB750 Intubatt with FS702 Intumastic
PP pipe	B	≤ 110	2.7	✓	✓	60	60	✓	3 layers of FP302 Intustrap, central to the seal, sealed within FB750 Intubatt with FS702 Intumastic

A: Batts fitted together, flush to lower surface. Data covers applications mid-depth or flush to upper surface.

B: Batts fitted together flush to upper surface.

C: First Batt fitted flush with top surface in compression. Second Batt fitted on top of first batt surface with a minimum overlap of 75mm from service over batt only or substrate (as required).



Appendix UL-EU CERTIFICATE

Certificate No. UL-EU-01058-CPR
Page 128/144
Date of Issue 2017-10-27

Combustible Pipes – Multiple Batt Pattress

Combustible Pipes Insulated with No insulation passing through Rigid Floors as identified below, protected by multiple pattress (surface mounted) FB750 Intubatt seal, sealed with FS702 Intumastic or FS712 Intucoat.

Floor Details: Rigid Floors of minimum thickness as identified below, and with performance classified to EN 13501-2.

Maximum Opening size: Circular hole appropriate to the pipe in consideration. Multiple apertures must be separated by a minimum of 200mm for fire resistance requirements. Check separation requirements with the system owner of the supporting construction.

Installation Instructions: Multiple layer board, surface mounted (pattress fit) on under side of the floor with a minimum 75mm overlap around the opening. The overlap should be bonded with a 10mm bead of FS702 Intumastic placed 20-60mm from the board edges, and additionally mechanically restrained using 75mm steel screws with a 25mm washer at maximum 300mm centres, 10-65mm from the board perimeter and no more than 50mm from a board joint. A low torque setting should be used to ensure that the embedment of fixing into the board does not exceed 15mm. The fixings may be left exposed or covered using FS702 Intumastic. The FB750 Intubatt should be installed in as few cut pieces as possible. All joints are to be bonded using FS712 Intucoat to full width of the FB750 Intubatt or FS702 Intumastic applied as a 10mm bead along the full-length joint centre line. FS702 Intumastic should be used to point all service and substrate interfaces, to a minimum of a 6mm bead. Apertures for penetrating services are to be tightly fitted and sealed. Imperfections should be filled with FS702 Intumastic to the full depth of the FB750 Intubatt. Service openings should be cut no more than 15mm away from non-combustible services, and/or, openings should be cut to suit the requirements of any additional required Nullifire product, if the service type is combustible or insulated CS or LS. External sides of the Board may be required to be coated for aesthetic reasons or to prevent fibre migration.

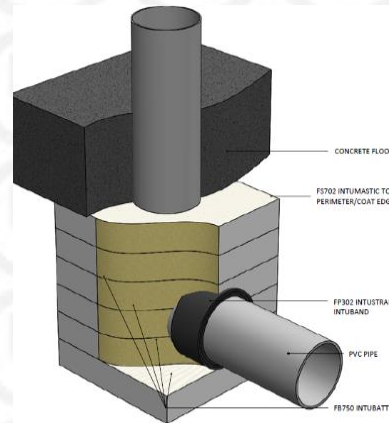

Form-ULID-006104 (DCS:27-CP-F0855) 5.0



Appendix UL-EU CERTIFICATE

Certificate No. UL-EU-01058-CPR
 Page 129/144
 Date of Issue 2017-10-27

Service	Pipe Diameter	Pipe Wall Thickness	Pipe End Configuration		Integrity	Integrity & Insulation	Rigid Floor Thickness (mm)	Additional Requirements
	(mm)	(mm)	C/C	U/C	E (mins)	EI (mins)	≥ 150	
PVC-U pipe (+ PVC-C)	≤ 110	4,8	✓	✓	180	120	✓	7 layers of FB750 Intubatt (400mm x 350mm) placed around the elbow of the pipe + 3 layers of FP302 Intustrap, where the pipe exits the seal, sealed within FB750 Intubatt with FS702 Intumastic
PVC-U pipe (+ PVC-C)	≤ 50	2,0	✓	✓	240	240	✓	4 layers of FB750 Intubatt (400mm x 350mm) placed around the elbow of the pipe + 1 layer of FP302 Intustrap, where the pipe exits the seal, sealed within FB750 Intubatt with FS702 Intumastic



Appendix UL-EU CERTIFICATE

Certificate No. UL-EU-01058-CPR
Page 130/144
Date of Issue 2017-10-27

Non-Combustible Pipes – Double Batt Pattress

Non-Combustible Pipes through Rigid Floors as identified below, protected by double pattress (surface mounted) FB750 Intubatt seal, sealed with FS702 Intumastic or FS712 Intucoat.

Floor Details: Rigid Floors of minimum thickness as identified below, and with performance classified to EN 13501-2.

Maximum Opening size: 500mm by 500mm. Multiple openings must be separated by a minimum of 200mm for fire resistance requirements. Check separation requirements with the system owner of the supporting construction.

Installation Instructions: Double layer board, surface mounted (pattress fit) on under side of the floor with a minimum 75mm overlap around the opening. The overlap should be bonded with a 10mm bead of FS702 Intumastic placed 20-60mm from the board edges, and additionally mechanically restrained using 75mm steel screws with a 25mm washer at maximum 300mm centres, 10-65mm from the board perimeter and no more than 50mm from a board joint. A low torque setting should be used to ensure that the embedment of fixing into the board does not exceed 15mm. The fixings may be left exposed or covered using FS702 Intumastic. The FB750 Intubatt should be installed in as few cut pieces as possible. All joints are to be bonded using FS712 Intucoat to full width of the FB750 Intubatt or FS702 Intumastic applied as a 10mm bead along the full-length joint centre line. FS702 Intumastic should be used to point all service and substrate interfaces, to a minimum of a 6mm bead. Apertures for penetrating services are to be tightly fitted and sealed. Imperfections should be filled with FS702 Intumastic to the full depth of the FB750 Intubatt. Service openings should be cut no more than 15mm away from non-combustible services, and/or, openings should be cut to suit the requirements of any additional required Nullifire product, if the service type is combustible or insulated CS or LS. External sides of the Board may be required to be coated for aesthetic reasons or to prevent fibre migration.

The results below are also applicable when using multiple layers of surface mounted FB750 Intubatt to the underside of the floor, or double / multiple layers compressed and bonded within the floor, or double / multiple layers to the upper face of the floor.

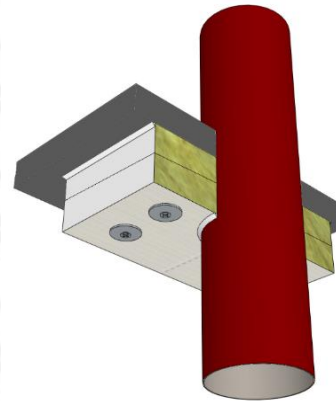

Form-ULID-006104 (DCS:27-CP-F0855) 5.0



Appendix UL-EU CERTIFICATE

Certificate No. UL-EU-01058-CPR
 Page 131/144
 Date of Issue 2017-10-27

Service			Pipe Diameter	Pipe Wall Thickness#	Pipe End Configuration		Integrity	Integrity & Insulation	Rigid Floor Thickness (mm)	Additional Requirements
Cast Iron	Steel	Copper	(mm)	(mm)	C/C	C/U	E (mins)	EI (mins)	≥ 150	
✓	✓		≤ 160	≥ 6	✓	✓	120	30	✓	-
✓	✓		≤ 220	≥ 6.9	✓	✓	60	15	✓	-

#Up to maximum 14.2 mm



Appendix UL-EU CERTIFICATE

Certificate No. UL-EU-01058-CPR
Page 132/144
Date of Issue 2017-10-27

Non-Combustible Pipes – Double Batt Compress

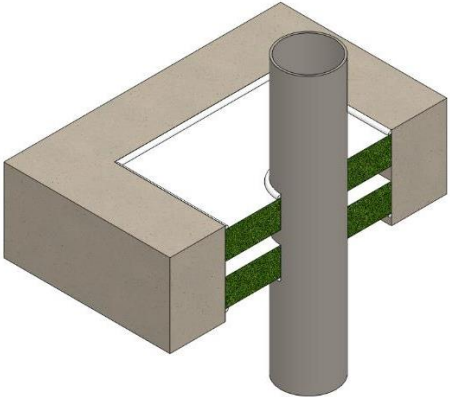
Non-Combustible Pipes through Rigid Floors as identified below, protected by double compressed FB750 Intubatt seal, sealed with FS702 Intumastic or FS712 Intucoat.
Floor Details: Rigid Floors of minimum thickness as identified below, and with performance classified to EN 13501-2.
Maximum Opening size: 1800mm by 600mm. Multiple apertures must be separated by a minimum of 200mm for fire resistance requirements. Check separation requirements with the system owner of the supporting construction.
Installation Instructions: Double Layer board, compressed and bonded into the aperture flush with upper surface of the floor, unless otherwise stated. FB750 Intubatt should be installed in as few cut pieces as possible and tightly compressed to two opposite sides. This is achieved by the addition of 2mm to the required cut dimension. Compression may be applied - FB750 Intubatt to FB750 Intubatt, FB750 Intubatt to non-combustible service, or FB750 Intubatt to Substrate. Compression must be achieved over a minimum 60% of the FB750 Intubatt Compressed edge. If compression of FB750 Intubatt is achieved between two opposite sides, the perpendicular sides are not required to be compressed (the non-compressed seal should be fully abutted and bonded). All joints are to be bonded using FS712 Intucoat to full width of the FB750 Intubatt or FS702 Intumastic applied as a 10mm bead along the full-length joint centre line. FS702 Intumastic should be used to point all service and substrate interfaces, to a minimum of a 6mm bead. Apertures for penetrating services are to be tightly fitted and sealed. Imperfections should be filled with FS702 Intumastic to the full depth of the FB750 Intubatt. Service openings should be cut no more than 15mm away from non-combustible services, and/or, openings should be cut to suit the requirements of any additional required Nullifire product, if the service type is combustible or insulated CS or LS. (Imperfections in cut on a compressed edge may not exceed 40% of the area available to receive compression)
The results below are also applicable when using multiple layers of FB750 Intubatt compressed in the opening, including double/multiple layers of surface mounted FB750 Intubatt to the upper face.

Form-ULID-006104 (DCS:27-CP-F0855) 5.0



Appendix UL-EU CERTIFICATE

Certificate No. UL-EU-01058-CPR
 Page 133/144
 Date of Issue 2017-10-27

Service			Pipe Diameter	Pipe Wall Thickness#	Pipe End Configuration		Integrity	Integrity & Insulation	Rigid Floor Thickness (mm)	Additional Requirements
Cast Iron	Steel	Copper	(mm)	(mm)	C/C	C/U	E (mins)	EI (mins)	≥ 150	
✓	✓		≤ 220	≥ 8.5	✓	✓	120	15	✓	-

#Up to maximum 14.2 mm



Appendix UL-EU CERTIFICATE

Certificate No. UL-EU-01058-CPR
Page 134/144
Date of Issue 2017-10-27

Non-Combustible Pipes Insulated CS – Double Batt Pattress

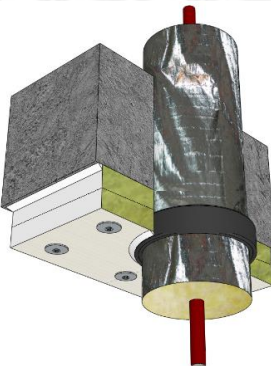
Non-Combustible Pipes Insulated with Continuous Sustained Insulation passing through Rigid Floors as identified below, protected by double pattress (surface mounted) FB750 Intubatt seal, sealed with FS702 Intumastic or FS712 Intucoat.
Floor Details: Rigid Floors of minimum thickness as identified below, and with performance classified to EN 13501-2.
Maximum Opening size: 400mm by 400mm. Multiple apertures must be separated by a minimum of 200mm for fire resistance requirements. Check separation requirements with the system owner of the supporting construction.
Installation Instructions: Double layer board, surface mounted (pattress fit) on under side of the floor with a minimum 75mm overlap around the aperture. (Overlap on the lowest edge can be reduced to 30mm in the event of an obstruction preventing the 75mm overlap). The overlap should be bonded with a 10mm bead of FS702 Intumastic placed 20-60mm from the board edges, and additionally mechanically restrained using 75mm steel screws with a 25mm washer at maximum 300mm centres, 10-65mm from the board perimeter and no more than 50mm from a board joint. A low torque setting should be used to ensure that the embedment of fixing into the board does not exceed 15mm. The fixings may be left exposed or covered using FS702 Intumastic. The FB750 Intubatt should be installed in as few cut pieces as possible. All joints are to be bonded using FS712 Intucoat to full width of the FB750 Intubatt or FS702 Intumastic applied as a 10mm bead along the full-length joint centre line. FS702 Intumastic should be used to point all service and substrate interfaces, to a minimum of a 6mm bead. Apertures for penetrating services are to be tightly fitted and sealed. Imperfections should be filled with FS702 Intumastic to the full depth of the FB750 Intubatt. Service openings should be cut no more than 15mm away from non-combustible services, and/or, openings should be cut to suit the requirements of any additional required Nullifire product, if the service type is combustible or insulated CS or LS. External sides of the Board may be required to be coated for aesthetic reasons or to prevent fibre migration.
The results below are also applicable when using multiple layers of surface mounted FB750 Intubatt to the underside of the floor, or double / multiple layers compressed and bonded within the floor, or double / multiple layers to the upper face of the floor.

Form-ULID-006104 (DCS:27-CP-F0855) 5.0



Appendix UL-EU CERTIFICATE

Certificate No. UL-EU-01058-CPR
 Page 135/144
 Date of Issue 2017-10-27

Service			CS Pipe Insulation (Continuous Sustained)		Pipe Diameter	Pipe Wall Thickness#	Pipe End Configuration		Integrity	Integrity & Insulation	Rigid Floor Thickness (mm)	Additional Requirements
Cast Iron	Steel	Copper	Material	Thickness (mm)	(mm)	(mm)	C/C	C/U	E (mins)	EI (mins)	≥ 150	
✓	✓		Nitrile (Elastomeric)	40	≤ 220	≥ 6	✓	✓	240	30	✓	2 layers of FP302 Intustrap (Central to seal) sealed within FB750 Intubatt with FS702 Intumastic
✓	✓		Glass Fibre	≥ 50	≤ 220	≥ 6	✓	✓	90	30	✓	2 layers of FP302 Intustrap (Central to seal) sealed within FB750 Intubatt with FS702 Intumastic
#Up to maximum 14.2 mm												



Appendix UL-EU CERTIFICATE

Certificate No. UL-EU-01058-CPR
Page 136/144
Date of Issue 2017-10-27

Non-Combustible Pipe Insulated CS – Double Batt Compress

Non-Combustible Pipes Insulated with Continuous Sustained Insulation passing through Rigid Floors as identified below, protected by double compressed FB750 Intubatt seal, sealed with FS702 Intumastic or FS712 Intucoat.

Floor Details: Rigid Floors of minimum thickness as identified below, and with performance classified to EN 13501-2.

Maximum Opening size: 400mm by 400mm. Multiple apertures must be separated by a minimum of 200mm for fire resistance requirements. Check separation requirements with the system owner of the supporting construction.

Installation Instructions: Double Layer board, compressed and bonded into the aperture flush with upper surface of the floor, unless otherwise stated. FB750 Intubatt should be installed in as few cut pieces as possible and tightly compressed to two opposite sides. This is achieved by the addition of 2mm to the required cut dimension. Compression may be applied - FB750 Intubatt to FB750 Intubatt, FB750 Intubatt to non-combustible service, or FB750 Intubatt to Substrate. Compression must be achieved over a minimum 60% of the FB750 Intubatt Compressed edge. If compression of FB750 Intubatt is achieved between two opposite sides, the perpendicular sides are not required to be compressed (the non-compressed seal should be fully abutted and bonded). All joints are to be bonded using FS712 Intucoat to full width of the FB750 Intubatt or FS702 Intumastic applied as a 10mm bead along the full-length joint centre line. FS702 Intumastic should be used to point all service and substrate interfaces, to a minimum of a 6mm bead. Apertures for penetrating services are to be tightly fitted and sealed. Imperfections should be filled with FS702 Intumastic to the full depth of the FB750 Intubatt. Service openings should be cut no more than 15mm away from non-combustible services, and/or, openings should be cut to suit the requirements of any additional required Nullifire product, if the service type is combustible or insulated CS or LS. (Imperfections in cut on a compressed edge may not exceed 40% of the area available to receive compression)

The results below are also applicable when using multiple layers of FB750 Intubatt compressed in the opening, including double/multiple layers of surface mounted FB750 Intubatt to the upper face.

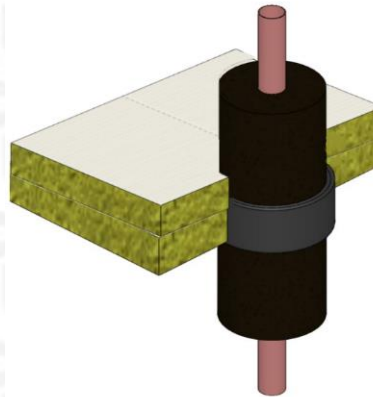

Form-ULID-006104 (DCS:27-CP-F0855) 5.0



Appendix UL-EU CERTIFICATE

Certificate No. UL-EU-01058-CPR
 Page 137/144
 Date of Issue 2017-10-27

Service			CS Pipe Insulation (Continuous Sustained)		Pipe Diameter	Pipe Wall Thickness#	Pipe End Configuration		Integrity	Integrity & Insulation	Rigid Floor Thickness (mm)	Additional Requirements
Cast Iron	Steel	Copper	Material	Thickness (mm)	(mm)	(mm)	C/C	C/U	E (mins)	EI (mins)	≥ 150	
✓	✓	✓	Glass Fibre	≥ 50	≤ 22	≥ 0.8	✓	✓	120	120	✓	2 layers of FP302 Intustrap, flush with lower face of seal, sealed within FB750 Intubatt with FS702 Intumastic
✓	✓	✓	Nitrile (Elastomeric)	35	≤ 22	≥ 0.8	✓	✓	120	120	✓	2 layers of FP302 Intustrap, flush with lower face of seal, sealed within FB750 Intubatt with FS702 Intumastic
✓	✓		Glass Fibre	≥ 50	≤ 220	≥ 6	✓	✓	90	30	✓	2 layers of FP302 Intustrap, flush with lower face of seal, sealed within FB750 Intubatt with FS702 Intumastic
✓	✓		Nitrile (Elastomeric)	38	≤ 220	≥ 6	✓	✓	30	30	✓	2 layers of FP302 Intustrap, flush with lower face of seal, sealed within FB750 Intubatt with FS702 Intumastic
✓	✓		Nitrile (Elastomeric)	60	≤ 160	≥ 6.9	✓	✓	60	15	✓	4 layers of FP302 Intustrap, central to the seal, sealed within FB750 Intubatt with FS702 Intumastic

#Up to maximum 14.2 mm



Appendix UL-EU CERTIFICATE

Certificate No. UL-EU-01058-CPR
Page 138/144
Date of Issue 2017-10-27

Non-Combustible Pipe Insulated CS – Single Batt Pattress

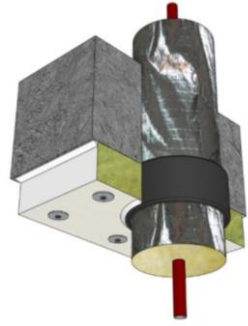
Non-Combustible Pipes Insulated with Continuous Sustained Insulation passing through Rigid Floors as identified below, protected by single pattress (surface mounted) FB750 Intubatt seal, sealed with FS702 Intumastic or FS712 Intucoat.
Floor Details: Rigid Floor of minimum thickness as identified below , and with performance classified to EN 13501-2.
Maximum Opening size: 400mm by 400mm. Multiple openings must be separated by a minimum of 200mm for fire resistance requirements. Check separation requirements with the system owner of the supporting construction.
Installation Instructions: Single layer Board surface mounted (pattress fit) to underside of the floor with a minimum 75mm overlap around the aperture. (Overlap on the lowest edge can be reduced to 30mm in the event of an obstruction preventing the 75mm overlap). The overlap should be bonded with a 10mm bead of FS702 Intumastic placed 20-60mm from the board edges, and additionally mechanically restrained using 75mm steel screws with a 25mm washer at maximum 300mm centres, 10-65mm from the board perimeter and no more than 50mm from a board joint. A low torque setting should be used to ensure that the embedment of fixing into the board does not exceed 15mm. The fixings may be left exposed or covered using FS702 Intumastic. The FB750 Intubatt should be installed in as few cut pieces as possible. All joints are to be bonded using FS712 Intucoat to full width of the FB750 Intubatt or FS702 Intumastic applied as a 10mm bead along the full-length joint centre line. FS702 Intumastic should be used to point all service and substrate interfaces, to a minimum of a 6mm bead. Apertures for penetrating services are to be tightly fitted and sealed. Imperfections should be filled with FS702 Intumastic to the full depth of the FB750 Intubatt. Service openings should be cut no more than 15mm away from non-combustible services, and/or, openings should be cut to suit the requirements of any additional required Nullifire product, if the service type is combustible or insulated CS or LS. External sides of the Board may be required to be coated for aesthetic reasons or to prevent fibre migration. (In situations where the required overlap cannot be achieved due to a perpendicular fire resisting wall / soffit, it is possible to reduce the overlap, down to as low as 0mm, provided the board edge is bonded to the adjoining compartment using a 10mm bead of FS702 Intumastic, and subsequently pointed to all mated edges)
The results below are also applicable when using multiple layers of surface mounted FB750 Intubatt to the underside of the floor, or single / multiple layer(s) compressed and bonded within the floor, or single / multiple layer(s) to the upper face of the floor.

Form-ULID-006104 (DCS:27-CP-F0855) 5.0



Appendix UL-EU CERTIFICATE

Certificate No. UL-EU-01058-CPR
 Page 139/144
 Date of Issue 2017-10-27

Service			CS Pipe Insulation (Continuous Sustained)		Pipe Diameter	Pipe Wall Thickness#	Pipe End Configuration		Integrity	Integrity & Insulation	Rigid Floor Thickness (mm)	Additional Requirements
Cast Iron	Steel	Copper	Material	Thickness (mm)	(mm)	(mm)	C/C	C/U	E (mins)	EI (mins)	≥ 150	
✓	✓		Glass Fibre	≥ 50	≤ 220	≥ 6	✓	✓	90	30	✓	2 layers of FP302 Intustrap, sealed within FB750 Intubatt with FS702 Intumastic
✓	✓		Nitrile (Elastomeric)	38	≤ 220	≥ 6	✓	✓	30	30	✓	2 layers of FP302 Intustrap, sealed within FB750 Intubatt with FS702 Intumastic

#Up to maximum 14.2 mm



Appendix UL-EU CERTIFICATE

Certificate No. UL-EU-01058-CPR
Page 140/144
Date of Issue 2017-10-27

Blank Seals – Double Batt Compress

Blank Seals installed in Rigid Floors as Identified below, protected by double compressed FB750 Intubatt seal, sealed with FS702 Intumastic or FS712 Intucoat.

Floor Details: Rigid Floors of minimum thickness as identified below, and with performance classified to EN 13501-2.

Maximum Opening size: See below. Multiple openings must be separated by a minimum of 200mm for fire resistance requirements. Check separation requirements with the system owner of the supporting construction.

Installation Instructions: Double Layer board, compressed and bonded into the aperture flush with upper surface of floor. FB750 Intubatt should be installed in as few cut pieces as possible and tightly compressed to two opposite sides. This is achieved by the addition of 2mm to the required cut dimension. Compression may be applied - FB750 Intubatt to FB750 Intubatt or FB750 Intubatt to Substrate. Compression must be achieved over a minimum 60% of the FB750 Intubatt compressed edge. If compression is achieved between two opposite sides of FB750 Intubatt, perpendicular sides are not required to be compressed (the non-compressed seal should be fully abutted and bonded). All joints are to be bonded using FS712 Intucoat to full width of the FB750 Intubatt or FS702 Intumastic applied as a 10mm bead along the full-length joint centre line. FS702 Intumastic should be used to point all service and substrate interfaces, to a minimum of a 6mm bead. Imperfections should be filled with FS702 Intumastic to the full depth of the FB750 Intubatt. (Imperfections in cut on a compressed edge may not exceed 40% of the area available to receive compression)

The results below are also applicable when using multiple layers of compressed and bonded FB750 Intubatt within the floor, or double / multiple layers to the upper face of the floor.

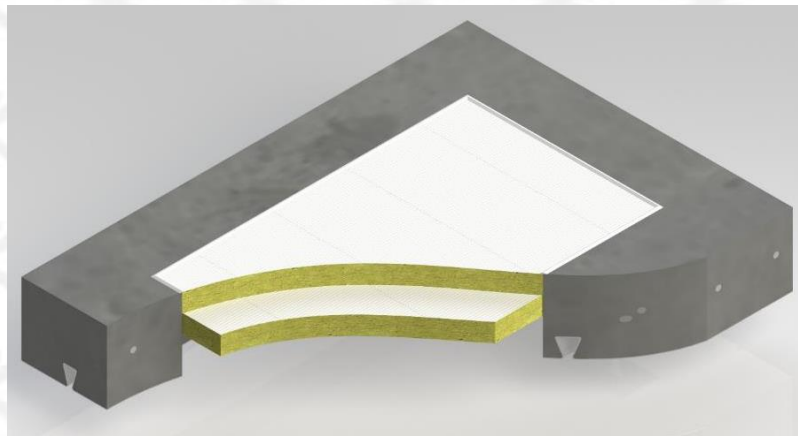

Form-ULID-006104 (DCS:27-CP-F0855) 5.0



Appendix UL-EU CERTIFICATE

Certificate No. UL-EU-01058-CPR
 Page 141/144
 Date of Issue 2017-10-27

Opening Size (mm)	Integrity	Integrity & Insulation	Rigid Floor Thickness (mm)	Additional Requirements
	E (mins)	EI (mins)	≥ 150	
≤ 450 x 400	120	120	✓	Opening framed with 95mm x 45mm European Redwood Cedar battens. Battens and FB750 Intubatt subsequently coated with 0.4mm DFT of Nullifire SC803 Intumescent Coating
≤ 350 x 400	120	120	✓	First Batt Fitted flush with lower surface of opening. Second batt surface mounted below opening with 75mm overlap
≤ 500 x 500	120	60	✓	-



Appendix UL-EU CERTIFICATE

Certificate No. UL-EU-01058-CPR
Page 142/144
Date of Issue 2017-10-27

Blank Seals – Single Batt Compress

Blank Seals installed in Rigid Floors as Identified below, protected by single compressed FB750 Intubatt seal, sealed with FS702 Intumastic or FS712 Intucoat.

Floor Details: Rigid floors of minimum thickness as identified below, and with performance classified to EN 13501-2.

Maximum Opening size: See below. Multiple openings must be separated by a minimum of 200mm for fire resistance requirements. Check separation requirements with the system owner of the supporting construction.

Installation Instructions: Single Layer board, compressed and bonded into the aperture flush with upper surface of floor. FB750 Intubatt should be installed in as few cut pieces as possible and tightly compressed to two opposite sides. This is achieved by the addition of 2mm to the required cut dimension. Compression may be applied - FB750 Intubatt to FB750 Intubatt or FB750 Intubatt to Substrate. Compression must be achieved over a minimum 60% of the FB750 Intubatt compressed edge. If compression is achieved between two opposite sides of FB750 Intubatt, perpendicular sides are not required to be compressed (the non-compressed seal should be fully abutted and bonded). All joints are to be bonded using FS712 Intucoat to full width of the FB750 Intubatt or FS702 Intumastic applied as a 10mm bead along the full-length joint centre line. FS702 Intumastic should be used to point all service and substrate interfaces, to a minimum of a 6mm bead. Imperfections should be filled with FS702 Intumastic to the full depth of the FB750 Intubatt. (Imperfections in cut on a compressed edge may not exceed 40% of the area available to receive compression)

The results below are also applicable when using multiple layers of compressed and bonded FB750 Intubatt within the floor, or single / multiple layers to the upper face of the floor.

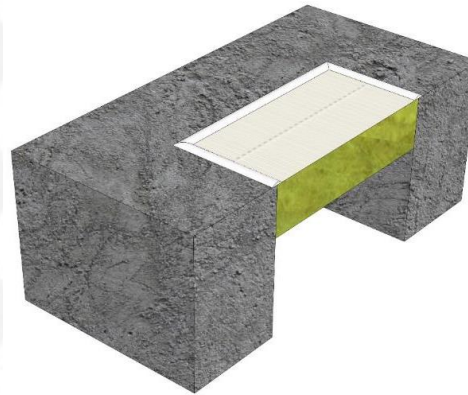

Form-ULID-006104 (DCS:27-CP-F0855) 5.0



Appendix UL-EU CERTIFICATE

Certificate No. UL-EU-01058-CPR
Page 143/144
Date of Issue 2017-10-27

Opening Size (mm)	Integrity	Integrity & Insulation	Rigid Floor Thickness (mm)	Additional Requirements
	E (mins)	EI (mins)	≥ 150	
≤ 450x400	120	120	✓	Opening framed with 95mm x 45mm European Redwood Cedar battens. Battens and FB750 Intubatt subsequently coated with 0.4mm DFT of Nullifire SC803 Intumescent Coating
≤ 500x500	120	60	✓	



Appendix UL-EU Certificate

Certification Mark	UL-EU mark
Certificate No.	UL-EU-01058-CPR
Page	144/144
Date of Issue	2017-10-27

The UL-EU Mark, as displayed below, shall appear on certified products only. Minimum size is not specified, as long as the Mark is legible. The following is suggested.



The minimum height of the registered trademark symbol ® shall be 1 mm. When the overall diameter of the UL-EU Mark is less than 9.5 mm, the trademark symbol may be omitted if it is not legible to the naked eye.

The UL-EU Mark may appear on a label, nameplate, or may be cast, stamped or molded into the product. When appearing on a label or nameplate, the Manufacturer's name or trademark along with a model number are also required on that same label or nameplate. If cast, stamped or molded, the Manufacturer's name or trademark and model number shall also appear elsewhere on the product.

All content shall be in accordance with the details provided on this UL-EU Certificate.

PROCUREMENT

The Production site may reproduce the Mark or obtain it from a UL authorized supplier. The list of UL authorized suppliers can be found on UL's online directory at www.ul.com.

Form-ULID-006104 (DCS:27-CP-F0855) 5.0

