

CI/SfB	(29)	(K2)
CAW P10		
Uniclass JP10:L68114		

Product Information

Description

FJ260 Cavity Barrier is a close state cavity barrier made of rock mineral wool and designed to maintain the required fire resistance around windows, doors and when following fire compartment lines.

Usage / Purpose

FJ260 Cavity Barrier is used as a cavity barrier, within external wall cavities in all required locations plus at the junction of compartment floors, compartment/party walls and around openings. It maintains fire resistance performance of cavities of up to 600 mm and only requires 5 mm of compression when fitting.

Colour

Light yellow, natural unfaced mineral wool.

Packaging

Supplied as slab of 1003 x 605 x 102 mm and can be cut to size to suit the cavity width.

Availability

Direct from Tremco CPG UK Limited (see details on this TDS).

Usage Guidelines

Always read SDS, pre-application guidance and relevant application detail prior to application. Ensure the latest documents are downloaded prior to every project commencement.

Necessary Tools

- Masonry drill
- Screwdriver
- Saw/knife for cutting product
- Measuring tape
- Stainless steel fixings suited to the substrate

Preparation

- Ensure the installation area is free from dust, oil and any corrosive material.
- Check the mounting substrate is solid and free from damage and degradation before beginning.

Brackets Fixing

FJ260 is supplied with 2 fixing spikes where required, FO306 Small Steel Brackets, dependent on requirement – please see Brackets Fixings table on the next page.

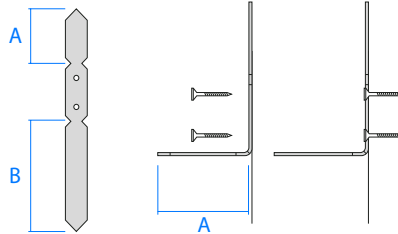

The central section is pre-drilled to secure the bracket to the substrate. Option A will protrude 65 mm or Option B will protrude 160 mm from the face of the substrate. If the bracket protrusion is greater than 75% of the product width, the bracket shall be cut down in length. The bracket should never be less than 50% of the product width.

Application

FJ260 Cavity Barrier from 15 mm up to 80 mm wide - directly faced fixed

1. Use stainless steel countersunk head screws, with a maximum head diameter of 11.5 mm and with a length suitable for the cavity barrier and the substrate.
2. Ensure that the countersunk screw head does fully penetrate the face of the cavity barrier, the screw head should sit at least 5 mm behind the face of the cavity barrier. Care should be taken not to compress the surface more than 10mm as this may compromise the performance of the cavity barrier.
3. Position the first screw fixing through the centre line of the face of the cavity barrier at a maximum 125 mm from one end, continue to face fix through at maximum 250 mm centres (4 screws per linear meter), ensuring that the final fixing is a maximum 125 mm from the end of the cavity barrier. This will ensure that face fixings are positioned at 250 mm centres across the continuous run of cavity barrier.

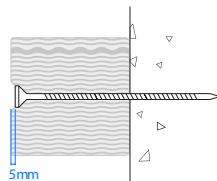

FJ260

Cavity Barrier

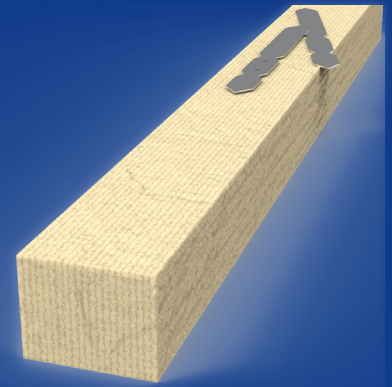

Key Benefits Summary

- Up to 2 hours fire resistance tested to EN 1366-4 (up to EI 120)
- Reaction to Fire class A1 (unfaced)
- Suitable for cavities up to 600 mm
- Easy to install
- Tested including SFS Systems with calcium silicate or cement particle boards
- Suitable for use vertically and horizontally
- No maintenance required after installation



FJ260 Cavity Barrier

Nullifire

Smart Protection

Bracket Fixings

Cavity Size (mm)	Product Width (mm) with 5 mm compression	Barrier Support Type	No. of Bracket Fixings per Metre	Maximum Bracket Centres (mm)	Face Fixed Fixing Centres (mm)
10 to 75	15- 80	Screw	N/A	N/A	250
76- 90	81- 95	FO306	2	500	N/A
91- 215	96- 220	FO306	2	500	N/A
216- 275	221- 280	FO306	3	350	N/A
276- 450	281- 455	FO306	2	500	N/A
200- 450 (Masonry Support Brackets)	205- 455	As required for cavity size	As required for cavity size	As required for cavity size	As required for cavity size

Fixing Locations

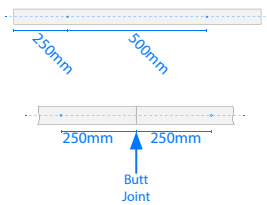

- Where sections of cavity barrier are less than 1 linear meter in length, ensure that face fixings are positioned at a maximum 250 mm from each end. For cut sections of cavity barrier less than or equal to 500 mm in length only one fixing is required.

FJ260 Cavity Barrier from 81 mm up to 95 mm - fixed using 2 Suitable Steel Brackets (FO306 for Stainless steel)

- Use a 5 mm Ø stainless steel screws, with a maximum head diameter of 13 mm and with a embedment suitable for the substrate. Ensuring the screw head sits as flush as possible with the substrate to enable the FJ260 to sit tight against the substrate leaving no gaps. Fix through both of the fixing holes.
- Fix 2 brackets, per linear meter, to the substrate at maximum 250 mm from the end of the cavity barrier, with a maximum spacing between brackets of 500 mm. Where sections of cavity barrier are less than 1 linear meter in length, ensure that FO306 required brackets are positioned at a maximum 250 mm from each end.

Fixing Locations

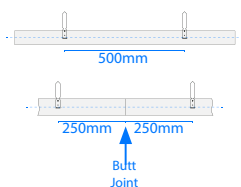

- Push the cavity barrier onto the bracket spike, the brackets should impale the FJ260 to mid barrier depth and should protrude into the barrier between 50% and 75% of the cavity width. The cavity barrier should be pushed fully onto the bracket spike and sit flush with the substrate, at the rear of the cavity barrier, ensuring that there are no gaps behind the cavity barrier.

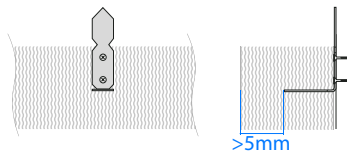

FJ260 Cavity Barrier from 96 mm up to 220 mm - fixed using 2 Suitable Steel Brackets (FO306 for Stainless steel)

- Use a 5 mm Ø stainless steel screws, with a maximum head diameter of 13 mm and with a embedment suitable for the substrate. Ensuring the screw head sits as flush as possible with the substrate to enable the FJ260 to sit tight against the substrate leaving no gaps. Fix through both of the fixing holes.
- Fix 2 brackets, per linear meter, to the substrate at maximum 250 mm from the end of the cavity barrier, with a maximum spacing between brackets of 500 mm. Where sections of cavity barrier are less than 1 linear meter in length, ensure that FO306 required brackets are positioned at a maximum 250 mm from each end.
- Push the cavity barrier onto the bracket spike, the brackets should impale the FJ260 to mid barrier height and should protrude into the barrier between 50% and 75% of the cavity width. The cavity barrier should be pushed fully onto

the bracket spike and sit flush with the substrate, at the rear of the cavity barrier, ensuring that there are no gaps behind the cavity barrier.

FJ260 Cavity Barrier from 221 mm up to 280 mm - fixed using 3 Suitable Steel Brackets (FO306 for Stainless steel)

- Use 3 brackets and a 5 mm Ø stainless steel screws, with a maximum head diameter of 13 mm and with a embedment suitable for the substrate. Ensuring the screw head sits as flush as possible with the substrate to enable the FJ260 to sit tight against the substrate leaving no gaps. Fix through both of the fixing holes.
- Fix 3 brackets, per linear meter. Bracket locations at 150 mm from each end of the cavity barrier with the final bracket being located on the centre line of the cavity barrier. Where the cavity barrier is less than 350 mm in length 2 brackets are required.

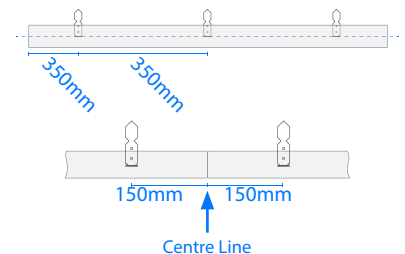

- Push the cavity barrier onto the bracket spike, the brackets should impale the FJ260 to mid barrier height and should protrude into the barrier between 50% and 75% of the cavity width. The cavity barrier should be pushed fully onto the bracket spike and sit flush with the substrate, at the rear of the cavity barrier, ensuring that there are no gaps behind the cavity barrier.



FJ260 Cavity Barrier

Nullifire

Smart Protection

FJ260 Cavity Barrier from 281 mm up to 455 mm wide fixed using 2 Brackets (FO306 for Stainless steel)

1. Use a 6 mm Ø stainless steel screws, with a maximum head diameter of 13 mm and with an embedment suitable for the substrate. Ensuring the screw head sits as flush as possible with the substrate to enable the FJ260 to sit tight against the substrate leaving no gaps. Fix through both of the fixing holes.
2. Fix 2 brackets, per linear meter, to the substrate at maximum 250 mm from the end of the cavity barrier, with a maximum spacing between brackets of 500 mm. Where sections of cavity barrier are less than 1 linear meter in length, ensure that FO306 required brackets are positioned at a maximum 250 mm from each end.
3. Push the cavity barrier onto the bracket spike, the brackets should impale the FJ260 to mid barrier height and should protrude into the barrier between 50% and 75% of the cavity width. The cavity barrier should be pushed fully onto the bracket spike and sit flush with the substrate, at the rear of the cavity barrier, ensuring that there are no gaps behind the cavity barrier.

In the event of an obstacle

The following instructions should be applied to the requirements stated above in the event of a masonry support obstacle (Fig. below):

- Any cutting of the FJ260 on site to suit tolerances, shall be done accurately and kept to a minimum. Ensure that the minimum 5 mm extra for the compression is maintained.
- Ensure there is a minimum of 28 mm from the top of the masonry support bracket to the top of the floor slab/FJ260.
- Mark where the brackets meet the FJ260 and cut a notch into the FJ260. Making the notch as small as is practicable.
- Compress the FJ260 and push into the cavity, ensuring the top of the FJ260 sits flush with the top surface of the floor slab.
- When extending the length of the FJ260, ensure the adjacent lengths have their joints tightly abutted together and are aligned flush with each other to give the appearance of a continuous strip with no gaps.

Important Information

- Before placing an order please complete the **Nullifire Project Questionnaire** for suitable product recommendation and presentation to the principal designer for acceptance.
- The cavity barrier should not be penetrated by anything other than the mechanical fixings which are used to fix the cavity barrier to the building.
- The cavity barrier should be installed onto a flat surface, with no gaps behind the cavity barrier.
- FJ260 Cavity Barrier should be installed in a continuous run. Where this is not possible, details should be agreed with the project's principal designer and/or fire engineer.
- The product is tested without interruptions with the exception of masonry support brackets (see specific detail).

- The use of tape is not required over the joints between the lengths of FJ260.
- FJ260 must be installed following the installation methods described above. FJ260 must not be penetrated by any other mechanical or electrical services.
- Our technical support should be consulted in any instance where the principal designer is uncertain as to any issues which may impede the ability of the cavity barrier to perform as expected.

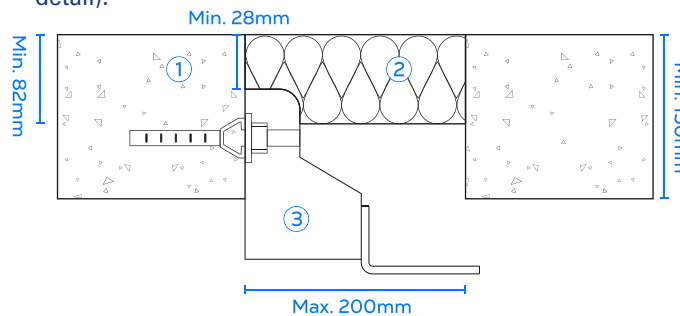

- ① 150mm thick lightweight concrete floor
- ② Nullifire FJ260
- ③ Masonry support system

- Horizontal cavity barriers should be installed adjacent and tightly abutted to any vertical cavity barriers, the vertical cavity barriers should be installed first. FJ260 Cavity Barrier may be cut to length as required, adjacent lengths must be tightly abutted together.
- Cavity barrier fixing brackets must not penetrate through the face of the cavity barrier. Screws for direct fixing and fixings to secure brackets are not supplied by CPG Europe.
- The brackets used to fix the FJ260 Cavity Barrier must be installed with the spike inserted centrally (horizontally) to the rock mineral wool.



FJ260

Cavity Barrier

Nullifire

Smart Protection

Considerations for the Principle Designer

- The principal designer must approve the use of any cavity barrier, whether open state or full fill, in conjunction with the products fire classification reports, taking full account of the whole construction of the external wall systems and components, including any requirements of Building Regulations and or NHBC Standards.
- The principal designer must sanction any interruptions, which may include items such as brackets, rails or battens, that may affect the continuous line of the cavity barrier. The principal designer must consider the combustibility, melting points and the shape of any interruptions, that are likely to prevent the cavity barrier performing as tested or as expected in the projects design.
- If there are interruptions/obstructions that prevent the cavity barrier being fitted in a continuous line, and with sanction from the principal designer, the product may be cut with a sharp knife and tightly butted up against any obstructions and then restarted on the opposite side of the obstruction, the obstruction must not create a void which is not filled.

Maintenance

No active maintenance required. Where alterations are made around the product it should be checked visually to ensure that the product is still installed as per the approved original design and fitting instructions at the time of original installation.

Health & Safety Precautions

Safety data sheet must be read and understood before use.

Technical Service

Tremco CPG UK Limited has a team of experienced Technical Sales Representatives who provide assistance in the selection and specification of products. For more information, service, advice please call Customer Services on 01942 251400.

Technical information

Property	Value
Reaction to Fire – EN 13501-1	A1
Composition	Compressed rock fibre
Available Density	110 kg/m ³
Water vapour permeability	MU1
Maximum Continuous Operating Temperature	500°C (plain)
Service Temperature	-20°C to +70°C
Storage	Store in dry, ambient conditions between -20°C and +70°C
Shelf Life	Unlimited when stored as recommended

Guarantee / Warranty

Tremco CPG UK Limited products are manufactured to rigid standards of quality. Any product which has been applied (a) in accordance with Tremco CPG UK Limited written instructions and (b) in any application recommended by Tremco CPG UK Limited, but which is proved to be defective, will be replaced free of charge. No liability can be accepted for the information provided in this leaflet although it is published in good faith and believed to be correct.

Tremco CPG UK Limited reserves the right to alter product specifications without prior notice, in line with Company policy of continuous development and improvement.

It is a requirement of the installer to ensure suitability and compatibility of all elements before installation commences and that compliance can be achieved as required.