

CI/SfB	(29)	(K2)
CAW P10		
Uniclass JP10:L68114		

Product Information

Description

FV065 Small Ventilated Cavity Barrier Roll is a fire rated product designed to be used as a cavity barrier up to 65 mm cavity within external walls. The product is encapsulated in a polythene barrier and made from a flexible intumescent material allowing it to be provided in a roll format.

Usage / Purpose

FV065 is used within external wall cavity, to reinstate fire resistance performance, of ventilated cavities, for up to 60 minutes for cavity widths of up to 65 mm, in fire conditions.

The product will act as an external wall cavity barrier at the required locations such as compartment floors, around windows, doors, etc. and within uninsulated cavities requiring permanent (open-state) ventilation.

In the event of a fire FV065's intumescent material will expand to close the external wall cavity, providing effective fire resistance, for integrity and insulation for up to 60 minutes depending upon the construction of the external walls. FV065 is designed to close off a total cavity of 65 mm which allows for building tolerances of up to 15 mm (above the typical maximum cavity ventilation requirements of 50 mm).

Product Dimensions

Length: 6300 mm

Height: 75 mm

Thickness: 6 mm

Colour

White

Packaging

PE Sleeve.

Box dimensions- 1,188 x 788 x 310 mm

Availability

Direct from Tremco CPG UK Limited (see details on this TDS).

Usage Guidelines

Always read SDS, pre-application guidance and relevant application detail prior to application. Ensure the latest documents are downloaded prior to every project commencement.

Necessary Tools

- Masonry drill
- Screwdriver
- Knife for cutting product
- Measuring tape
- Stainless steel fixings suited to the substrate

Preparation

- Ensure the installation area is free from dust, oil and any corrosive material.
- Check the mounting substrate is solid and free from damage and degradation before beginning.
- Double check for any obstructions, ensure that if there are any that could allow fire to pass vertically, they are fire stopped separately using an approved and applicable Fire Stopping product.

Fixings

Fixings (suitable screws or nails) must be fixed at maximum 40 mm from the end of the fire barrier and then at maximum 300 mm centres.

Screws - When fixing directly into substrates other than OSB is Staple Fixed, stainless

steel screws must be used. The diameter of the screw head should be a minimum of 5 mm and a maximum width of 11.5 mm, the length of the screw should be a minimum of 50 mm.

Nails - Nail guns may be used, however the firing pressure should be carefully controlled to ensure that the stainless steel nail does not push through the fire barrier. The nail head diameter must be a minimum 5 mm and maximum 11.5 mm, the nail should be a minimum of 50 mm long.

Pre Installation

Before FV065 is installed the following information is required to ensure that the selected product is approved for use in the actual construction being utilised.

- The type of construction being utilised, e.g. timber inner leaf and masonry outer leaf. Please note, FV065 is not suitable for use behind outer leaf designs of cladding, weatherboard and similar non-masonry/brickwork materials. Consult with our Technical Support for a suitable product for other outer leaf types.
- The required fire resisting performance of the cavity barrier, typically 30 minutes for integrity and 15 minutes for insulation (30/15 EI). Table B3 item 17 of Approved Documents (Fire Safety)

Nullifire
Smart Protection

FV065

Small Ventilated Cavity Barrier Roll



Key Benefits Summary

- Suitable for masonry and brickwork external substrates
- Ventilated design – developed to allow maximum ventilation of uninsulated cavities reducing the need for cavity trays or weepholes
- Suitable for ventilated cavities up to 65 mm wide, including building tolerances of up to 15 mm
- Lightweight - easy & quick to install
- Provided in rolls of 6.3 m long offering space and labour savings
- Moisture resistance packaging
- No maintenance required after installation



FV065

Small Ventilated Cavity Barrier Roll

Nullifire
Smart Protection

B1+B2:2020 (England and Wales).

- The orientation of the cavity barrier, horizontal or vertical. For vertical applications, please consult our Technical Support for appropriate product.
- The cavity size and the building tolerances of the cavity. (For example 50 mm designed cavity and building tolerance 10-15 mm).
- Take account of any insulation within the cavity, if insulation is required within the cavity please seek additional advice from our Technical Support as FV065 is not suitable for this application.
- When the above information is obtained then this can be cross referenced with FV065 product approvals table to ensure that the product selection is correct. The product selected should be confirmed as being approved by the person responsible for design, for example architect and or fire engineer.

Installation

- Ensure that the polythene sleeve fully covers the free end of the roll, if the intumescent material is visible pull the polythene sleeve back to reveal the intumescent material and cut enough of the intumescent material away to allow at least 50 mm of the polythene to be folded back behind the face of the roll.
- Once in position, ensure that the end of the roll is tightly butted up to the correct construction detail, then apply the first fixing within 40 mm of the beginning of the roll on the centre line of the roll.
- Continue along the centre line of the roll applying fixings at maximum 300 mm centres (suitable screws/nails) or 150 mm centres.
- If a new roll is required to complete the required run follow first 2 bullet points ensuring that the two ends of the intumescent material within the polythene sleeve are closely butted together and then continue with bullet point 3.
- Once the end of the required run is within 500 mm of the finish point, carefully mark the position required for the intumescent material, trim the polythene sleeve 50 mm longer than

Technical information

Property	Value
Fire Resistance: TGD19	Up to 60 minutes (see performance table)
Composition	Flexible intumescent material roll
Free Expansion	30:1 Ratio
Durability	Type X intended for use in conditions exposed to weather (UV, rain, frost)
Maximum Continuous Operating Temperature	80°C
Smoke / Halogen Content	Low smoke / Zero halogen
Service Temperature	-20°C to +70°C
Storage	Store in dry, ambient conditions between -20°C and +70°C
Shelf Life	60 years

required, pull the sleeve back to uncover the intumescent material, double check the required barrier length and trim the intumescent as required, to form a tight fit against the construction detail. Pull the polythene sleeve back over the intumescent material and fold back the 50 mm overcut polythene sleeve, using weather resistant tape, to the rear of the barrier.

- Ensure the final fixing is within 40 mm of the end of the roll.

Typical Details

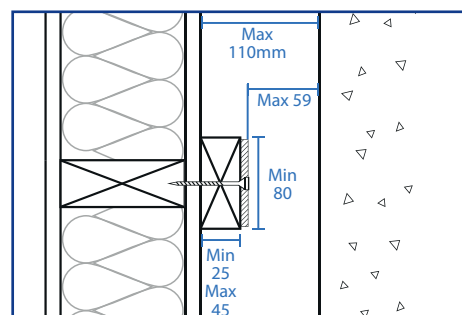
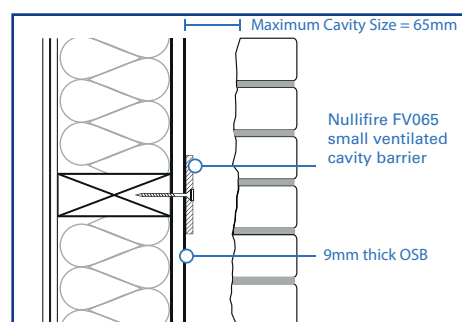

Important Information

- FV065 should freely face into the cavity and should be installed horizontally in a continuous band across the floor level of the building in line with the compartment floors.
- The correct positioning should be confirmed with the persons responsible for the design of the project.
- All joints must be tightly butted together so that the intumescent material is continuous throughout the cavity.
- Obstructions such as rails or timber battens should not interrupt, encase or cover FV065, battens and rails should be cut either side of the fire barrier.
- FV065 is not designed for use within cavities where insulation is required to be installed. More suitable alternatives are available from the Nullifire product range.
- Not approved for use behind cladding / weather-boarding.
- Approved for use behind masonry/ brickwork. (FV065 must be unobstructed to allow for free expansion).

Maintenance

No active maintenance required. Where alterations are made around the product it should be checked visually to ensure that the product is still installed as per the approved original design and fitting instructions at the time of original installation.



FV065

Small Ventilated Cavity Barrier Roll

Nullifire
Smart Protection

Health & Safety Precautions

Safety data sheet must be read and understood before use.

Technical Service

Tremco CPG UK Limited has a team of experienced Technical Sales Representatives who provide assistance in the selection and specification of products. For more information, service, advice please call Customer Services on 01942 251400.

Guarantee / Warranty

Tremco CPG UK Limited products are manufactured to rigid standards of quality. Any product which has been applied (a) in accordance with Tremco CPG UK Limited written instructions and (b) in any application recommended by Tremco CPG UK Limited, but which is proved to be defective, will be replaced free of charge. No liability can be accepted for the information provided in this leaflet although it is published in good faith and believed to be correct.

Tremco CPG UK Limited reserves the right to alter product specifications